

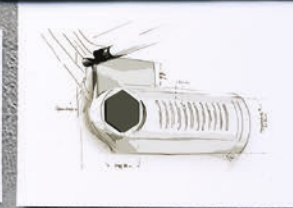

# One T for 1000 tasks

Strong and stable – the PPA Ultramid® Advanced T1000

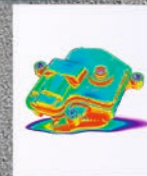
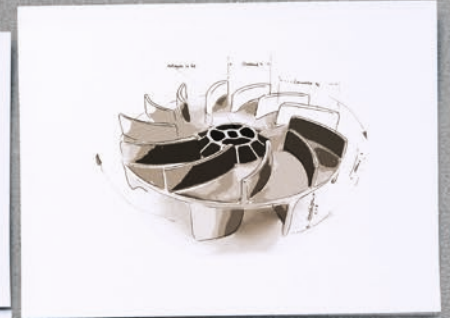
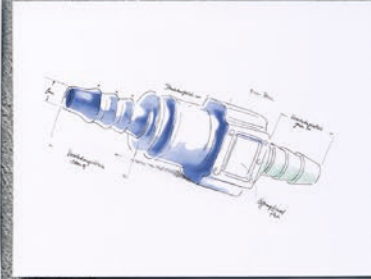
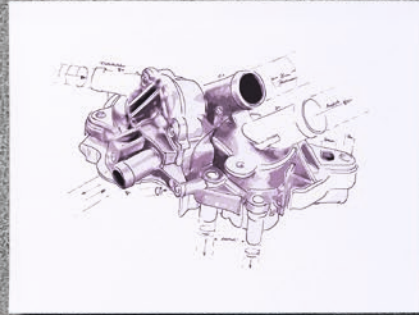

 **BASF**  
We create chemistry



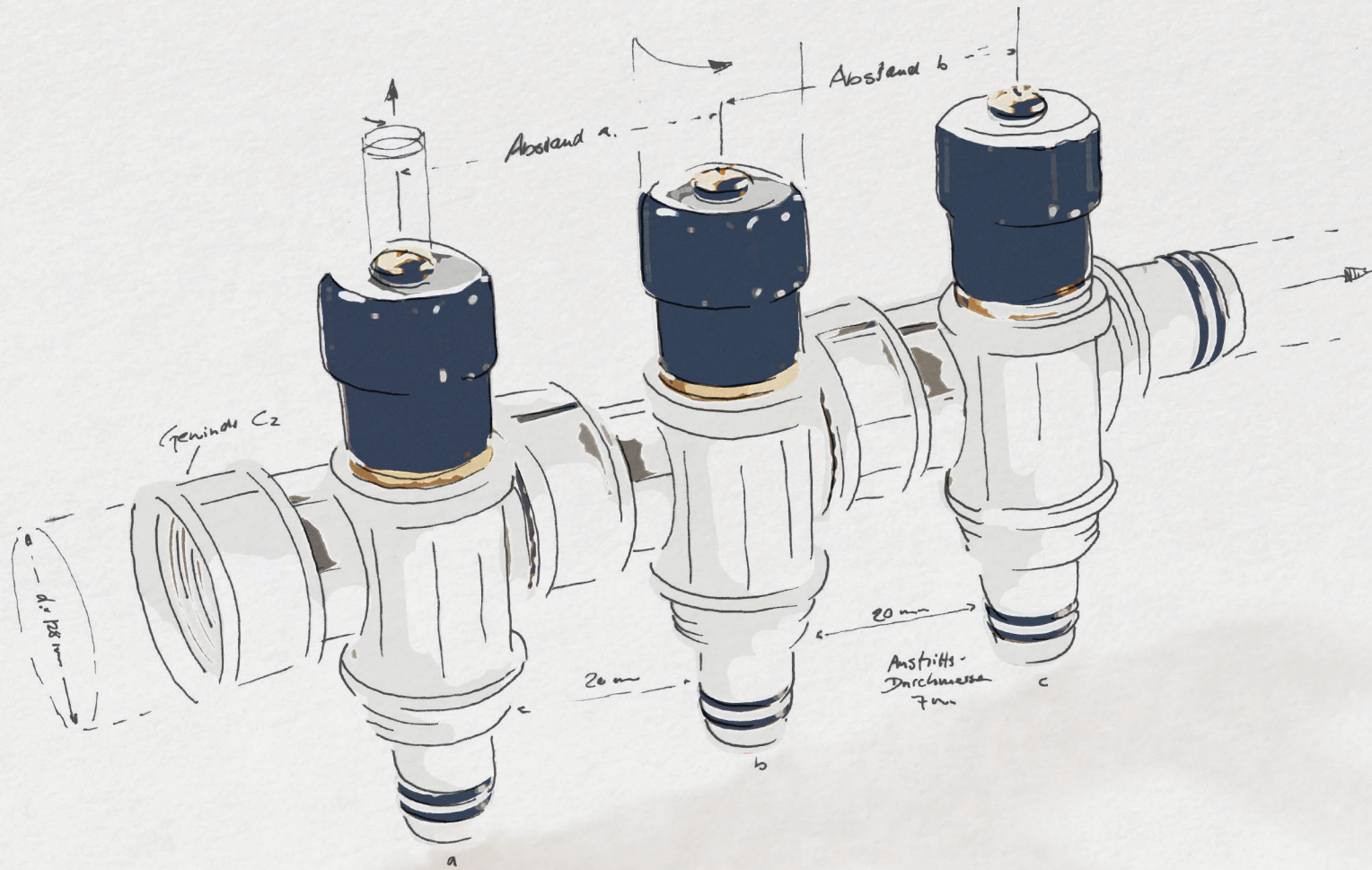

# Ultramid® Advanced T1000

## CONTENTS

THE PPA ULTRAMID® ADVANCED T1000 – ONE T FOR 1000 TASKS	4-5
KEY PROPERTIES	6-9
VERSATILE PORTFOLIO FOR DIFFERENT REQUIREMENTS	10-11
ULTRAMID® ADVANCED T1000 FOR THE AUTOMOTIVE AND TRANSPORTATION INDUSTRY	12-13
ULTRAMID® ADVANCED T1000 FOR CONSUMER, CONSTRUCTION AND INDUSTRIAL APPLICATIONS	14-15
EASY PROCESSING AND VERSATILE POST-PROCESSING	16-17
PRECISE PART DESIGN WITH ULTRASIM®	18

# The PPA Ultramid® Advanced T1000

## ONE T FOR 1000 TASKS

Metal replacement is the key for the development of the next generation of lightweight and high-performance parts in many industries. However, the challenges for parts made of conventional plastics have increased drastically by trends such as further miniaturization, higher efficiency targets and functional integration. In particular, good mechanical properties at high temperatures and resistance to humid environments or chemicals call for new plastic materials which are able to succeed under these demanding conditions.

Answering these trends, BASF is now extending its polyphthalamide (PPA) portfolio by Ultramid® Advanced T1000 – a new compound group based on the polyphthalamide 6T/6I. Ultramid® Advanced T1000 comprises the strongest and stiffest products of the Ultramid® (PA) family with stable mechanical properties up to temperatures of about 120 °C. Due to its partially aromatic chemical structure it offers high resistance against humidity and contact with challenging media – outperforming standard polyamides and many other PPA materials.

With this excellent property profile as well as BASF's long application experience and profound technical expertise, Ultramid® Advanced T1000 is a strong and stable material for many demanding applications – one T for 1000 tasks.

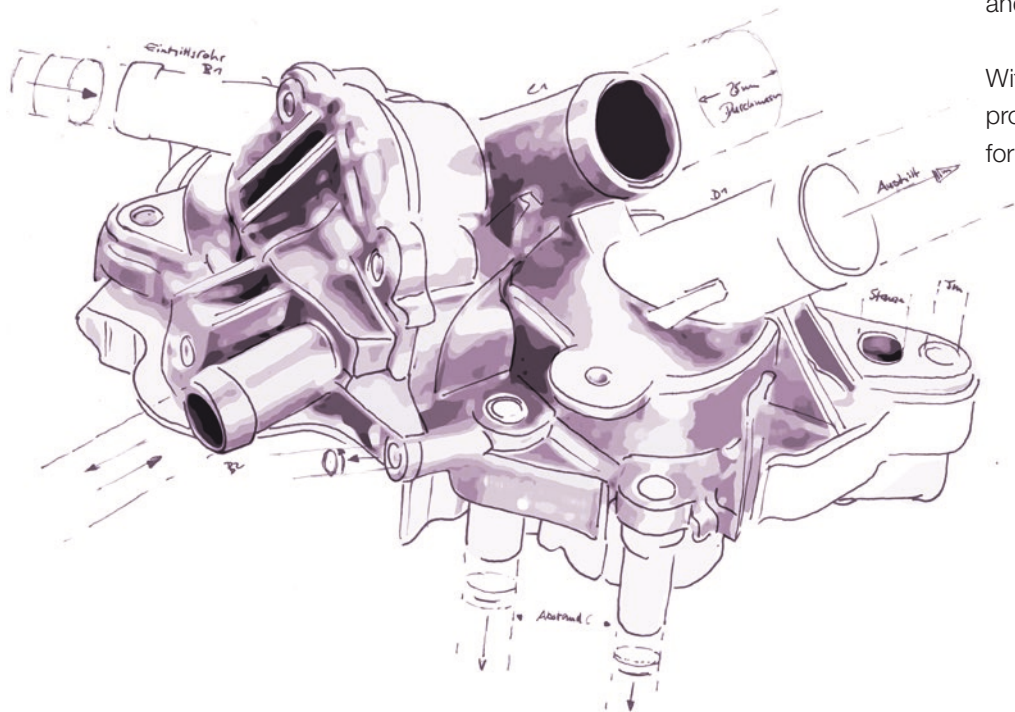

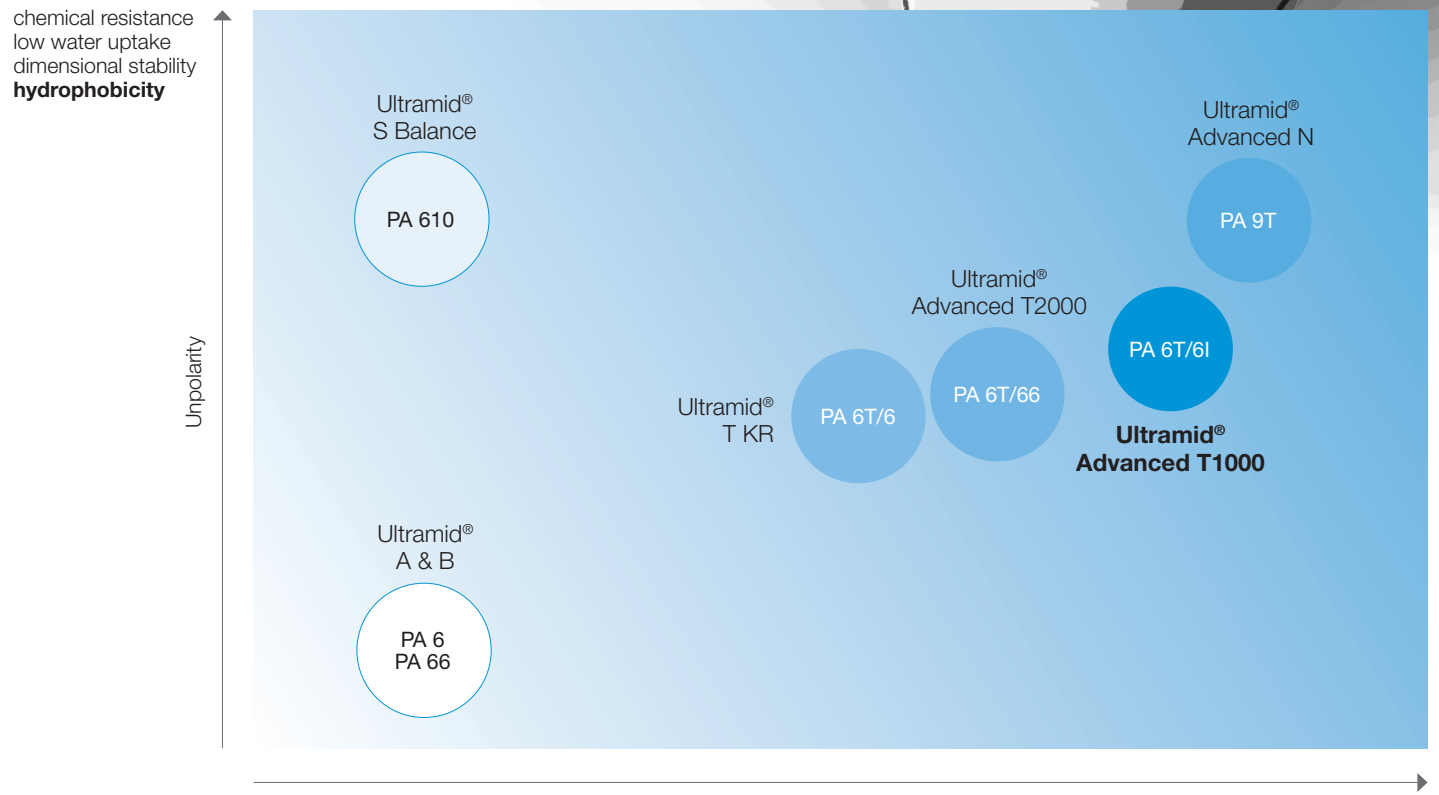
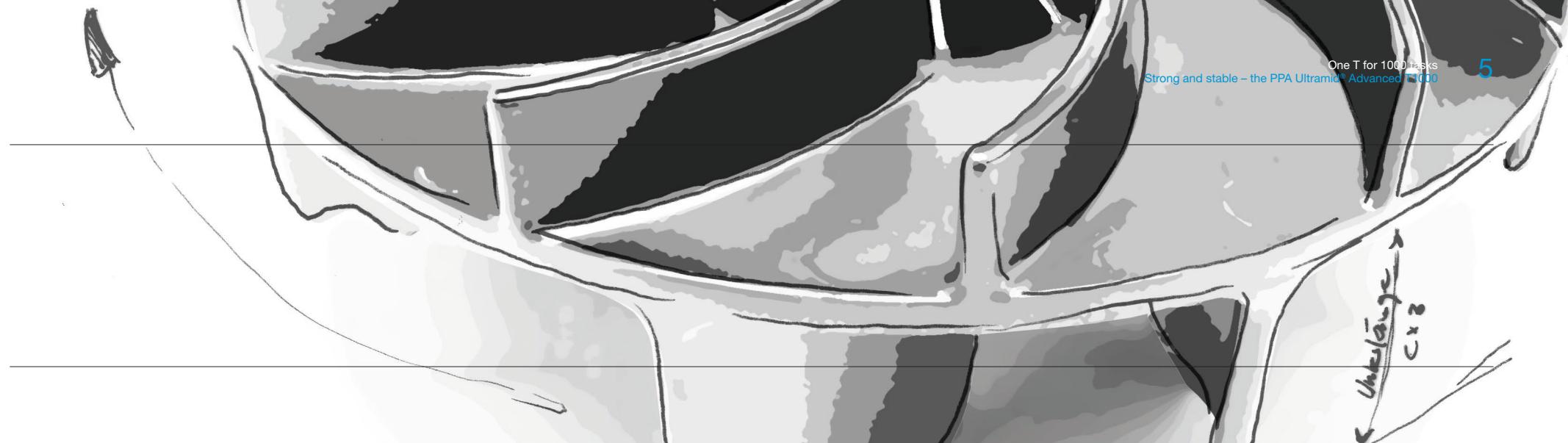

Fig. 1: Performance of different Ultramid® grades at elevated temperatures and in humid conditions

Conditioned glass transition temperature

# Ultramid® Advanced T1000

## KEY PROPERTIES

Ultramid® Advanced T1000 offers decisive advantages regarding mechanical properties, resistance to humidity and chemicals as well as for processing.

### Excellent mechanics:

- highest strength and stiffness of all Ultramid® grades and stable mechanical properties up to temperatures of about 120 °C (dry) and 80 °C in conditioned state (fig. 2)
- improved long-term mechanical performance under constant loads in presence of humidity and at elevated temperatures, e.g. as shown by creep test results at room temperature in conditioned state (fig. 3)

### Outstanding resistance to humidity and chemicals:

- higher chemical resistance compared to standard aliphatic polyamides in contact with many challenging media such as hot coolants, oils, aggressive fuels, and solutions of road salts containing calcium or zinc ions (fig. 4)
- lower water uptake than many aliphatic polyamides such as PA6 or PA66 resulting in high dimensional stability and small impact on properties (fig. 5)

### Efficient processing:

- simple processing by injection molding
- several post-processing options such as welding with other Ultramid® Advanced T1000 grades, polyamides or PPAs in general, and laser marking

For a broad application range, BASF developed several grades of Ultramid® Advanced T1000 with reinforcement levels ranging from 30 % up to 60 % glass fibers. Depending on the requirements of individual applications, different heat stabilizers as well as long glass fiber reinforced grades are available.

With these properties, Ultramid® Advanced T1000 can be applied in parts that require high and constant stiffness as well as strength over a temperature range from -40 °C to over 80 °C together with resistance to heat and challenging media.

Such applications can be found in:

- the transportation industry: in areas where materials have to remain strong in whatever temperatures or difficult climates
- all other industries where strength and resistance to humidity or chemicals are required.

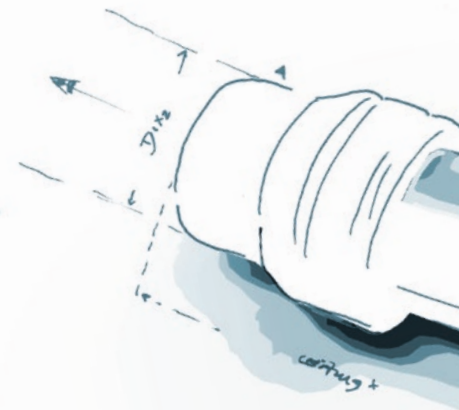

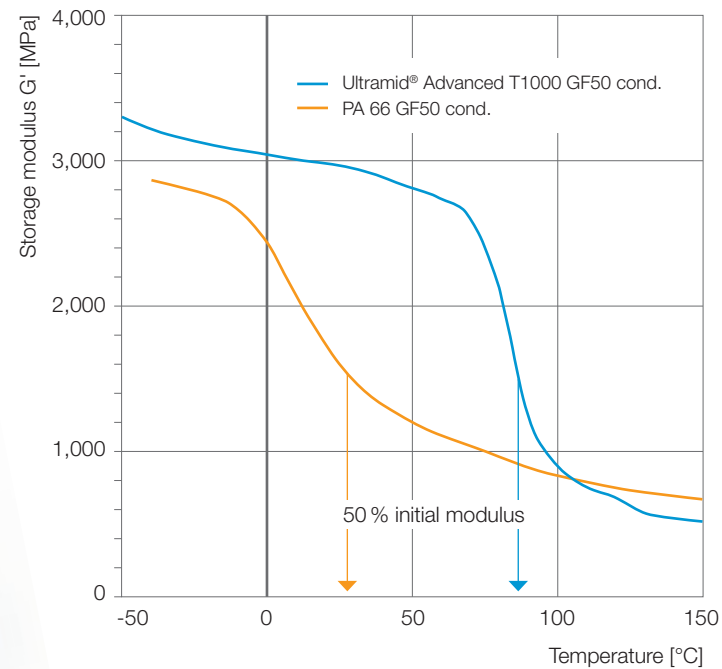
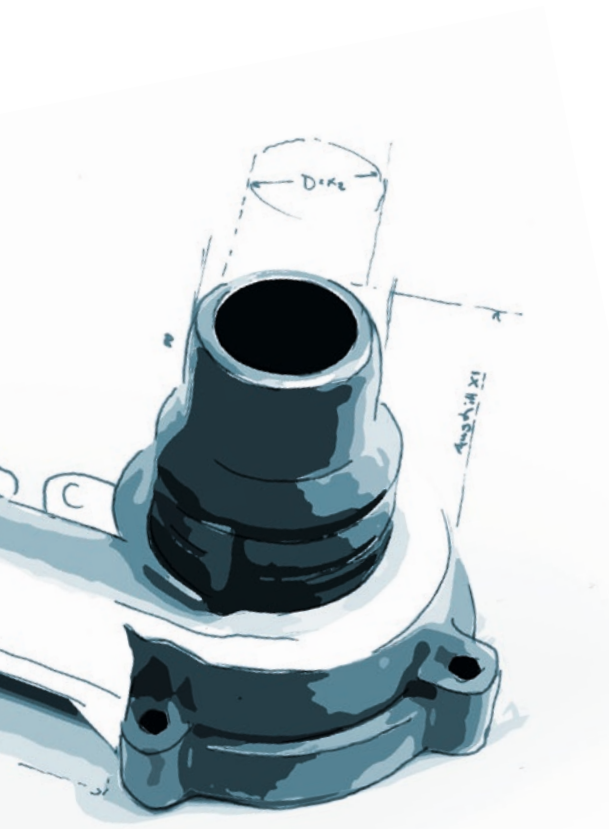

Fig. 2: Ultramid® Advanced T1000 with 50 % glass fiber reinforcement displays excellent mechanics with the highest strength and stiffness of all polyamides of the Ultramid® family, with stable mechanical properties up to temperatures of about 120 °C (dry) and 80 °C in conditioned state.

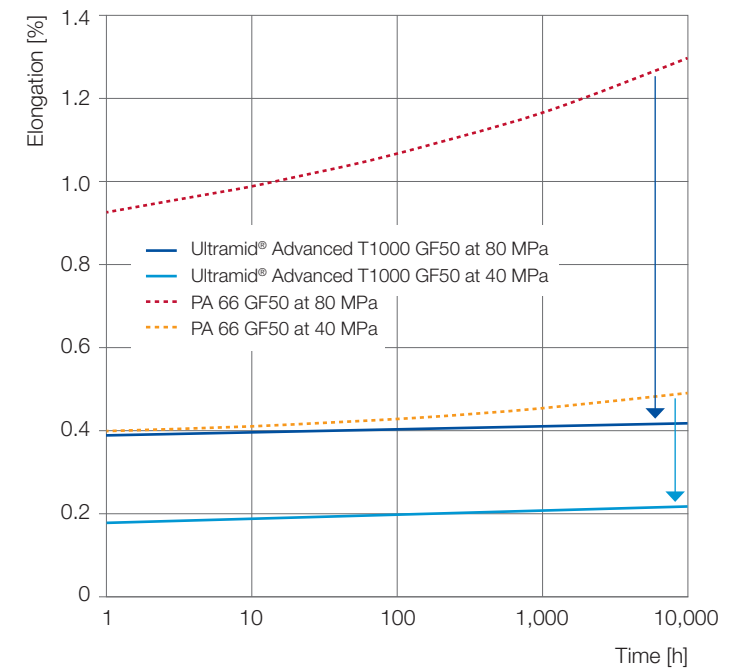

Fig. 3: Ultramid® Advanced T1000 with 50 % glass fiber reinforcement shows greatly improved long-term mechanical performance under constant loads at room temperature in presence of humidity (23 °C, 50 % r.h.). This advantage is even more pronounced at higher temperatures.

# Ultramid® Advanced T1000

## KEY PROPERTIES

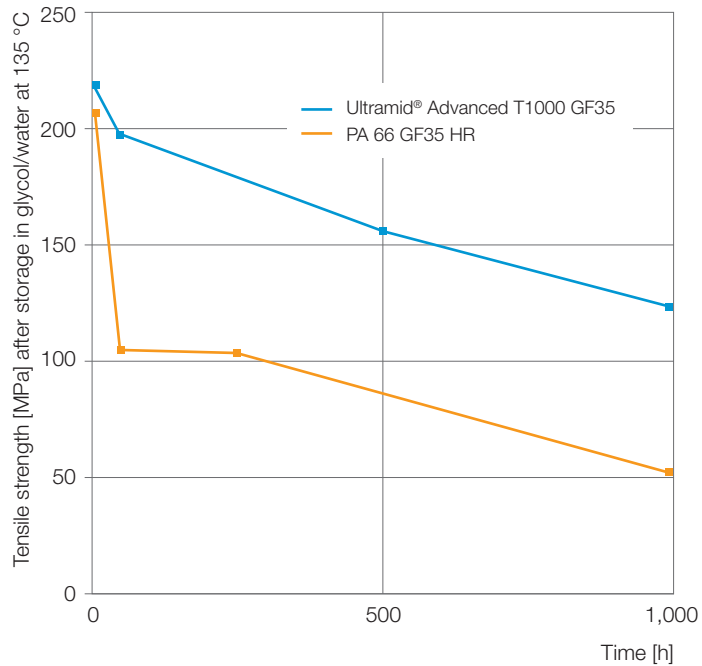

Fig. 4: Ultramid® Advanced T1000 with 35 % glass fiber reinforcement shows higher chemical resistance compared to standard aliphatic PA66 polyamides when tested in contact to coolants at 135 °C as well as excellent performance and retention of 50 % of initial strength for over 1,000 h.

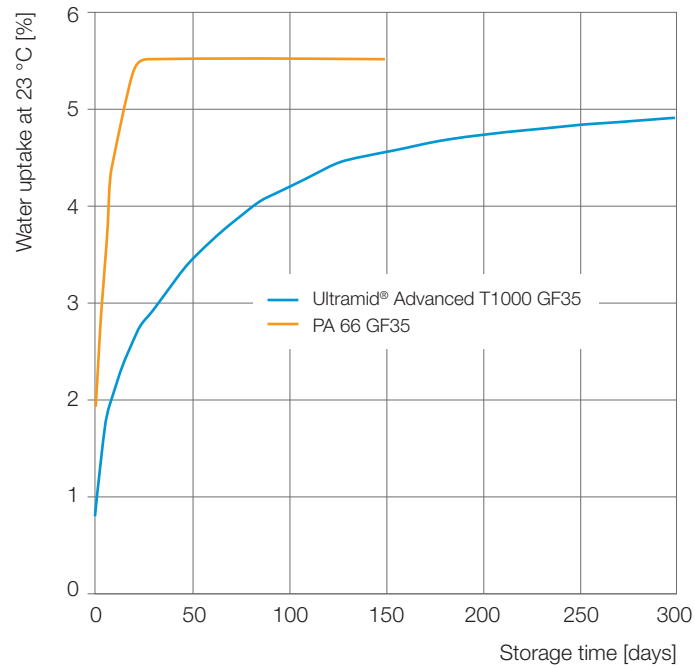

Fig. 5: Ultramid® Advanced T1000 with 35 % glass fiber reinforcement exhibits lower and slower water uptake than aliphatic PA66 polyamides (reinforced with 35 % glass fibers) resulting in high dimensional stability and small influence on mechanical and dielectric properties.



**Many of the general advantages of the Ultramid® product family are also typical properties of Ultramid® Advanced T1000:**

- good heat stability and resistance with retention of more than 50 % of the initial mechanical performance after storage at temperatures of 160 °C for much longer than 3,000 h, at 180 °C for about 3,000 h and at 200 °C for about 1,000 h (fig. 6)
- high retention of mechanical strength even at weld lines where glass fibers do not act as reinforcement. Ultramid® Advanced T1000 grades show weld line strength values of up to >100 MPa (fig. 7). Please note that weld lines are always to be considered when designing parts or molds and are ideally to be avoided in areas of high mechanical stress.

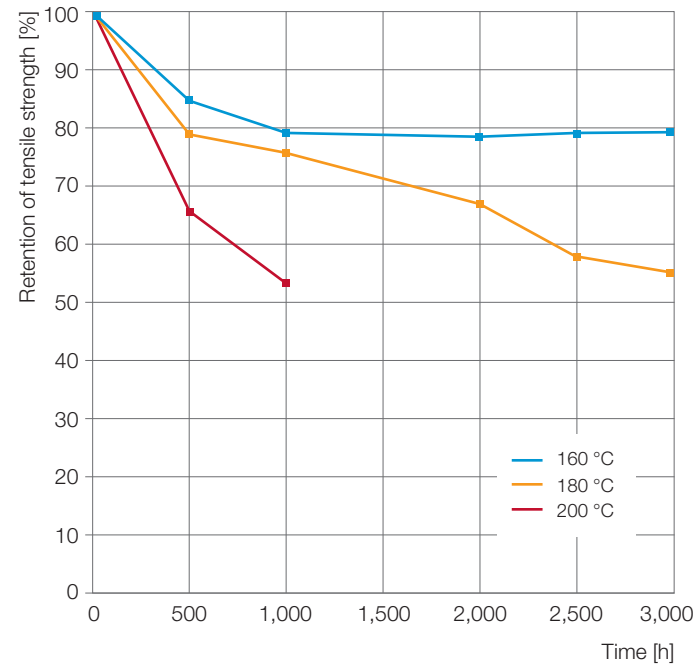

Fig. 6: Ultramid® Advanced T1000 with 50 % glass fiber reinforcement displays good heat stability and resistance with retention of initial tensile strength after heat storage at temperatures of 160 °C for much longer than 3,000h, at 180 °C for about 3,000 h and at 200 °C for about 1,000 h.

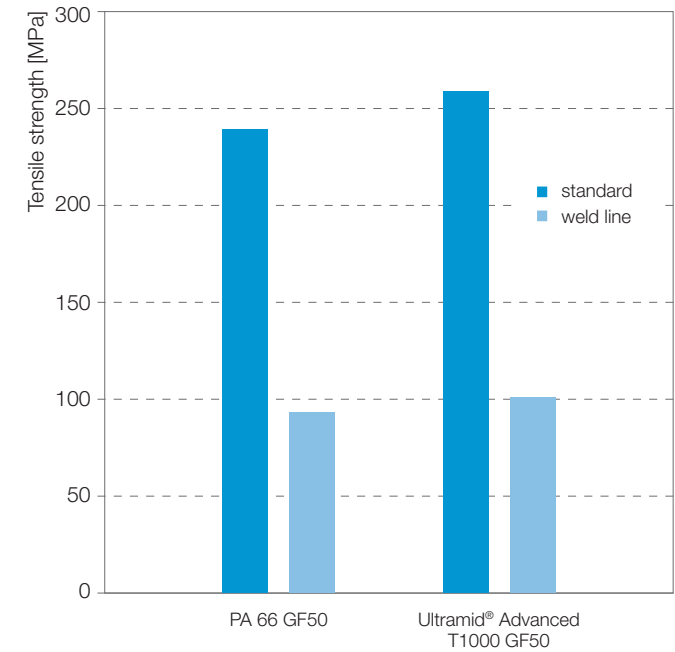
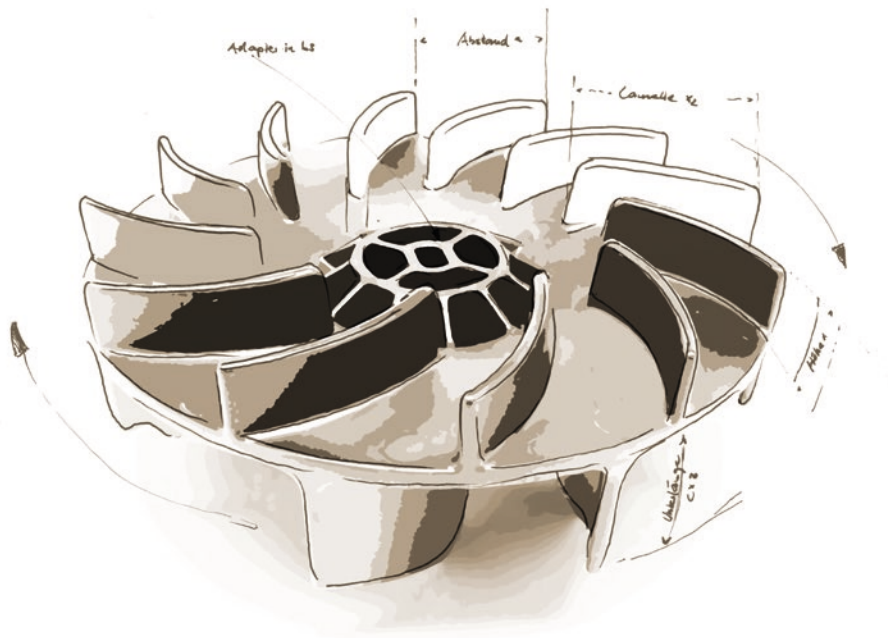

Fig. 7: Tensile strength values measured at room temperature on tensile bars with and without weld line for 50 % glass-fiber reinforced grades of PA66 and Ultramid® Advanced T1000. Ultramid® Advanced T1000 shows high retention of mechanical strength even at weld lines where glass fibers do not act as reinforcement.

# Ultramid® Advanced T1000

## VERSATILE PORTFOLIO FOR DIFFERENT REQUIREMENTS

BASF is launching Ultramid® Advanced T1000 as a portfolio consisting of different grades for many metal replacement requirements. The BASF product development and application specialists are dedicated to continuously developing this portfolio with further customized compounds to extend and improve the products' fit and performance according to customer demands.



### The initial portfolio consists of the following compounds:

- standard heat-stabilized, glass-fiber reinforced grades with reinforcement levels of 30 % to 60 % to provide a broad range of stiffness, strength and toughness
- special glass-fiber reinforced grades with improved hydrolysis resistance (HR) using 35 % or 45 % glass-fiber reinforcement
- a special long glass-fiber reinforced and high heat-stabilized compound (50 % LGF) for outstanding mechanical performance especially at higher temperatures

All grades are suitable for processing by injection molding.

Several other specialty grades are under development. Please contact our sales or technical team for a recommendation of the product that suits your specific application best.

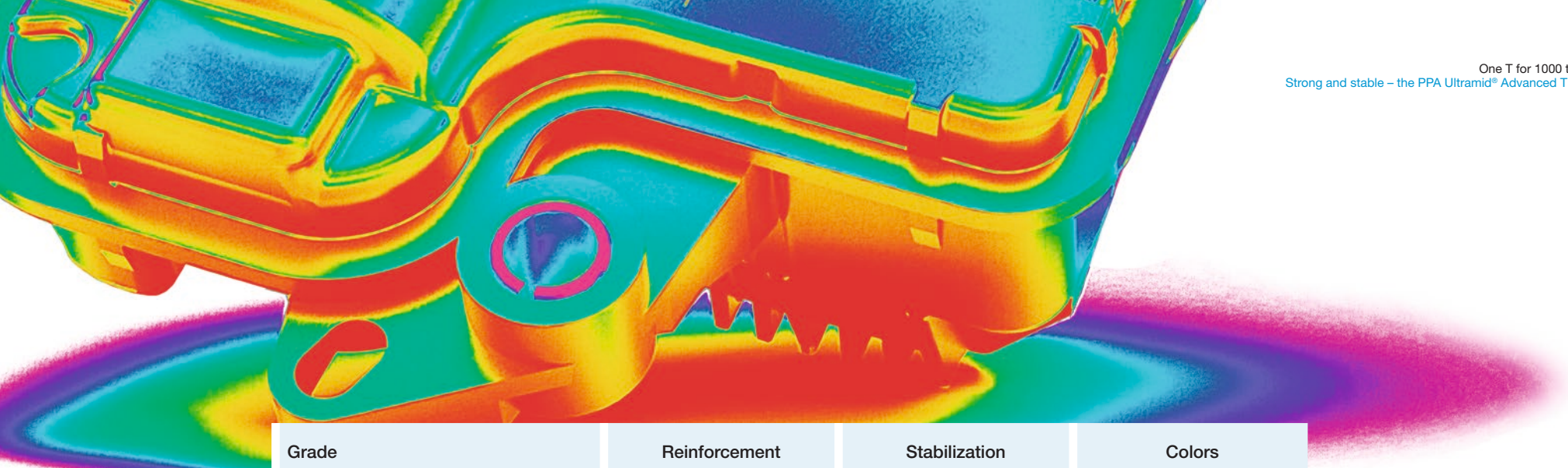

	Grade	Reinforcement	Stabilization	Colors
<b>Glass-fiber reinforced grades</b>	Ultramid® Advanced T1000 HG6	30 % GF	standard (H)	LS bk, un
	Ultramid® Advanced T1000 HG7	35 % GF	standard (H)	LS bk, un
	Ultramid® Advanced T1000 HG8	40 % GF	standard (H)	LS bk, un
	Ultramid® Advanced T1000 HG10	50 % GF	standard (H)	LS bk, un
	Ultramid® Advanced T1000 HG12	60 % GF	standard (H)	LS bk, un
<b>Special glass-fiber reinforced grades</b>	Ultramid® Advanced T1000 HG7 HR	35 % GF	standard	LS bk
	Ultramid® Advanced T1000 HG9 HR	45 % GF	standard	LS bk
	Ultramid® Advanced T1000 WG10 LFX	50 % LGF	high (W)	LS bk, un

# Ultramid® Advanced T1000

## FOR THE AUTOMOTIVE AND TRANSPORTATION INDUSTRY

Ultramid® Advanced T1000 is the strongest and stiffest polyamide in the Ultramid® family in the relevant temperature range of up to 80 °C in presence of moisture or water, thus outperforming standard aliphatic polyamides. Furthermore, due to excellent chemical resistance and retention of mechanical performance even under challenging hydrolytic conditions, Ultramid® Advanced T1000 retains its strength. The possible applications are numerous and diverse:

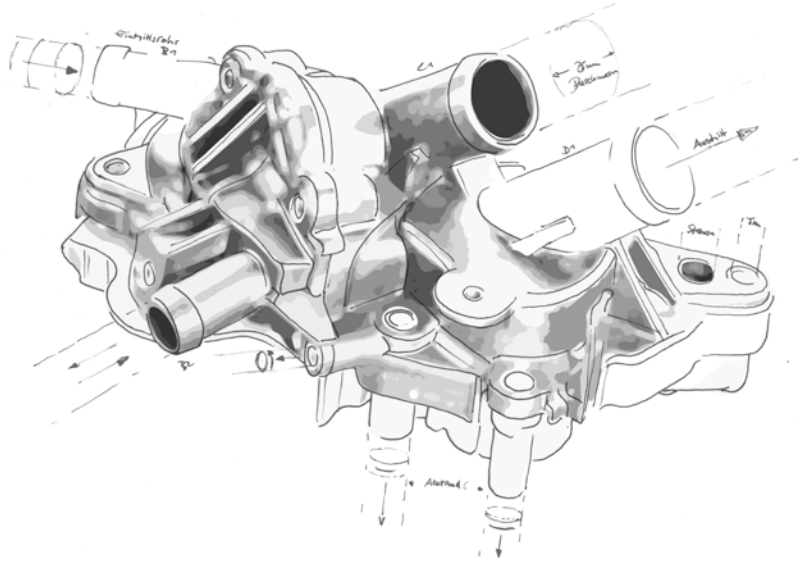

### Thermostat housing and water pump housing

Rising application temperatures can be challenging for standard engineering plastics such as PA6 or PA66 and even limit the lifetime of parts when in contact with hot coolants or other automotive fluids. Ultramid® Advanced T1000 provides excellent mechanical properties in presence of coolants at elevated temperatures and long-term media resistance. For example, more than 50 % of the tensile strength are maintained after storage in a 1:1 mixture of glycol (G48) and water at temperatures of 135 °C for more than 1,000 hours. Significantly longer resistance and mechanical performance are achieved at lower temperatures or in water only. With this high retention of strength and chemical resistance, higher long-term application temperatures and long part lifetimes are easily accessible with Ultramid® Advanced T1000.

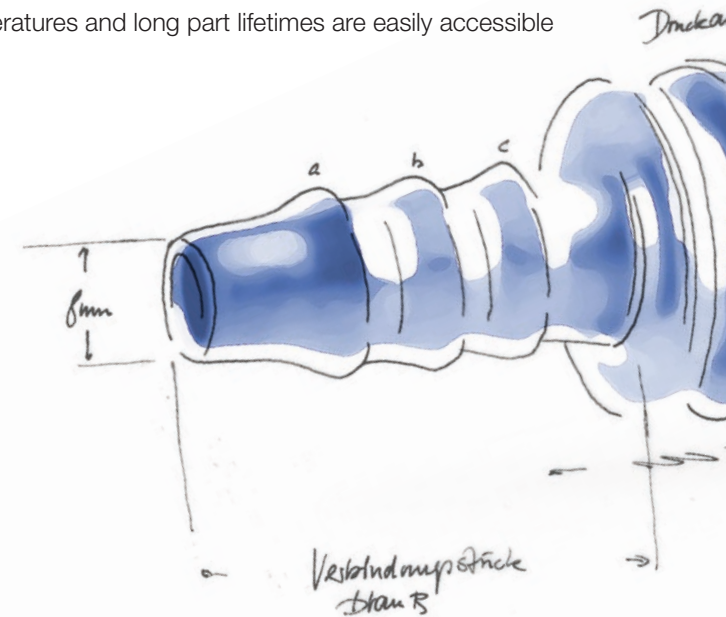

### Fuel system components (e.g. quick connectors, sensors)

Ultramid® Advanced T1000 shows higher resistance against challenging fuel components compared to standard aliphatic polyamide compounds, and long lifetimes even when fuels with high alcohol contents at elevated temperatures (e.g. E50, 90 °C) are used.

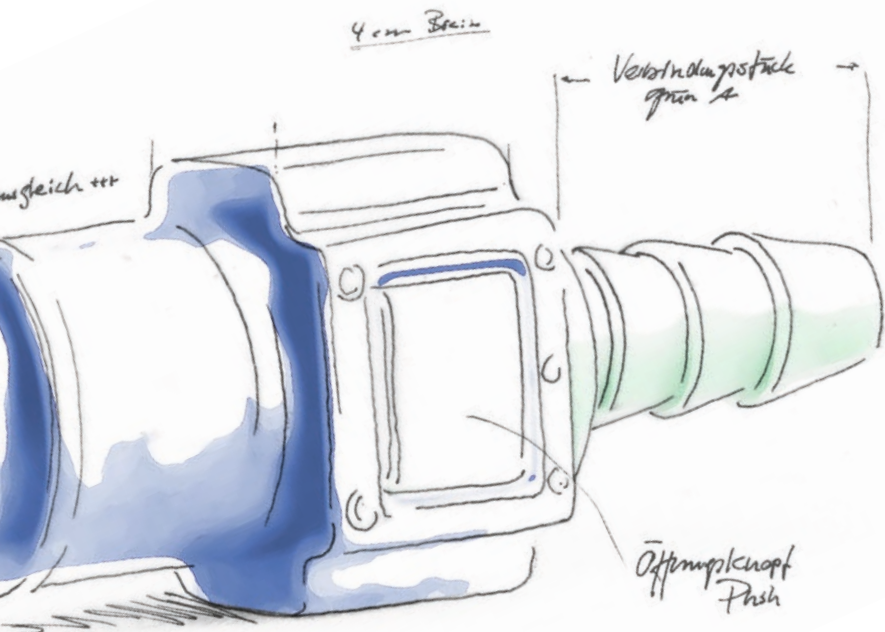

### Selective catalytic reduction (SCR) system components

(e.g. quick connectors, pumps)

Ultramid® Advanced T1000 has a high resistance against urea solutions also at elevated temperatures.

### Actuators and actuator housings (e.g. waste gates)

Ultramid® Advanced T1000 convinces with stable mechanical performance and dimensional stability over a broad temperature range, i.e. with especially high stiffness and strength at up to 120 °C.

### Clutch parts

Ultramid® Advanced T1000 shows the highest stiffness and strength of the Ultramid® product family at temperatures of up to 120 °C.

# Ultramid® Advanced T1000

## FOR CONSUMER, CONSTRUCTION AND INDUSTRIAL APPLICATIONS

Apart from transportation applications, Ultramid® Advanced T1000 has tremendous potential in other application areas where high mechanics at elevated temperatures and resistance to chemicals and hydrolysis are required, e.g. in consumer appliances, construction or industrial applications.

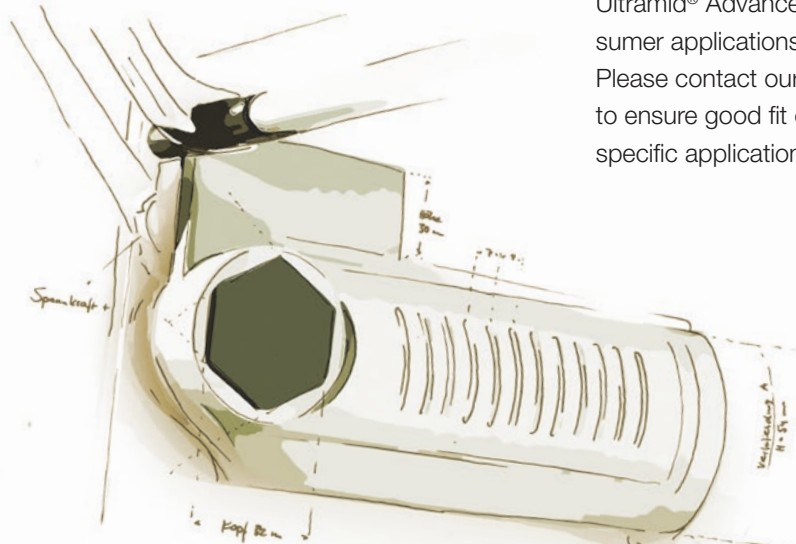

### Coffee machines (e.g. brewing unit)

Ultramid® Advanced T1000 has high stiffness and strength even when in contact with boiling water and shows excellent resistance to hydrolysis at the required application temperatures. Food contact approvals for Ultramid® Advanced T1000 grades to be used in consumer applications are under way.

Please contact our sales and technical team in advance to ensure good fit of the grades and approvals to your specific application.

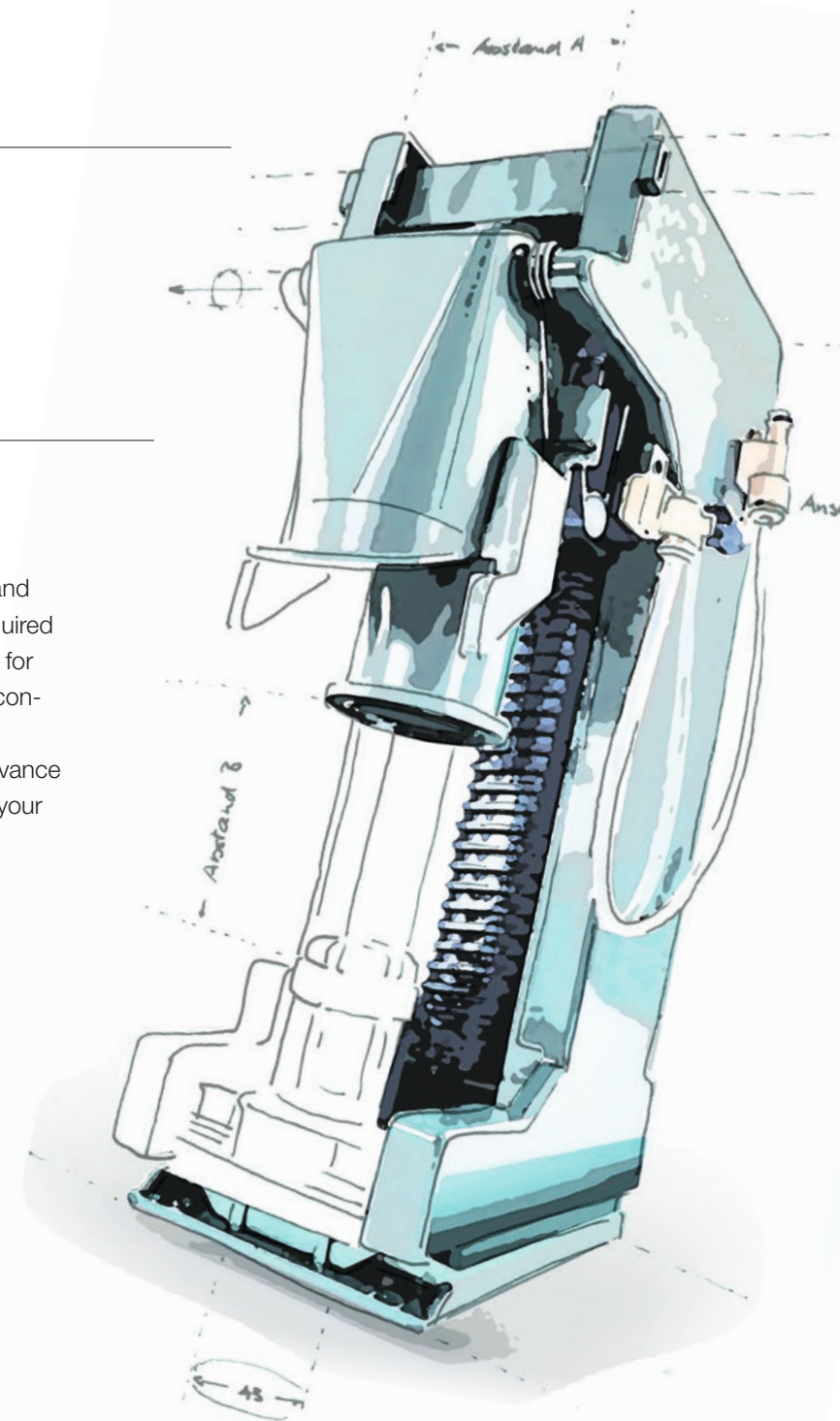

### Furniture fittings

Ultramid® Advanced T1000 exhibits high stiffness, strength and creep resistance – also in presence of moisture and humidity.

### Distributors and heating system parts

(distributor, flow meter and regulator)

Ultramid® Advanced T1000 is a great choice when parts need high stiffness, strength, creep and chemical resistance even when in permanent contact with water and at elevated temperatures.

### Pumps and pump parts

(e.g. impeller, housing, valves)

Ultramid® Advanced T1000 features high stiffness, strength and resistance against hydrolysis or oils at elevated temperatures.

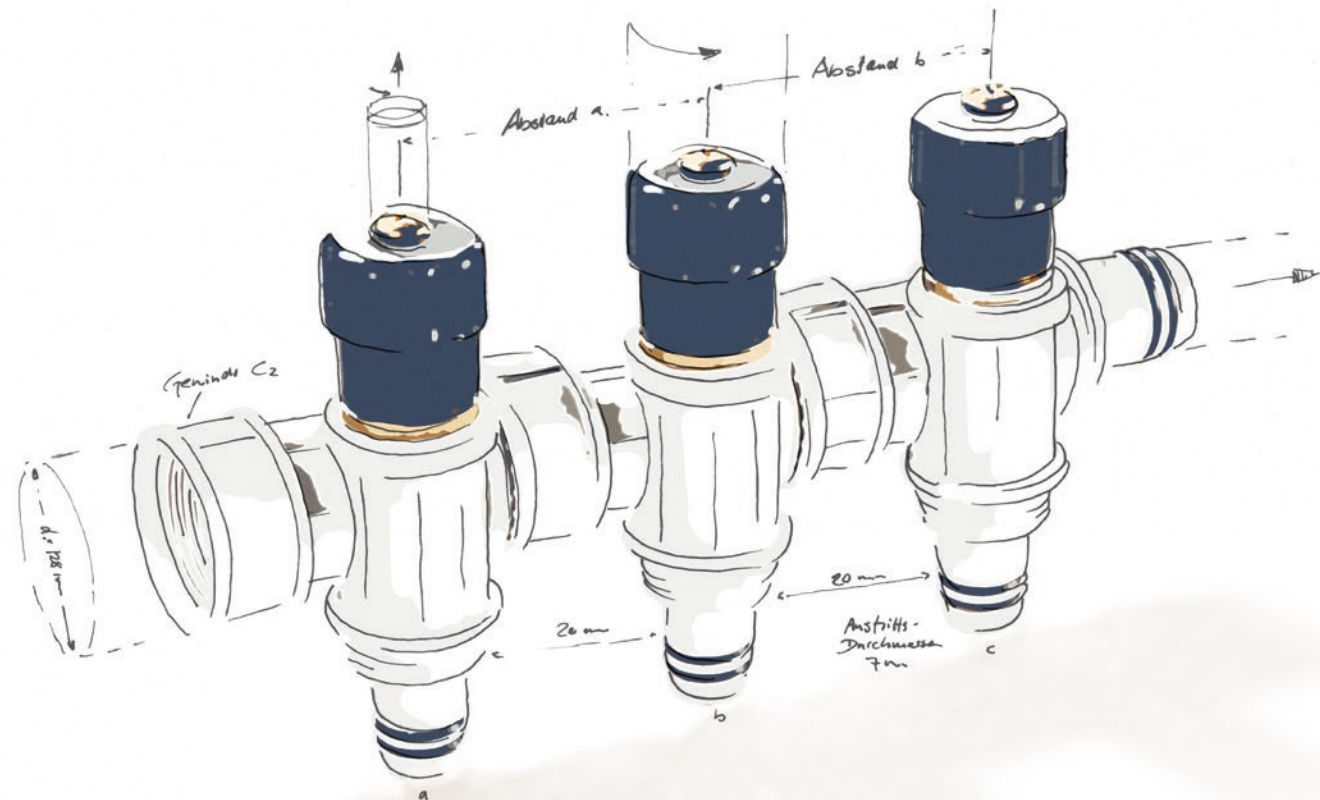

# Ultramid® Advanced T1000 – EASY PROCESSING

Ultramid® Advanced T1000 can be easily processed with standard injection molding machines. Being a material with a very high melting point of 320 °C as well as a high glass transition temperature, the optimum processing conditions need to be chosen accordingly: the melt temperature range should be between 330 °C and 350 °C, mold temperatures between 140 °C and 160 °C.

Ultramid® Advanced T1000 is not sensitive against changing processing conditions such as variations in dosing or injection speed. It can be processed with hot runner systems and needle valve nozzles.

The spectrum of flowabilities covered by the various Ultramid® Advanced T1000 grades are shown in figure 8. When processed at optimum conditions, the flow path lengths are similar to those of standard PA66 glass-fiber reinforced materials.

Detailed processing instructions are available to enable optimum injection molding conditions, also for individual grades. Please ask your sales or technical contact for further information.

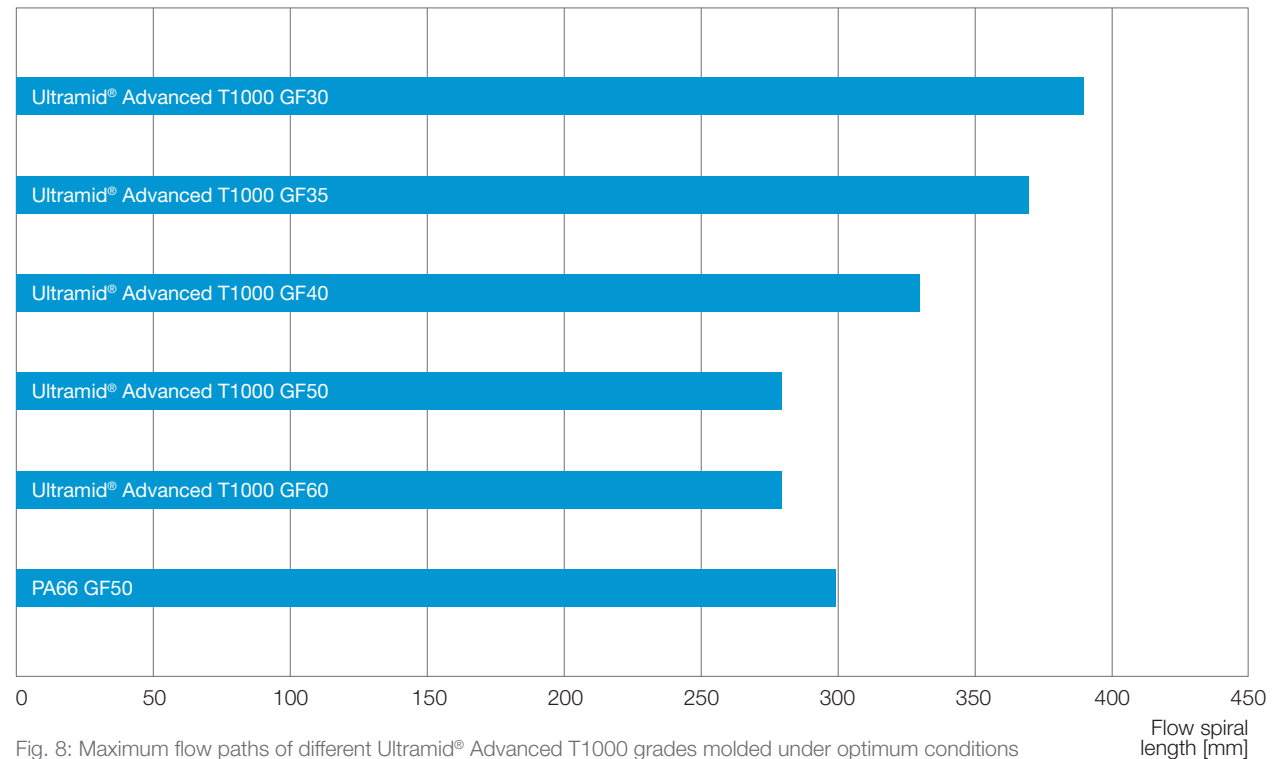

Fig. 8: Maximum flow paths of different Ultramid® Advanced T1000 grades molded under optimum conditions in comparison to PA66 (reinforced with 50 % glass fibers) for a flow spiral mold of 2 mm thickness. The different Ultramid® Advanced T1000 grades were processed at 345 °C melt temperature and 150 °C mold temperature with constant injection speed and injection pressure.



# Ultramid® Advanced T1000 – VERSATILE POST-PROCESSING

Plastic parts made of Ultramid® Advanced T1000 can be further processed using many different methods:

- They can be welded to complex structural elements using rotational, vibration or laser welding.
- Most grades are laser markable. Combined with a smooth surface, the markings feature high contrast (fig. 9).



Fig 9: With Ultramid® Advanced T1000, parts can be excellently laser-marked.

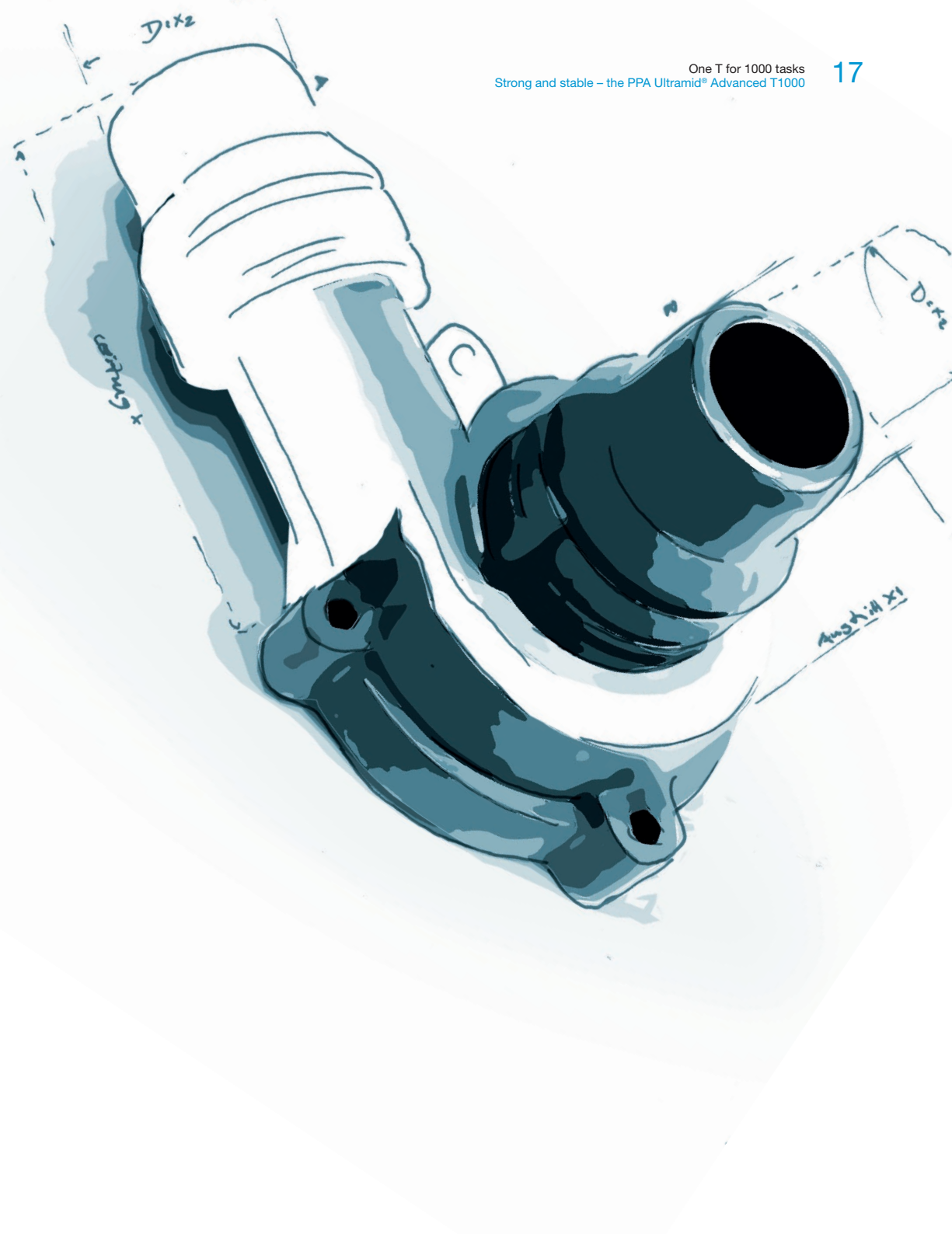

## Ultramid® Advanced T1000 – PRECISE PART DESIGN WITH ULTRASIM®

BASF's simulation tool Ultrasmim® is used in the design of parts for all industries. Examples are found in automotive and mechanical engineering, in construction, in power tools and household appliances, and in parts for the sports and leisure sectors.

With customized models, BASF has further developed the calculation tool in such a way that parts made of Ultramid® Advanced T1000 can also be simulated. Using Ultrasmim®, the physical behavior of the part can be predicted on the basis of manufacturing parameters, fiber anisotropy and load direction or speed. The mathematical part optimization can furthermore provide the best possible design under the given conditions.

Ultrasmim® is therefore a unique tool for optimizing customer parts at a very early stage so that they are able to handle highest loads. With these precise predictions, costs and time associated with prototypes or extensive mold corrections can be minimized.

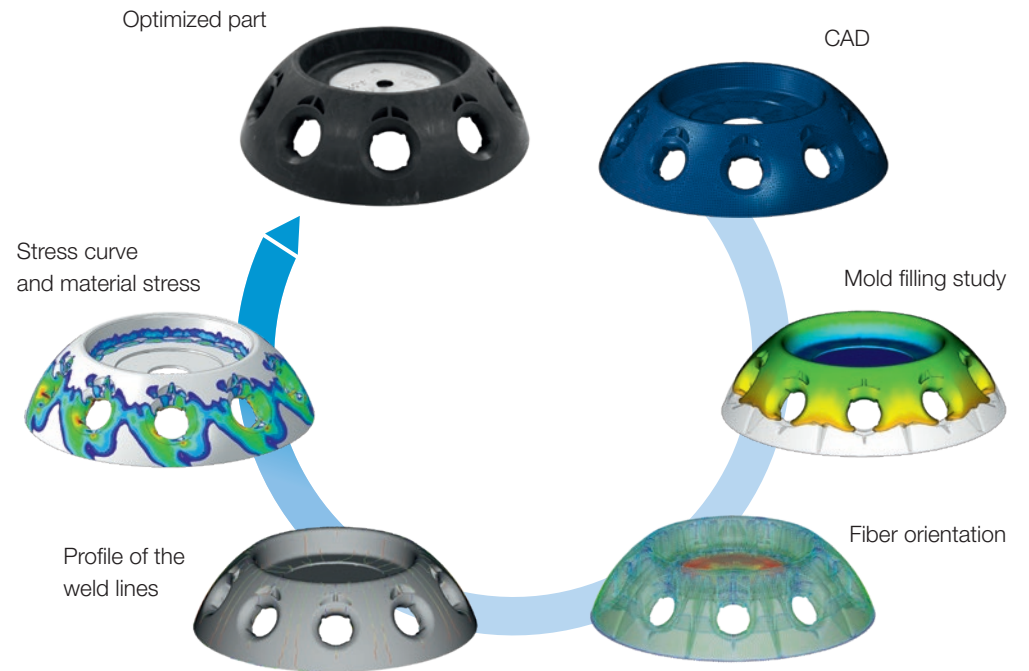
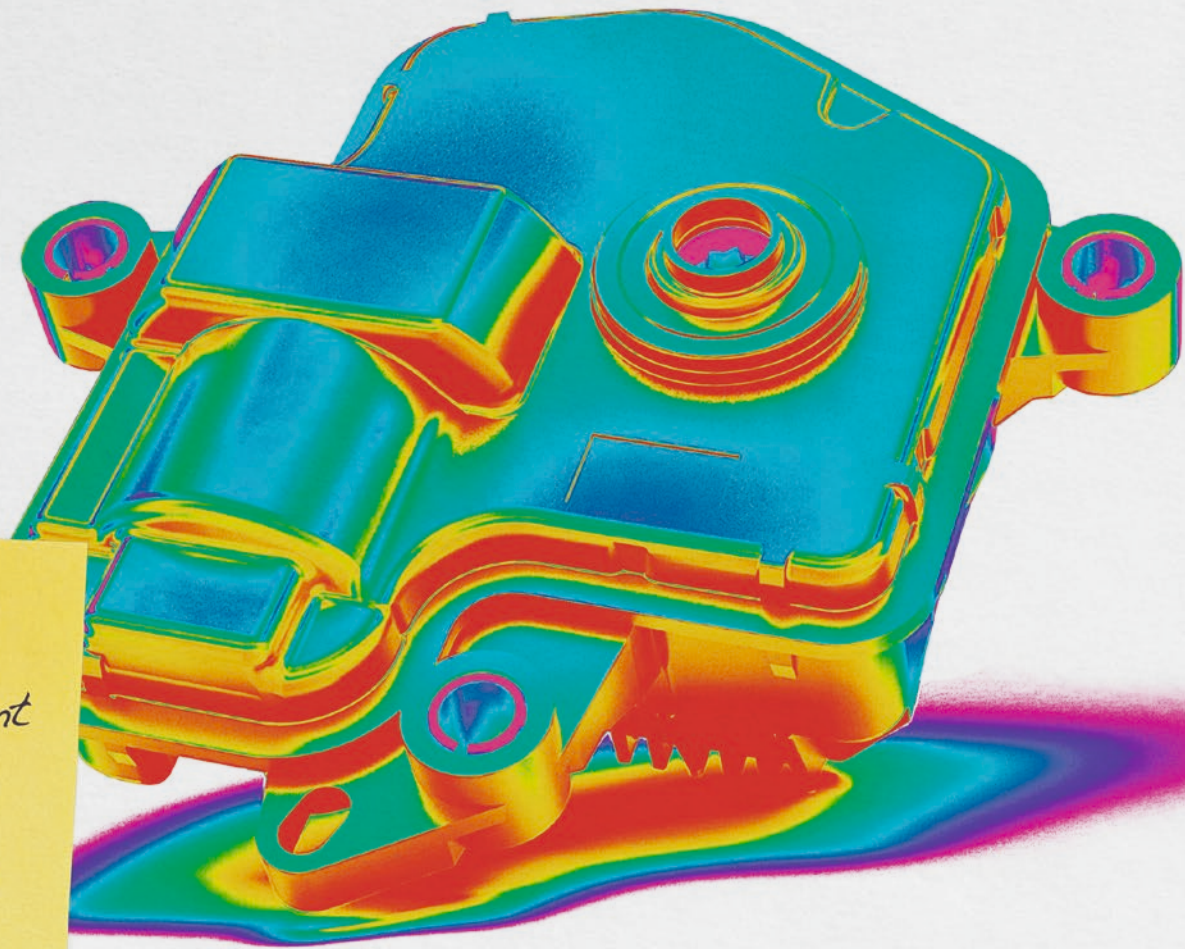

Fig. 10: Process of designing parts with the BASF simulation tool Ultrasmim®

**Contact us to  
find out more**  
about Ultramid®  
Advanced T1000 –  
our T for 1000 tasks.

*ultraplaste.infopoint  
@basf.com*

*+49 621 60-78780*



**Further information on Ultramid® Advanced T1000  
can be found on the internet:**

[www.ultramid-advanced-t1000.basf.com](http://www.ultramid-advanced-t1000.basf.com)

For more possibilities with BASF's PPAs, please refer to the brochures  
on Ultramid® Advanced N and Ultramid® Advanced T2000.

Or go to:

[www.ultramid-advanced-n.basf.com](http://www.ultramid-advanced-n.basf.com)

[www.ultramid-advanced-t2000.basf.com](http://www.ultramid-advanced-t2000.basf.com)



The right material for the right part: choose the suitable material for your application!  
**PPA Product Selector on [www.ppa.basf.com](http://www.ppa.basf.com)**

**Please also visit our websites:**

[www.plastics.basf.com](http://www.plastics.basf.com)

**Request of brochures:**

[plas.com@basf.com](mailto:plas.com@basf.com)

**If you have technical questions on the products,  
please contact the Ultra-Infopoint:**

**i Ultra  
Infopoint**  
+49 621 60-78780  
[ultraplaste.infopoint@basf.com](mailto:ultraplaste.infopoint@basf.com)

#### Note

The data contained in this publication are based on our current knowledge and experience. In view of the many factors that may affect processing and application of our product, these data do not relieve processors from carrying out own investigations and tests; neither do these data imply any guarantee of certain properties, nor the suitability of the product for a specific purpose. Any descriptions, drawings, photographs, data, proportions, weights etc. given herein may change without prior information and do not constitute the agreed contractual quality of the product. It is the responsibility of the recipient of our products to ensure that any proprietary rights and existing laws and legislation are observed. (April 2021)