

Ultramid® (PA)

Product Range
(Europe)

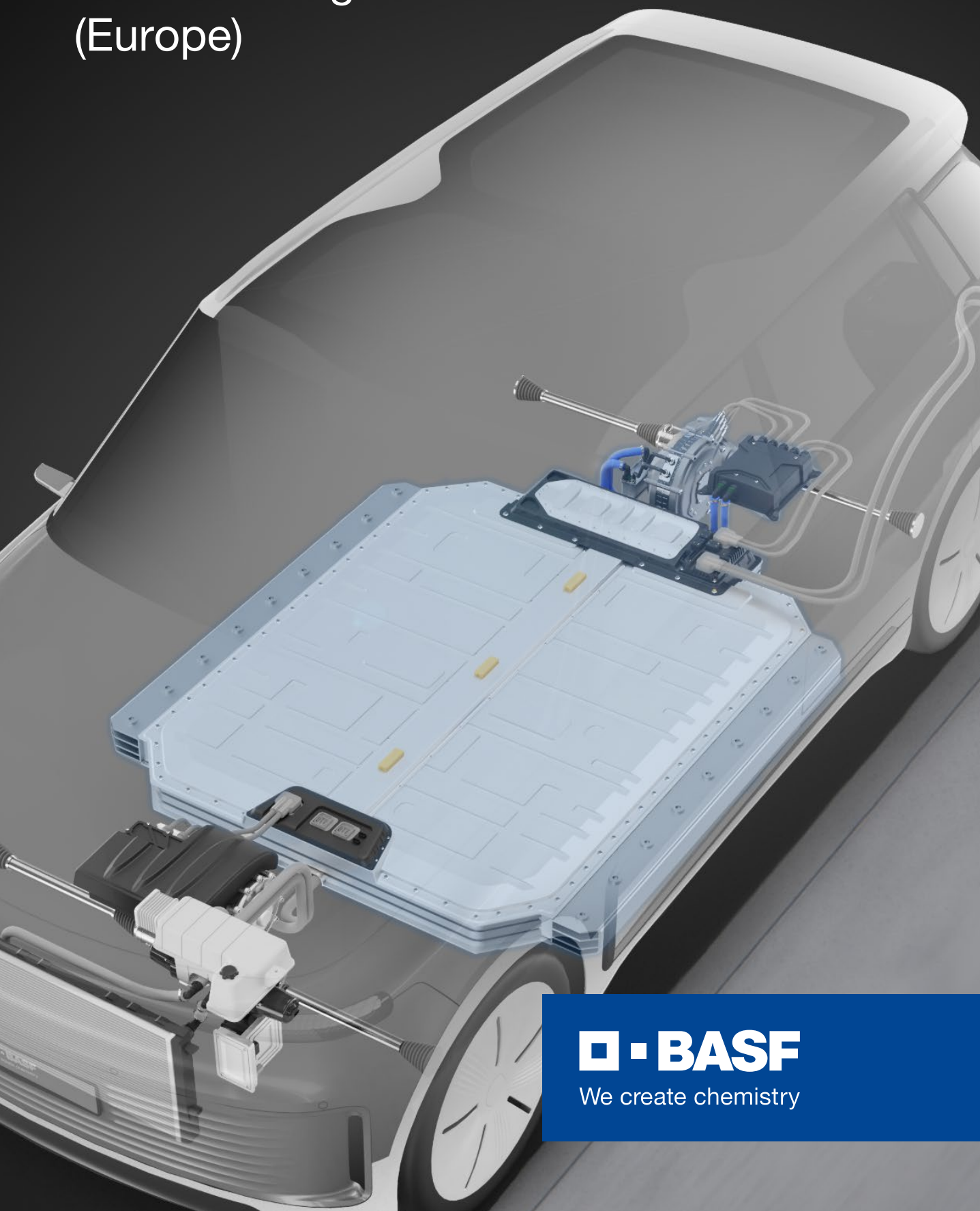

 **BASF**

We create chemistry

Ultramid® (PA)

BASF's Ultramid® grades are molding compounds on the basis of PA6, PA66 and various co-polyamides such as PA66/6. The range also includes PA610 and partially aromatic polyamides such as PA6T/6. The molding compounds are available unreinforced, reinforced with glass fibers or minerals and also reinforced with long-glass fibers for special applications. Ultramid® is noted for its high mechanical strength, stiffness and thermal stability. In addition, Ultramid® offers good toughness at low temperatures, favorable sliding friction behavior and can be processed without any problems. Owing to its excellent properties, this material has become indispensable in almost all sectors of engineering for a wide range of different components and machine elements, as a high-grade electrical insulation material and for many special applications.

Ultramid® (PA)

ULTRAMID® INJECTION-MOLDING GRADES WITHOUT FLAME RETARDANTS	04
Unreinforced Ultramid® A grades	04
Reinforced Ultramid® A grades	06
Unreinforced Ultramid® B grades	12
Reinforced Ultramid® B grades	14
Ultramid® Endure grades	20
Ultramid® S Balance grades	22
Ultramid® Structure	24
Unreinforced Ultramid® T grades, reinforced Ultramid® T grades	26
Ultramid® Advanced unreinforced, Ultramid® Advanced reinforced	28
ULTRAMID® INJECTION-MOLDING GRADES WITH FLAME RETARDANTS	32
Unreinforced grades	32
Reinforced grades	34
Reinforced Ultramid® T grades and Ultramid® ONE J grade	38
Reinforced Ultramid® Advanced grades	40
NOMENCLATURE	42

Ultramid® – Injection-molding grades without flame retardants

Unreinforced Ultramid® A grades

Values at 23°C ¹⁾	Unit	Test specification	Condition
Features			
Polymer abbreviation	–	–	–
Density	kg/m ³	ISO 1183	–
Viscosity number (0.005 g/ml sulphuric acid)	cm ³ /g	ISO 307	–
Water absorption, equilibrium in water at 23 °C	%	ISO 62	–
Moisture absorption, equilibrium in standard cond. 23 °C/50 % r.h.	%	ISO 62	–
Processing			
Melting temperature, DSC	°C	ISO 11357-1/-3	–
Melt volume-flow rate MVR, test temperature (load)	cm ³ /10 min, °C (kg)	ISO 1133	–
Melt temperature injection moulding	°C	–	–
Mold temperature injection moulding	°C	–	–
Molding shrinkage, test box, d = 1.5 mm, T _M (T _w) ⁴⁾	%, °C (°C)	–	–
Molding shrinkage parallel (perpendicular)	%	ISO 294-4	–
Flammability			
Flammability acc. to UL 94, d = 1.6 mm	class	IEC 60695-11-10	–
Testing of materials for automobile interior, burning rate ≤ 100 mm/min, d ≥ 1 mm ⁵⁾	–	ISO 3795, FMVSS 302	–
Mechanical properties			
Tensile modulus of elasticity	MPa	ISO 527-1/-2	dry/cond.
Yield stress (v = 50 mm/min), (Stress at break (v = 5 mm/min))*	MPa	ISO 527-1/-2	dry/cond.
Yield strain (v = 50 mm/min), (Strain at break (v = 5 mm/min))*	%	ISO 527-1/-2	dry/cond.
Tensile creep modulus, 1,000 h, elongation ≤ 0.5 %, +23 °C	MPa	ISO 899-1	cond.
Flexural modulus	MPa	ISO 178	dry/cond.
Flexural stress at max. force	MPa	ISO 178	dry/cond.
Charpy unnotched impact strength, 23 °C ³⁾	kJ/m ²	ISO 179/1eU	dry/cond.
Charpy unnotched impact strength, -30 °C	kJ/m ²	ISO 179/1eU	dry/cond.
Charpy notched impact strength, 23 °C ³⁾	kJ/m ²	ISO 179/1eA	dry/cond.
Charpy notched impact strength, -30 °C	kJ/m ²	ISO 179/1eA	dry/cond.
Thermal properties			
Heat distortion temperature under 1.8 MPa load (HDT A)	°C	ISO 75-1/-2	–
Heat distortion temperature under 0.45 MPa load (HDT B)	°C	ISO 75-1/-2	–
Max. service temperature, up to a few hours ²⁾	°C	–	–
Temperature index for 50 % loss of tensile strength after 20,000 h (5,000 h)	°C	IEC 60216	–
Thermal conductivity, 23 °C	W/(m · K)	DIN 52612-1	–
Specific heat capacity, 23 °C	J/(kg · K)	–	–
Coeff. of linear therm. expansion 23 °C - 55 °C, parallel (perpendicular)	10 ⁻⁶ /K	ISO 11359-1/-2	–
Electrical properties			
Dielectric constant at 1 MHz	–	IEC 62631-2-1	dry/cond.
Dissipation factor at 1 MHz	10 ⁻⁴	IEC 62631-2-1	dry/cond.
Volume resistivity	Ω · m	IEC 62631-3-1	dry/cond.
Surface resistivity	Ω	IEC 62631-3-2	dry/cond.
CTI, test liquid A	–	IEC 60112	–
Core Products			

Footnotes

- ¹⁾ For undyed product, unless otherwise indicated in the product designation.
²⁾ Empirical values for parts repeatedly exposed to this temperature for several hours at a time over a period of years, provided that shaping and processing were in accord with the material.
³⁾ N = not broken
⁴⁾ Test box with central gating, base dimensions (107 · 47 · 1.5) mm.
⁵⁾ + = Passed

A3K	A3W	A3Z	A4H
PA66	PA66	PA66-I	PA66
1,130	1,130	1,060	1,130
150	150	–	190
8-9	8-9	6.7-7.7	8-9
2.50-3.10	2.50-3.10	2.00-2.60	2.50-3.10
260	260	260	260
120, 275 (5)	100, 275 (5)	10, 275 (10)	40, 275 (5)
280-300	280-300	280-300	280-300
60-80	60-80	60-80	60-80
0.95, 290 (60)	0.81, 290 (60)	0.85, 290 (80)	0.9, 290 (60)
1.50 (1.80)	1.50 (1.80)	–	1.60 (1.80)
V-2 (A3K R01)	V-2	HB	V-2 (A4H R01)
+	+	+	+
3,000/1,100	3,000/1,100	1,800/700	3,000/1,200
85/50	85/50	45/30	80/50
4.5/20	4.4/20	4.5/40	4.2/23
700	700	450	700
2,900/–	2,900/–	1,750/–	2,900/1,200
–/–	–	64/–	80/45
N/N	N/N	N/N	N/N
–	–	N/N	210/250
5/20	6/20	90/115	6.0/19.7
4/–	5/–	70/70	4.9/4.5
75	75	60	75
220	220	125	220
200	200	200	200
101 (118)	109 (130)	–	118 (138)
0.33	0.33	0.33	0.33
1,700	1,700	1,700	1,700
98	98	120 (133)	98
3.2/5	3.2/5	3.1/3.6	3.2/5
250/2,000	250/2,000	160/700	250/2,000
10 ¹³ /10 ¹⁰	10 ¹³ /10 ⁹	40 ¹² /10 ¹⁰	10 ¹³ /10 ¹⁰
* /10 ¹⁰	* /10 ⁹	* /10 ¹²	* /10 ¹⁰
600	500	600	600
FC, UN, SW00464	UN, SW00464	UN, SW30464	UN00002, SW00465

Easy flowing injection-molding grade for fast processing. Uses include highly stressed technical parts such as bearings and gear wheels; also electrically insulating parts such as terminals and cable connectors. FC grades suitable for food contact applications.

Free-flowing, heat aging resistant and rapidly processable grade for technical parts subject to high stress such as bearings and bearing cages, gearwheels, spool bodies and cable connectors.

Impact-modified and stabilized injection-molding grade for components and housings with good low temperature impact resistance.

Highly heat aging resistant, medium-viscosity injection-molding grade for highly stressed parts such as bearing cages, gearwheels, spool bodies and cable connectors.

Ultramid® – Injection-molding grades without flame retardants

Reinforced Ultramid® A grades

Values at 23°C ¹⁾	Unit	Test specification	Condition
Features			
Polymer abbreviation	–	–	–
Density	kg/m ³	ISO 1183	–
Viscosity number (0.005 g/ml sulphuric acid)	cm ³ /g	ISO 307	–
Water absorption, equilibrium in water at 23 °C	%	ISO 62	–
Moisture absorption, equilibrium in standard cond. 23 °C/50 % r.h.	%	ISO 62	–
Processing			
Melting temperature, DSC	°C	ISO 11357-1/-3	–
Melt volume-flow rate MVR, test temperature (load)	cm ³ /10 min, °C (kg)	ISO 1133	–
Melt temperature injection moulding	°C	–	–
Mold temperature injection moulding	°C	–	–
Molding shrinkage, test box, d = 1.5 mm, T _M (T _W) ⁴⁾	%, °C (°C)	–	–
Molding shrinkage parallel (perpendicular)	%	ISO 294-4	–
Flammability			
Flammability acc. to UL 94, d = 1.6 mm	class	IEC 60695-11-10	–
Testing of materials for automobile interior, burning rate ≤ 100 mm/min, d ≥ 1 mm ⁵⁾	–	ISO 3795, FMVSS 302	–
Mechanical properties			
Tensile modulus of elasticity	MPa	ISO 527-1/-2	dry/cond.
Yield stress (v = 50 mm/min), (Stress at break (v = 5 mm/min))*	MPa	ISO 527-1/-2	dry/cond.
Yield strain (v = 50 mm/min), (Strain at break (v = 5 mm/min))*	%	ISO 527-1/-2	dry/cond.
Tensile creep modulus, 1,000 h, elongation ≤ 0.5 %, +23 °C	MPa	ISO 899-1	cond.
Flexural modulus	MPa	ISO 178	dry/cond.
Flexural stress at max. force	MPa	ISO 178	dry/cond.
Charpy unnotched impact strength, 23 °C ³⁾	kJ/m ²	ISO 179/1eU	dry/cond.
Charpy unnotched impact strength, -30 °C	kJ/m ²	ISO 179/1eU	dry/cond.
Charpy notched impact strength, 23 °C ³⁾	kJ/m ²	ISO 179/1eA	dry/cond.
Charpy notched impact strength, -30 °C	kJ/m ²	ISO 179/1eA	dry/cond.
Thermal properties			
Heat distortion temperature under 1.8 MPa load (HDT A)	°C	ISO 75-1/-2	–
Heat distortion temperature under 0.45 MPa load (HDT B)	°C	ISO 75-1/-2	–
Max. service temperature, up to a few hours ²⁾	°C	–	–
Temperature index for 50 % loss of tensile strength after 20,000 h (5,000 h)	°C	IEC 60216	–
Thermal conductivity, 23 °C	W/(m · K)	DIN 52612-1	–
Specific heat capacity, 23 °C	J/(kg · K)	–	–
Coeff. of linear therm. expansion 23 °C - 55 °C, parallel (perpendicular)	10 ⁻⁶ /K	ISO 11359-1/-2	–
Electrical properties			
Dielectric constant at 1 MHz	–	IEC 62631-2-1	dry/cond.
Dissipation factor at 1 MHz	10 ⁻⁴	IEC 62631-2-1	dry/cond.
Volume resistivity	Ω · m	IEC 62631-3-1	dry/cond.
Surface resistivity	Ω	IEC 62631-3-2	dry/cond.
CTI, test liquid A	–	IEC 60112	–
Core Products			

Footnotes

¹⁾ For undyed product, unless otherwise indicated in the product designation.

²⁾ Empirical values for parts repeatedly exposed to this temperature for several hours at a time over a period of years, provided that shaping and processing were in accord with the material.

³⁾ N = not broken

⁴⁾ Test box with central gating, base dimensions (107 · 47 · 1.5) mm.

⁵⁾ + = Passed

A3WG3	A3EG5	A3HG5	A3WG5	A3EG6	A3WG6
PA66-GF15	PA66-GF25	PA66-GF25	PA66-GF25	PA66-GF30	PA66-GF30
1,230	1,320	1,320	1,320	1,360	1,360
145	145	145	145	145	145
6.7 - 7.3	5.7 - 6.3	5.7 - 6.3	5.7 - 6.3	5.2 - 5.8	5.2 - 5.8
1.90-2.50	1.70-2.10	1.70-2.10	1.70-2.10	1.50-1.90	1.50-1.90
260	260	260	260	260	260
60, 275 (5)	50, 275 (5)	40, 275 (5)	40, 275 (5)	30, 275 (5)	30, 275 (5)
280-300	280-300	280-300	280-300	280-300	280-300
0.75, 290 (80)	80-90	80-90	80-90	80-90	80-90
0.75 (1.13)	0.55, 290 (80)	0.55, 290 (80)	0.48, 290 (80)	0.55, 290 (80)	0.49, 290 (80)
–	0.43 (1.03)	0.48 (1.06)	0.43 (1.01)	0.53 (1.02)	0.38 (0.93)
HB	HB	HB	HB	HB	HB
+	+	+	+	+	+
6,000/4,500	8,600/6,500	8,500/5,900	8,600/6,500	10,000/7,200	10,000/7,200
130*/85*	175*/120*	175/115	180*/120*	190*/130*	190*/130*
3*/10*	3*/6*	3.9/8.2	3*/6*	3*/5*	3*/5*
2,600	4,300	4,300	4,400	5,300	5,300
5,500/4,000	7,600/6,000	7,900/5,500	7,600/6,000	8,600/6,500	8,600/6,500
200/125	260/200	275/185	260/200	280/210	280/210
45/70	65/90	70/95	65/90	85/100	85/100
43/–	55/50	60/60	55/–	70/70	70/–
8/11	12/10	9.8/12.8	12/18	13/12	13/22
7/–	9/7.7	8.2/7.8	9/–	11/9.5	10/–
240	245	245	245	250	250
250	260	260	250	260	250
240	240	240	240	240	240
145 (175)	135 (165)	140 (170)	145 (175)	135 (165)	145 (175)
0.33	0.34	0.34	0.34	0.35	0.35
1,800	1,240	1,600	1,600	1,260	1,500
33 (101)	28 (97)	28 (97)	28 (97)	28 (88)	27 (86)
3.5/5.5	3.7/4.3	3.5/5.5	3.5/5.5	3.7/4.3	3.5/5.6
140/3,000	210/810	140/1,600	140/3,000	210/810	140/3,000
10 ¹³ /10 ¹⁰	10 ¹³ /10 ¹⁰	10 ¹³ /10 ¹⁰	10 ¹³ /10 ¹⁰	10 ¹³ /10 ¹⁰	10 ¹³ /10 ¹⁰
*/10 ¹⁰	*/10 ¹⁰	*/10 ¹⁰	*/10 ¹⁰	*/10 ¹⁰	*/10 ¹⁰
450	550	550	450	550	450
UN, SW00564	UN, SW00564	UN00002, SW00565, SW00566	UN, SW00564	UN, SW00564, FC	UN, SW00564

Glass-fiber reinforced and heat aging resistant injection-molding grade for machine elements and housings of medium stiffness. For electric insulating parts, preference should be given to the grades A3EG3.

Glass-fiber reinforced injection-molding grade for machine elements and housings of high stiffness and dimensional stability such as spool bodies and bearing cages as well as for electric insulating parts.

Glass-fiber reinforced and heat aging resistant injection-molding grade for machine elements and housings of high stiffness and dimensional stability such as spool bodies, sensors and bearing cages as well as for electric insulating parts.

Glass-fiber reinforced and heat aging resistant injection-molding grade for machine elements and housings of high stiffness and dimensional stability such as spool bodies and bearing cages. For electric insulating parts, preference should be given to grades A3EG5 and A3HG5.

Glass-fiber reinforced injection-molding grade for machine elements and housings of high stiffness and dimensional stability such as fans, insulating profiles for aluminum windows as well as for electric insulating parts, electronic housings. As FC grade suitable for food contact.

Glass-fiber reinforced and heat aging resistant injection-molding grade for machine elements and housings of high stiffness and dimensional stability such as oil pans, cylinder head covers, sensors, fans and insulating profiles for aluminum windows. For electric insulating parts, preference should be given to grade A3EG6.

Ultramid® – Injection-molding grades without flame retardants

Reinforced Ultramid® A grades

Values at 23°C ¹⁾	Unit	Test specification	Condition
Features			
Polymer abbreviation	–	–	–
Density	kg/m ³	ISO 1183	–
Viscosity number (0.005 g/ml sulphuric acid)	cm ³ /g	ISO 307	–
Water absorption, equilibrium in water at 23 °C	%	ISO 62	–
Moisture absorption, equilibrium in standard cond. 23 °C/50 % r.h.	%	ISO 62	–
Processing			
Melting temperature, DSC	°C	ISO 11357-1/-3	–
Melt volume-flow rate MVR, test temperature (load)	cm ³ /10 min, °C (kg)	ISO 1133	–
Melt temperature injection moulding	°C	–	–
Mold temperature injection moulding	°C	–	–
Molding shrinkage, test box, d = 1.5 mm, T _M (T _W) ⁴⁾	%, °C (°C)	–	–
Molding shrinkage parallel (perpendicular)	%	ISO 294-4	–
Flammability			
Flammability acc. to UL 94, d = 1.6 mm	class	IEC 60695-11-10	–
Testing of materials for automobile interior, burning rate ≤ 100 mm/min, d ≥ 1 mm ⁵⁾	–	ISO 3795, FMVSS 302	–
Mechanical properties			
Tensile modulus of elasticity	MPa	ISO 527-1/-2	dry/cond.
Yield stress (v = 50 mm/min), (Stress at break (v = 5 mm/min))*	MPa	ISO 527-1/-2	dry/cond.
Yield strain (v = 50 mm/min), (Strain at break (v = 5 mm/min))*	%	ISO 527-1/-2	dry/cond.
Tensile creep modulus, 1,000 h, elongation ≤ 0.5 %, +23 °C	MPa	ISO 899-1	cond.
Flexural modulus	MPa	ISO 178	dry/cond.
Flexural stress at max. force	MPa	ISO 178	dry/cond.
Charpy unnotched impact strength, 23 °C ³⁾	kJ/m ²	ISO 179/1eU	dry/cond.
Charpy unnotched impact strength, -30 °C	kJ/m ²	ISO 179/1eU	dry/cond.
Charpy notched impact strength, 23 °C ³⁾	kJ/m ²	ISO 179/1eA	dry/cond.
Charpy notched impact strength, -30 °C	kJ/m ²	ISO 179/1eA	dry/cond.
Thermal properties			
Heat distortion temperature under 1.8 MPa load (HDT A)	°C	ISO 75-1/-2	–
Heat distortion temperature under 0.45 MPa load (HDT B)	°C	ISO 75-1/-2	–
Max. service temperature, up to a few hours ²⁾	°C	–	–
Temperature index for 50 % loss of tensile strength after 20,000 h (5,000 h)	°C	IEC 60216	–
Thermal conductivity, 23 °C	W/(m · K)	DIN 52612-1	–
Specific heat capacity, 23 °C	J/(kg · K)	–	–
Coeff. of linear therm. expansion 23 °C - 55 °C, parallel (perpendicular)	10 ⁻⁶ /K	ISO 11359-1/-2	–
Electrical properties			
Dielectric constant at 1 MHz	–	IEC 62631-2-1	dry/cond.
Dissipation factor at 1 MHz	10 ⁻⁴	IEC 62631-2-1	dry/cond.
Volume resistivity	Ω · m	IEC 62631-3-1	dry/cond.
Surface resistivity	Ω	IEC 62631-3-2	dry/cond.
CTI, test liquid A	–	IEC 60112	–
Core Products			

Footnotes

- ¹⁾ For undyed product, unless otherwise indicated in the product designation.
²⁾ Empirical values for parts repeatedly exposed to this temperature for several hours at a time over a period of years, provided that shaping and processing were in accord with the material.
³⁾ N = not broken
⁴⁾ Test box with central gating, base dimensions (107 · 47 · 1.5) mm.
⁵⁾ + = Passed

A3HG6 HR	A3EG7	A3HG7	A3WG7	A3WG7 HRX	A3WG8
PA66-GF30	PA66-GF35	PA66-GF35	PA66-GF35	PA66-GF35	PA66-GF40
1,370	1,410	1,410	1,410	1,420	1,460
145	145	145	145	155	140
5.2 - 5.8	4.7 - 5.3	4.7 - 5.3	4.7 - 5.3	5 - 5.7	4.4 - 5
1.50 - 1.90	1.40 - 1.80	1.40 - 1.80	1.40 - 1.80	1.40 - 1.80	1.30 - 1.70
260	260	260	260	260	260
20, 275 (5)	30, 275 (5)	30, 275 (5)	20, 275 (5)	10, 275 (5)	20, 275 (5)
280 - 300	280 - 300	280 - 300	280 - 300	280 - 310	280 - 300
80 - 90	80 - 90	80 - 90	80 - 90	80 - 90	80 - 90
0.55, 290 (80)	0.49, 290 (80)	0.40, 290 (80)	0.5, 290 (80)	0.4 - 0.5, 290 (80)	0.4, 290 (80)
0.47 (1.15)	0.48 (1.00)	0.50 (0.80)	0.37 (1.04)	0.40 (1.10)	0.35 (1.02)
–	HB	HB	HB	–	–
+	+	+	+	+	+
10,000/6,800	11,500/8,500	11,400/8,500	11,500/8,500	11,000/7,300	13,000/8,500
190*/120*	210*/150*	210/150	210*/150*	205*/130*	220*/145*
3.2*/5.4*	3*/5*	3.5/5.8	3*/5*	3.4*/5.7*	3*/5*
5,300	6,650	6,600	6,600	4,100	4,900
8,700/5,800	10,000/8,000	10,500/8,100	10,000/8,000	10,500/7,000	12,200/8,400
275/200	300/240	320/230	300/240	310/200	330/230
90/93	95/107	100/105	95/105	100/105	100/110
71/60.7	75/77	80/80	75/–	85/95	85/95
10.4/13	14/22	14.0/17.4	14/22	12/17	13/17
12/6.8	12/–	11.2/10.6	12/–	9.5/10	10/11
250	250	250	250	250	250
260	260	260	250	260	260
240	240	240	240	240	240
–	135 (165)	140 (170)	145 (175)	–	–
0.34	0.35	0.35	0.35	0.37	0.41
1,500	1,250	1,500	1,500	1,200	1,200
27 (106)	22 (93)	22 (93)	22 (93)	23 (96)	23 (86)
3.5/5.6	3.8/4.5	3.5/5.7	3.5/5.7	3.9/4.7	4/4.7
–/3,000	210/830	200/1,500	200/3,000	180/910	170/830
10 ¹³ /10 ¹⁰	10 ¹³ /10 ¹⁰	10 ¹³ /10 ¹⁰	10 ¹³ /10 ¹⁰	20 ¹² /20 ⁸	30 ¹² /50 ¹⁰
*/10 ¹⁰	*/10 ¹⁰	*/10 ¹⁰	*/10 ¹⁰	*/60 ¹²	*/20 ¹³
450	550	550	450	350	425
SW23591	UN, SW00564, FC	UN00002, SW00565, SW00566	UN, SW00564	SW23591	SW20560

Glass-fiber reinforced injection-molding grade with enhanced hydrolysis resistance, e. g., for applications in vehicle cooling systems and sensors.

Glass-fiber reinforced injection-molding grade for machine elements and housings of high stiffness and dimensional stability such as heat pump housings, electronic housings instantaneous water heaters as well as for electric insulating parts, as FC grade suitable for food contact.

Glass-fiber reinforced and heat aging resistant injection-molding grade, e. g. for parts and components with high stiffness and dimensional stability as well as electrically insulating parts.

Glass-fiber reinforced and heat aging resistant injection-molding grade for technical articles such as gearwheels, solenoid valve housings, cable contacts, oil pans, cylinder head covers, engine brackets, chassis stiffeners and components for automotive gear shifting systems.

Glass-fiber reinforced injection-molding grade with enhanced resistance to hydrolysis and heat ageing, e. g. for applications in the automotive cooling circuit and battery cooling.

Glass-fiber reinforced and heat-aging resistant injection-molding grade for industrial items such as gear wheels, solenoid valve housings, cable attachments, automotive fuel distributors, cylinder head covers and components for automotive gearshift.

Ultramid® – Injection-molding grades without flame retardants

Reinforced Ultramid® A grades

Values at 23°C ¹⁾	Unit	Test specification	Condition
Features			
Polymer abbreviation	–	–	–
Density	kg/m ³	ISO 1183	–
Viscosity number (0.005 g/ml sulphuric acid)	cm ³ /g	ISO 307	–
Water absorption, equilibrium in water at 23 °C	%	ISO 62	–
Moisture absorption, equilibrium in standard cond. 23 °C/50 % r.h.	%	ISO 62	–
Processing			
Melting temperature, DSC	°C	ISO 11357-1/-3	–
Melt volume-flow rate MVR, test temperature (load)	cm ³ /10 min, °C (kg)	ISO 1133	–
Melt temperature injection moulding	°C	–	–
Mold temperature injection moulding	°C	–	–
Molding shrinkage, test box, d = 1.5 mm, T _M (T _W) ⁴⁾	%, °C (°C)	–	–
Molding shrinkage parallel (perpendicular)	%	ISO 294-4	–
Flammability			
Flammability acc. to UL 94, d = 1.6 mm	class	IEC 60695-11-10	–
Testing of materials for automobile interior, burning rate ≤ 100 mm/min, d ≥ 1 mm ⁵⁾	–	ISO 3795, FMVSS 302	–
Mechanical properties			
Tensile modulus of elasticity	MPa	ISO 527-1/-2	dry/cond.
Yield stress (v = 50 mm/min), (Stress at break (v = 5 mm/min))*	MPa	ISO 527-1/-2	dry/cond.
Yield strain (v = 50 mm/min), (Strain at break (v = 5 mm/min))*	%	ISO 527-1/-2	dry/cond.
Tensile creep modulus, 1,000 h, elongation ≤ 0.5 %, +23 °C	MPa	ISO 899-1	cond.
Flexural modulus	MPa	ISO 178	dry/cond.
Flexural stress at max. force	MPa	ISO 178	dry/cond.
Charpy unnotched impact strength, 23 °C ³⁾	kJ/m ²	ISO 179/1eU	dry/cond.
Charpy unnotched impact strength, -30 °C	kJ/m ²	ISO 179/1eU	dry/cond.
Charpy notched impact strength, 23 °C ³⁾	kJ/m ²	ISO 179/1eA	dry/cond.
Charpy notched impact strength, -30 °C	kJ/m ²	ISO 179/1eA	dry/cond.
Thermal properties			
Heat distortion temperature under 1.8 MPa load (HDT A)	°C	ISO 75-1/-2	–
Heat distortion temperature under 0.45 MPa load (HDT B)	°C	ISO 75-1/-2	–
Max. service temperature, up to a few hours ²⁾	°C	–	–
Temperature index for 50 % loss of tensile strength after 20,000 h (5,000 h)	°C	IEC 60216	–
Thermal conductivity, 23 °C	W/(m · K)	DIN 52612-1	–
Specific heat capacity, 23 °C	J/(kg · K)	–	–
Coeff. of linear therm. expansion 23 °C - 55 °C, parallel (perpendicular)	10 ⁻⁶ /K	ISO 11359-1/-2	–
Electrical properties			
Dielectric constant at 1 MHz	–	IEC 62631-2-1	dry/cond.
Dissipation factor at 1 MHz	10 ⁻⁴	IEC 62631-2-1	dry/cond.
Volume resistivity	Ω · m	IEC 62631-3-1	dry/cond.
Surface resistivity	Ω	IEC 62631-3-2	dry/cond.
CTI, test liquid A	–	IEC 60112	–
Core Products			

Footnotes

¹⁾ For undyed product, unless otherwise indicated in the product designation.

²⁾ Empirical values for parts repeatedly exposed to this temperature for several hours at a time over a period of years, provided that shaping and processing were in accord with the material.

³⁾ N = not broken

⁴⁾ Test box with central gating, base dimensions (107 · 47 · 1.5) mm.

⁵⁾ + = Passed

A3EG10	A3WG10	A3WGM53	A3ZG6
PA66-GF50	PA66-GF50	(PA66+PA6) - (GF25+M15)	PA66-I GF30
1,560	1,560	1,480	1,330
130	130	136	160
3.7 - 4.3	3.7 - 4.3	4.8 - 5.4	4.7 - 5.3
1.00 - 1.40	1.00 - 1.40	1.20 - 1.60	1.30 - 1.70
260	260	260	260
8, 275 (5)	10, 275 (5)	30, 275 (5)	15, 275 (5)
280 - 310	290 - 310	280 - 300	280 - 300
80 - 90	80 - 90	80 - 90	80 - 90
0.46, 300 (80)	0.42, 300 (80)	0.6, 290 (80)	0.55, 290 (80)
0.33 (0.82)	0.35 (0.95)	0.31 (0.70)	–
HB	HB	–	HB
+	+	+	+
16,800/12,500	16,800/12,500	12,100/6,100	8,500/6,000
240*/180*	240*/180*	160*/80*	140*/100*
2.5*/3.5*	2.5*/3.5*	2.3*/6*	3.5*/6*
7,800	7,800	–	3,000
15,000/13,500	15,000/13,500	10,100/5,500	7,300/4,900
360/300	360/300	225/125	210/150
95/100	95/100	55/62	90/95
90/–	90/103	50/–	85/–
18/25	18/25	8/16	19/26
13/–	13/12.6	6.7/–	10/–
250	250	225	240
260	250	250	250
240	240	240	220
135 (165)	145 (175)	145 (175)	–
0.37	0.37	0.35	0.35
1,300	1,300	1,500	1,700
16 (80)	16 (80)	27 (84)	27 (128)
3.8/6.6	3.8/6.6	4/–	3.5/5.5
150/1,700	150/3,000	200/–	140/1,600
10 ¹³ /10 ¹⁰	10 ¹³ /10 ¹⁰	10 ¹³ /10 ¹⁰	10 ¹³ /10 ¹⁰
*/10 ¹⁰	*/10 ¹⁰	*/10 ¹⁰	*/10 ¹⁰
550	550	375	550
UN, FC	UN, SW00564, HP SW23325	SW20560	SW20591

Glass-fiber reinforced injection-molding grade for technical articles of very high stiffness as well as for electric insulating parts. As FC type suitable for food contact.

Glass-fiber reinforced injection-molding grade with high heat aging resistance for technical articles of very high stiffness, e.g. motor brackets or gearbox carriers.

Combined glass-fiber and mineral-fiber reinforced injection-molding grade for the manufacture of parts having high stiffness and good dimensional stability as well as surface quality, for example, cylinder head covers for vehicles.

Impact-modified, glass-fiber reinforced injection-molding grade.

Ultramid® – Injection-molding grades without flame retardants

Unreinforced Ultramid® B grades

Values at 23°C ¹⁾	Unit	Test specification	Condition
Features			
Polymer abbreviation	–	–	–
Density	kg/m ³	ISO 1183	–
Viscosity number (0.005 g/ml sulphuric acid)	cm ³ /g	ISO 307	–
Water absorption, equilibrium in water at 23 °C	%	ISO 62	–
Moisture absorption, equilibrium in standard cond. 23 °C/50 % r.h.	%	ISO 62	–
Processing			
Melting temperature, DSC	°C	ISO 11357-1/-3	–
Melt volume-flow rate MVR, test temperature (load)	cm ³ /10 min, °C (kg)	ISO 1133	–
Melt temperature injection moulding	°C	–	–
Mold temperature injection moulding	°C	–	–
Molding shrinkage, test box, d = 1.5 mm, T _M (T _w) ⁴⁾	%, °C (°C)	–	–
Molding shrinkage parallel (perpendicular)	%	ISO 294-4	–
Flammability			
Flammability acc. to UL 94, d = 1.6 mm	class	IEC 60695-11-10	–
Testing of materials for automobile interior, burning rate ≤ 100 mm/min, d ≥ 1 mm ⁵⁾	–	ISO 3795, FMVSS 302	–
Mechanical properties			
Tensile modulus of elasticity	MPa	ISO 527-1/-2	dry/cond.
Yield stress (v = 50 mm/min), (Stress at break (v = 5 mm/min))*	MPa	ISO 527-1/-2	dry/cond.
Yield strain (v = 50 mm/min), (Strain at break (v = 5 mm/min))*	%	ISO 527-1/-2	dry/cond.
Tensile creep modulus, 1,000 h, elongation ≤ 0.5 %, +23 °C	MPa	ISO 899-1	cond.
Flexural modulus	MPa	ISO 178	dry/cond.
Flexural stress at max. force	MPa	ISO 178	dry/cond.
Charpy unnotched impact strength, 23 °C ³⁾	kJ/m ²	ISO 179/1eU	dry/cond.
Charpy unnotched impact strength, -30 °C	kJ/m ²	ISO 179/1eU	dry/cond.
Charpy notched impact strength, 23 °C ³⁾	kJ/m ²	ISO 179/1eA	dry/cond.
Charpy notched impact strength, -30 °C	kJ/m ²	ISO 179/1eA	dry/cond.
Thermal properties			
Heat distortion temperature under 1.8 MPa load (HDT A)	°C	ISO 75-1/-2	–
Heat distortion temperature under 0.45 MPa load (HDT B)	°C	ISO 75-1/-2	–
Max. service temperature, up to a few hours ²⁾	°C	–	–
Temperature index for 50 % loss of tensile strength after 20,000 h (5,000 h)	°C	IEC 60216	–
Thermal conductivity, 23 °C	W/(m · K)	DIN 52612-1	–
Specific heat capacity, 23 °C	J/(kg · K)	–	–
Coeff. of linear therm. expansion 23 °C - 55 °C, parallel (perpendicular)	10 ⁻⁶ /K	ISO 11359-1/-2	–
Electrical properties			
Dielectric constant at 1 MHz	–	IEC 62631-2-1	dry/cond.
Dissipation factor at 1 MHz	10 ⁻⁴	IEC 62631-2-1	dry/cond.
Volume resistivity	Ω · m	IEC 62631-3-1	dry/cond.
Surface resistivity	Ω	IEC 62631-3-2	dry/cond.
CTI, test liquid A	–	IEC 60112	–
Core Products			

Footnotes

- ¹⁾ For undyed product, unless otherwise indicated in the product designation.
- ²⁾ Empirical values for parts repeatedly exposed to this temperature for several hours at a time over a period of years, provided that shaping and processing were in accord with the material.
- ³⁾ N = not broken
- ⁴⁾ Test box with central gating, base dimensions (107 · 47 · 1.5) mm.
- ⁵⁾ + = Passed

B3K	B3L	B3S	B3Z2
PA6	PA6-I	PA6	PA6-I
1,130	1,100	1,130	1,090
150	–	145	–
9 - 10	8.5 - 9.5	9 - 10	8 - 9
2.60 - 3.40	2.10 - 2.90	2.60 - 3.40	2.8
220	220	220	220
160, 275 (5)	100, 275 (5)	160, 275 (5)	100, 275 (5)
250 - 270	250 - 270	250 - 270	250 - 270
40 - 60	40 - 60	40 - 60	40 - 60
0.65, 260 (60)	0.65, 260 (60)	0.40, 260 (80)	0.95, 260 (60)
0.75 (0.75)	1.30 (1.50)	0.90 (0.90)	1.30 (1.40)
HB	HB	V-2 (B3S R03)	–
+	+	+	+
3,100/1,000	2,800/900	3,500/1,200	2,090/650
85/40	70/35	90/45	57/30
4/20	3.5/18	4/20	4/20
700	550	1,100	–
2,800/–	2,300/–	3,000/–	1,800/–
–	–	–	–
N/N	N/N	250/N	N/N
100/–	N/–	200/–	N/–
5.5/60	10/N	4/50	56/128
4/–	6/–	3/–	20/–
60	55	65	60
180	150	180	–
180	160	180	180
100 (112)	–	87 (97)	–
0.33	0.32	0.33	–
1,700	1,500	1,700	–
102	93 (140)	102	–
3.5/7	3.5/6.4	3.3/7	3.4/–
230/3,000	240/2,400	300/3,000	150/–
10 ¹³ /10 ¹⁰	10 ¹³ /10 ¹⁰	10 ¹³ /10 ¹⁰	>10 ¹³ /–
* /10 ¹⁰	* /10 ¹⁰	* /10 ¹⁰	–
600	600	600	–
UN, SW00464	UN, SW00464	UN, SW00464	UN, SW802

Easy flowing and stabilized injection-molding grade used for technical parts e.g. machinery components or fans.

Impact-modified, free-flowing and rapidly processable injection-molding grade for dry impact-resistant technical articles, e.g. housings, fittings and wall plugs.

Easy flowing, finely crystalline injection-molding grade for very fast processing. Uses include thin-walled technical parts e.g. housings, fittings, grips, and fixing clamps.

Injection moulding grade, easy flowing, short cycle time, dry-impact, conditioning free technical moulded parts.

Ultramid® – Injection-molding grades without flame retardants

Reinforced Ultramid® B grades

Values at 23°C ¹⁾	Unit	Test specification	Condition
Features			
Polymer abbreviation	–	–	–
Density	kg/m ³	ISO 1183	–
Viscosity number (0.005 g/ml sulphuric acid)	cm ³ /g	ISO 307	–
Water absorption, equilibrium in water at 23 °C	%	ISO 62	–
Moisture absorption, equilibrium in standard cond. 23 °C/50 % r.h.	%	ISO 62	–
Processing			
Melting temperature, DSC	°C	ISO 11357-1/-3	–
Melt volume-flow rate MVR, test temperature (load)	cm ³ /10 min, °C (kg)	ISO 1133	–
Melt temperature injection moulding	°C	–	–
Mold temperature injection moulding	°C	–	–
Molding shrinkage, test box, d = 1.5 mm, T _M (T _W) ⁴⁾	%, °C (°C)	–	–
Molding shrinkage parallel (perpendicular)	%	ISO 294-4	–
Flammability			
Flammability acc. to UL 94, d = 1.6 mm	class	IEC 60695-11-10	–
Testing of materials for automobile interior, burning rate ≤ 100 mm/min, d ≥ 1 mm ⁵⁾	–	ISO 3795, FMVSS 302	–
Mechanical properties			
Tensile modulus of elasticity	MPa	ISO 527-1/-2	dry/cond.
Yield stress (v = 50 mm/min), (Stress at break (v = 5 mm/min))*	MPa	ISO 527-1/-2	dry/cond.
Yield strain (v = 50 mm/min), (Strain at break (v = 5 mm/min))*	%	ISO 527-1/-2	dry/cond.
Tensile creep modulus, 1,000 h, elongation ≤ 0.5 %, +23 °C	MPa	ISO 899-1	cond.
Flexural modulus	MPa	ISO 178	dry/cond.
Flexural stress at max. force	MPa	ISO 178	dry/cond.
Charpy unnotched impact strength, 23 °C ³⁾	kJ/m ²	ISO 179/1eU	dry/cond.
Charpy unnotched impact strength, -30 °C	kJ/m ²	ISO 179/1eU	dry/cond.
Charpy notched impact strength, 23 °C ³⁾	kJ/m ²	ISO 179/1eA	dry/cond.
Charpy notched impact strength, -30 °C	kJ/m ²	ISO 179/1eA	dry/cond.
Thermal properties			
Heat distortion temperature under 1.8 MPa load (HDT A)	°C	ISO 75-1/-2	–
Heat distortion temperature under 0.45 MPa load (HDT B)	°C	ISO 75-1/-2	–
Max. service temperature, up to a few hours ²⁾	°C	–	–
Temperature index for 50 % loss of tensile strength after 20,000 h (5,000 h)	°C	IEC 60216	–
Thermal conductivity, 23 °C	W/(m · K)	DIN 52612-1	–
Specific heat capacity, 23 °C	J/(kg · K)	–	–
Coeff. of linear therm. expansion 23 °C - 55 °C, parallel (perpendicular)	10 ⁻⁶ /K	ISO 11359-1/-2	–
Electrical properties			
Dielectric constant at 1 MHz	–	IEC 62631-2-1	dry/cond.
Dissipation factor at 1 MHz	10 ⁻⁴	IEC 62631-2-1	dry/cond.
Volume resistivity	Ω · m	IEC 62631-3-1	dry/cond.
Surface resistivity	Ω	IEC 62631-3-2	dry/cond.
CTI, test liquid A	–	IEC 60112	–
Core Products			

Footnotes

- ¹⁾ For undyed product, unless otherwise indicated in the product designation.
²⁾ Empirical values for parts repeatedly exposed to this temperature for several hours at a time over a period of years, provided that shaping and processing were in accord with the material.
³⁾ N = not broken
⁴⁾ Test box with central gating, base dimensions (107 · 47 · 1.5) mm.
⁵⁾ + = Passed

B3EG3	B3EG5	B3WG5	B3EG6	B3WG6	B3PG6	B3HG7
PA6-GF15	PA6-GF25	PA6-GF25	PA6-GF30	PA6-GF30	PA6-GF30	PA6-GF35
1,230	1,320	1,320	1,360	1,360	1,360	1,403
140	140	140	140	140	156	155
7.7 - 8.3	6.8 - 7.4	6.8 - 7.4	6.3 - 6.9	6.3 - 6.9	6.3 - 6.9	5.9 - 6.5
2.30 - 2.90	2.10 - 2.50	2.10 - 2.50	1.90 - 2.30	1.90 - 2.30	2.0 - 2.4	1.80 - 2.20
220	220	220	220	220	220	220
55, 275 (5)	45, 275 (5)	40, 275 (5)	35, 275 (5)	30, 275 (5)	18, 275 (5)	22, 275 (5)
270 - 290	270 - 290	270 - 290	270 - 290	270 - 290	270 - 290	270 - 290
80 - 90	80 - 90	80 - 90	80 - 90	80 - 90	80 - 90	80 - 90
0.45, 280 (80)	0.35, 280 (80)	0.35, 280 (80)	0.30, 280 (80)	0.30, 280 (80)	0.30, 280 (80)	–
0.55 (0.75)	0.35 (0.70)	0.30 (0.70)	0.25 (0.70)	0.30 (0.75)	0.25 (0.56)	0.25 (0.80)
HB	HB	HB	HB	HB	–	–
+	+	+	+	+	–	–
5,800/3,500	8,000/5,500	8,000/5,000	9,500/6,200	9,500/6,200	10,000/5,500	10,500/6,300
130*/70*	160*/105*	160*/105*	185*/115*	185*/115*	190/110	180*/115*
3.5*/15*	3.5*/8.5*	3.5*/8.5*	3.5*/8*	3.5*/8*	4.0/4.7	4.7*/10.7*
2,100	3,000	3,000	–	–	–	–
5,200/2,500	7,400/4,200	7,400/4,200	8,600/5,000	8,600/5,000	8,900/5,100	–
180/100	220/150	220/150	270/180	270/180	280/165	–
50/105	80/105	80/105	95/110	95/110	100/105	105/115
45/–	75/–	70/–	80/–	80/85	80/80	99/100
8/20	12/25	12/25	15/30	15/30	14.9/26.0	15/20
7/–	10/–	10/–	11/–	11/10.2	10.9/10.9	9.7/10.7
190	210	200	210	210	200	205
215	220	220	220	220	220	220
200	200	200	200	200	200	200
135 (165)	135 (165)	145 (175)	135 (165)	145 (175)	–	–
0.34	0.35	0.35	0.36	0.36	–	0.36
1,600	1,500	1,500	1,500	1,500	–	1,400
33 (112)	27 (110)	27 (110)	22 (106)	25 (102)	–	20 (101)
3.8/7	3.8/7	3.8/7	3.8/6.8	3.8/6.8	–	–
250/2,400	250/2,400	250/2,400	230/2,200	230/2,200	–	–
10 ¹³ /10 ¹⁰	10 ¹³ /10 ¹⁰	10 ¹³ /10 ¹⁰	10 ¹³ /10 ¹⁰	10 ¹³ /10 ¹⁰	10 ¹⁴ /10 ¹⁰	–
*/10 ¹⁰	*/10 ¹⁰	*/10 ¹⁰	*/10 ¹⁰	*/10 ¹⁰	*/10 ¹²	–
550	575	450	575	450	450	–
UN, SW00564	UN, SW00564	UN, SW00564	UN, SW00564	UN, SW00564, GPX SW23238	SW23346	SW00565

Glass-fiber reinforced injection-molding grade, e.g. for household appliances.

Glass-fiber reinforced injection-molding grade for industrial articles and electrical insulating parts.

Glass-fiber reinforced and heat aging resistant injection-molding grade, e.g. for fan impellers.

Glass-fiber reinforced injection-molding grade for technical articles as well as for electric insulating parts, e.g. Sensors.

Glass-fiber reinforced and heat aging resistant injection-molding grade, e.g. for vehicle intake manifolds and pedals.

Low metal and low halide, glass-fiber reinforced injection-molding grade with excellent heat aging resistance for technical articles primarily from the areas of charge air duct and exhaust gas recirculation with the highest requirements for bursting pressure resistance under long-term stress.

Glass fibre reinforced and heat ageing resistant injection-molding grade with excellent flowability used e.g. for plastic parts in automotive or E&E industry. The product offers a high purity regarding ionic and halogen containing compounds minimizing potential corrosion processes to protect sensitive electronic components.

Ultramid® – Injection-molding grades without flame retardants

Reinforced Ultramid® B grades

Values at 23°C ¹⁾	Unit	Test specification	Condition
Features			
Polymer abbreviation	–	–	–
Density	kg/m ³	ISO 1183	–
Viscosity number (0.005 g/ml sulphuric acid)	cm ³ /g	ISO 307	–
Water absorption, equilibrium in water at 23 °C	%	ISO 62	–
Moisture absorption, equilibrium in standard cond. 23 °C/50 % r.h.	%	ISO 62	–
Processing			
Melting temperature, DSC	°C	ISO 11357-1/-3	–
Melt volume-flow rate MVR, test temperature (load)	cm ³ /10 min, °C (kg)	ISO 1133	–
Melt temperature injection moulding	°C	–	–
Mold temperature injection moulding	°C	–	–
Molding shrinkage, test box, d = 1.5 mm, T _M (T _W) ⁴⁾	%, °C (°C)	–	–
Molding shrinkage parallel (perpendicular)	%	ISO 294-4	–
Flammability			
Flammability acc. to UL 94, d = 1.6 mm	class	IEC 60695-11-10	–
Testing of materials for automobile interior, burning rate ≤ 100 mm/min, d ≥ 1 mm ⁵⁾	–	ISO 3795, FMVSS 302	–
Mechanical properties			
Tensile modulus of elasticity	MPa	ISO 527-1/-2	dry/cond.
Yield stress (v = 50 mm/min), (Stress at break (v = 5 mm/min))*	MPa	ISO 527-1/-2	dry/cond.
Yield strain (v = 50 mm/min), (Strain at break (v = 5 mm/min))*	%	ISO 527-1/-2	dry/cond.
Tensile creep modulus, 1,000 h, elongation ≤ 0.5 %, +23 °C	MPa	ISO 899-1	cond.
Flexural modulus	MPa	ISO 178	dry/cond.
Flexural stress at max. force	MPa	ISO 178	dry/cond.
Charpy unnotched impact strength, 23 °C ³⁾	kJ/m ²	ISO 179/1eU	dry/cond.
Charpy unnotched impact strength, -30 °C	kJ/m ²	ISO 179/1eU	dry/cond.
Charpy notched impact strength, 23 °C ³⁾	kJ/m ²	ISO 179/1eA	dry/cond.
Charpy notched impact strength, -30 °C	kJ/m ²	ISO 179/1eA	dry/cond.
Thermal properties			
Heat distortion temperature under 1.8 MPa load (HDT A)	°C	ISO 75-1/-2	–
Heat distortion temperature under 0.45 MPa load (HDT B)	°C	ISO 75-1/-2	–
Max. service temperature, up to a few hours ²⁾	°C	–	–
Temperature index for 50 % loss of tensile strength after 20,000 h (5,000 h)	°C	IEC 60216	–
Thermal conductivity, 23 °C	W/(m · K)	DIN 52612-1	–
Specific heat capacity, 23 °C	J/(kg · K)	–	–
Coeff. of linear therm. expansion 23 °C - 55 °C, parallel (perpendicular)	10 ⁻⁶ /K	ISO 11359-1/-2	–
Electrical properties			
Dielectric constant at 1 MHz	–	IEC 62631-2-1	dry/cond.
Dissipation factor at 1 MHz	10 ⁻⁴	IEC 62631-2-1	dry/cond.
Volume resistivity	Ω · m	IEC 62631-3-1	dry/cond.
Surface resistivity	Ω	IEC 62631-3-2	dry/cond.
CTI, test liquid A	–	IEC 60112	–
Core Products			

Footnotes

- ¹⁾ For undyed product, unless otherwise indicated in the product designation.
- ²⁾ Empirical values for parts repeatedly exposed to this temperature for several hours at a time over a period of years, provided that shaping and processing were in accord with the material.
- ³⁾ N = not broken
- ⁴⁾ Test box with central gating, base dimensions (107 · 47 · 1.5) mm.
- ⁵⁾ + = Passed

B3WG7	B3G8	B3WG10	B3WG12 HSP	B3ZG3	B3ZG6
PA6-GF35	PA6-GF40	PA6-GF50	PA6-GF60	PA6-I GF15	PA6-I GF30
1,410	1,430	1,550	1,720	1,220	1,330
140	140	135	105	160	160
5.9-6.5	5.4-6	4.5-5.1	4.1-5.2	7.2-7.8	5.9-6.5
1.80-2.20	1.60-2.00	1.30-1.70	1.2-1.6	2.10-2.70	1.80-2.20
220	220	220	220	220	220
45, 275 (5)	25, 275 (5)	10, 275 (5)	22, 275 (5)	35, 275 (5)	20, 275 (5)
270-290	270-290	280-300	280-310	270-290	270-290
80-90	80-90	80-90	90-120	80-90	80-90
0.30, 280 (80)	–	0.3, 300 (80)	0.25, 300 (100)	0.5, 280 (80)	0.30, 280 (80)
0.25 (0.75)	0.25 (0.80)	0.20 (0.70)	0.30 (0.55)	0.60 (0.70)	0.30 (0.70)
HB	–	HB	–	HB	HB
+	+	+	+	+	+
11,000/7,200	13,000/8,200	16,000/11,000	21,000/14,000	5,100/2,900	8,650/4,850
195*/130*	205*/135*	235*/160*	247*/165*	100*/60*	138*/78*
3.5*/7*	2.8*/4.6*	3*/5.5*	2.2*/3.9*	5.3*/18*	3.6*/5.1*
4,550	3,300	7,400	–	–	3,000
10,000/6,300	10,500/7,400	15,000/9,000	20,700/14,400	4,500/2,500	7,400/4,700
280/200	290/205	320/240	400/270	150/80	220/130
100/105	90/105	100/110	99/97	75/110	95/110
90/93	85/–	90/98	85/95	55/–	90/101
14/22	14/22	22/30	14.6/17.6	16/30	20/35
10/11	11/–	16/13.3	13.9/13.3	7/–	15/9.7
215	215	215	210	180	200
220	220	220	220	200	220
200	200	200	200	180	180
145 (175)	– (–)	145 (175)	–	–	–
0.36	0.36	0.38	–	0.34	0.35
1,400	1,400	1,300	–	–	–
20 (101)	16 (110)	15 (73)	28 (29)	35 (129)	21 (116)
3.9/6.2	4/6	4.2/6.1	–	3.7/6.2	3.8/6.8
210/1,900	140/1,300	140/1,400	–	250/2,000	200/2,000
10 ¹³ /10 ¹⁰	10 ¹³ /10 ¹⁰	10 ¹³ /10 ¹⁰	–	10 ¹³ /10 ¹⁰	10 ¹³ /10 ¹⁰
*/10 ¹⁰	*/10 ¹⁰	*/10 ¹⁰	–	*/10 ¹⁰	*/10 ¹⁰
450	550	450	–	550	550
UN, SW00564	SW00564	SW00564, SW23346	SW23228	UN, SW30564	UN, SW30564

Glass-fiber reinforced and heat aging resistant injection-molding grade, e.g. for vehicle intake manifolds and pedals.

Glass-fiber reinforced injection-molding grade for pedals or pedal modules.

Glass-fiber reinforced and heat aging resistant injection-molding grade for technical parts with very high stiffness.

Glass fibre reinforced and heat ageing resistant injection moulding grade with high flowability and excellent surface quality for structural parts with very high stiffness requirements.

Impact-modified and glass-fiber reinforced injection-molding grade, e.g. for automotive cable conduits.

Impact-modified and glass-fiber reinforced injection-molding grade for technical articles of very high stiffness and toughness, e.g. for vehicle airbag housings and housings for power tools.

Ultramid® – Injection-molding grades without flame retardants

Reinforced Ultramid® B grades

Values at 23°C ¹⁾	Unit	Test specification	Condition
Features			
Polymer abbreviation	–	–	–
Density	kg/m ³	ISO 1183	–
Viscosity number (0.005 g/ml sulphuric acid)	cm ³ /g	ISO 307	–
Water absorption, equilibrium in water at 23 °C	%	ISO 62	–
Moisture absorption, equilibrium in standard cond. 23 °C/50 % r.h.	%	ISO 62	–
Processing			
Melting temperature, DSC	°C	ISO 11357-1/-3	–
Melt volume-flow rate MVR, test temperature (load)	cm ³ /10 min, °C (kg)	ISO 1133	–
Melt temperature injection moulding	°C	–	–
Mold temperature injection moulding	°C	–	–
Molding shrinkage, test box, d = 1.5 mm, T _M (T _W) ⁴⁾	%, °C (°C)	–	–
Molding shrinkage parallel (perpendicular)	%	ISO 294-4	–
Flammability			
Flammability acc. to UL 94, d = 1.6 mm	class	IEC 60695-11-10	–
Testing of materials for automobile interior, burning rate ≤ 100 mm/min, d ≥ 1 mm ⁵⁾	–	ISO 3795, FMVSS 302	–
Mechanical properties			
Tensile modulus of elasticity	MPa	ISO 527-1/-2	dry/cond.
Yield stress (v = 50 mm/min), (Stress at break (v = 5 mm/min))*	MPa	ISO 527-1/-2	dry/cond.
Yield strain (v = 50 mm/min), (Strain at break (v = 5 mm/min))*	%	ISO 527-1/-2	dry/cond.
Tensile creep modulus, 1,000 h, elongation ≤ 0.5 %, +23 °C	MPa	ISO 899-1	cond.
Flexural modulus	MPa	ISO 178	dry/cond.
Flexural stress at max. force	MPa	ISO 178	dry/cond.
Charpy unnotched impact strength, 23 °C ³⁾	kJ/m ²	ISO 179/1eU	dry/cond.
Charpy unnotched impact strength, -30 °C	kJ/m ²	ISO 179/1eU	dry/cond.
Charpy notched impact strength, 23 °C ³⁾	kJ/m ²	ISO 179/1eA	dry/cond.
Charpy notched impact strength, -30 °C	kJ/m ²	ISO 179/1eA	dry/cond.
Thermal properties			
Heat distortion temperature under 1.8 MPa load (HDT A)	°C	ISO 75-1/-2	–
Heat distortion temperature under 0.45 MPa load (HDT B)	°C	ISO 75-1/-2	–
Max. service temperature, up to a few hours ²⁾	°C	–	–
Temperature index for 50 % loss of tensile strength after 20,000 h (5,000 h)	°C	IEC 60216	–
Thermal conductivity, 23 °C	W/(m · K)	DIN 52612-1	–
Specific heat capacity, 23 °C	J/(kg · K)	–	–
Coeff. of linear therm. expansion 23 °C - 55 °C, parallel (perpendicular)	10 ⁻⁶ /K	ISO 11359-1/-2	–
Electrical properties			
Dielectric constant at 1 MHz	–	IEC 62631-2-1	dry/cond.
Dissipation factor at 1 MHz	10 ⁻⁴	IEC 62631-2-1	dry/cond.
Volume resistivity	Ω · m	IEC 62631-3-1	dry/cond.
Surface resistivity	Ω	IEC 62631-3-2	dry/cond.
CTI, test liquid A	–	IEC 60112	–
Core Products			

Footnotes

- ¹⁾ For undyed product, unless otherwise indicated in the product designation.
²⁾ Empirical values for parts repeatedly exposed to this temperature for several hours at a time over a period of years, provided that shaping and processing were in accord with the material.
³⁾ N = not broken
⁴⁾ Test box with central gating, base dimensions (107 · 47 · 1.5) mm.
⁵⁾ + = Passed

B3ZG8	B3ZM5	B3GK24	B3K6	B3M6	B3WGM24 HP	B3GM35
PA6-I GF40	PA6-I-MD25	PA6-(GF10+GB20)	PA6-GB30	PA6-M30	PA6-(GF10+M20)	PA6-(GF15+M25)
1,400	1,300	1,340	1,350	1,360	1,370	1,480
–	145	140	150	145	123	160
4.7 - 5.3	7.2 - 7.4	6.3 - 6.9	6 - 6.5	5.9 - 6.5	6.9 - 7.5	5.7
1.40 - 1.80	2.0 - 2.4	1.90 - 2.30	1.8	2.20 - 2.60	2.10 - 2.50	1.7
220	220	220	220	220	220	220
10, 275 (5)	80, 275 (5)	50, 275 (5)	–	50, 275 (5)	90, 275 (5)	45, 275 (5)
270 - 290	270 - 290	270 - 290	270 - 290	270 - 290	270 - 290	270 - 290
80 - 90	80 - 90	80 - 90	80 - 90	80 - 90	80 - 90	80 - 90
0.35, 280 (80)	0.85, 280 (80)	0.45, 280 (80)	0.7, 280 (80)	0.75, 280 (80)	0.20, 280 (80)	0.4, 280 (80)
0.30 (0.65)	1.15 (1.15)	0.60 (0.80)	1.15 (1.10)	1.30 (1.10)	0.40 (0.60)	0.40 (0.85)
HB	–	HB	–	HB	–	–
+	–	+	+	+	+	+
11,600/6,700	4,100/1,300	6,000/3,000	4,000/1,200	4,600/1,700	8,400/4,000	8,000/5,000
165*/115*	65/45	110*/60*	55*/35*	75*/45*	115*/55*	120*/65*
4.9/9.5*	4.0/20.0	3.5*/15*	10*/>50*	12*/45*	2.7*/9.8*	3*/12*
–	–	2,000	–	800	2,300	1,850
9,500/6,100	3,700/1,400	–	3,800/1,100	4,000/1,400	8,200/3,800	–
250/155	115/50	175/100	–	125/50	175/90	190/110
110/130	>250/N	40/90	35/150	190/N	45/50	50/–
105/110	225/215	39/–	25/–	100/–	40/40	50/–
24/40	7.2/18.0	5/11	3.5/8.5	9/18	8/15	8/–
15/13.7	4.1/3.8	5/–	2.5/–	5/–	5.5/4	6/–
205	72	200	65	70	190	200
220	179	215	170	195	215	215
180	–	200	180	180	180	180
–	–	100 (-)	–	100 (-)	–	–
0.36	–	0.34	–	0.31	–	0.38
–	–	1,400	–	1,400	1,300	1,300
18 (125)	81 (219)	48 (79)	–	75 (91)	39 (86)	33 (76)
4/5.3	–	3.9/4.6	3.5/6.2	3.5/6.2	3.9/6.2	3.9/6.2
200/1,300	–	200/700	200/2,000	200/2,000	200/2,000	200/2,000
10 ¹³ /10 ¹⁰	–	10 ¹³ /10 ¹⁰	10 ¹³ /10 ¹⁰	10 ¹³ /10 ¹⁰	10 ¹³ /10 ¹⁰	10 ¹³ /10 ¹⁰
*/10 ¹⁰	–	*/10 ¹⁰	–	*/10 ¹⁰	*/10 ¹⁰	*/10 ¹⁰
550	–	425	500	450	–	400
SW20560, SW23346	UN	UN, SW00564	UN, SW802	SW30564, GRQ94 22319	SW23210	SW30564
Impact-modified and glass-fiber reinforced injection-molding grade for technical articles of very high stiffness and toughness, e.g., for vehicle airbag housings and suitcase shells.	Mineral reinforced injection-molding grade that combines good impact strength with good dimensional stability and is suitable, for example, for components subject to mechanical stress in the furniture fittings sector. Due to its property profile, it can also be considered as a substitute for unreinforced PA6.6.	Combined glass-fiber and glass-bead reinforced injection-molding grade for technical articles of very good dimensional stability, e.g. electronic housings	Injection moulding grade filled with glass spheres for technical parts with good dimensional stability, such as electronic casing.	Mineral-filled injection-molding grade for highly impact-resistant technical articles with very good dimensional stability.	Mineral-filled and glass-fiber reinforced injection-molding grade with outstanding flowability for technical parts with medium rigidity and high dimensional stability, e.g. for automotive engine covers or housings.	Mineral-filled and glass-fiber reinforced injection-molding grade for industrial articles having medium rigidity and high dimensional stability, e.g. for covers or handles.

Ultramid® – Injection-molding grades without flame retardants

Ultramid® Endure grades

Values at 23°C ¹⁾	Unit	Test specification	Condition
Features			
Polymer abbreviation	–	–	–
Density	kg/m ³	ISO 1183	–
Viscosity number (0.005 g/ml sulphuric acid)	cm ³ /g	ISO 307	–
Water absorption, equilibrium in water at 23 °C	%	ISO 62	–
Moisture absorption, equilibrium in standard cond. 23 °C/50 % r.h.	%	ISO 62	–
Processing			
Melting temperature, DSC	°C	ISO 11357-1/-3	–
Melt volume-flow rate MVR, test temperature (load)	cm ³ /10 min, °C (kg)	ISO 1133	–
Melt temperature injection moulding	°C	–	–
Mold temperature injection moulding	°C	–	–
Molding shrinkage, test box, d = 1.5 mm, T _M (T _w) ⁴⁾	%, °C (°C)	–	–
Molding shrinkage parallel (perpendicular)	%	ISO 294-4	–
Flammability			
Flammability acc. to UL 94, d = 1.6 mm	class	IEC 60695-11-10	–
Testing of materials for automobile interior, burning rate ≤ 100 mm/min, d ≥ 1 mm ⁵⁾	–	ISO 3795, FMVSS 302	–
Mechanical properties			
Tensile modulus of elasticity	MPa	ISO 527-1/-2	dry/cond.
Yield stress (v = 50 mm/min), (Stress at break (v = 5 mm/min))*	MPa	ISO 527-1/-2	dry/cond.
Yield strain (v = 50 mm/min), (Strain at break (v = 5 mm/min))*	%	ISO 527-1/-2	dry/cond.
Tensile creep modulus, 1,000 h, elongation ≤ 0.5 %, +23 °C	MPa	ISO 899-1	cond.
Flexural modulus	MPa	ISO 178	dry/cond.
Flexural stress at max. force	MPa	ISO 178	dry/cond.
Charpy unnotched impact strength, 23 °C ³⁾	kJ/m ²	ISO 179/1eU	dry/cond.
Charpy unnotched impact strength, -30 °C	kJ/m ²	ISO 179/1eU	dry/cond.
Charpy notched impact strength, 23 °C ³⁾	kJ/m ²	ISO 179/1eA	dry/cond.
Charpy notched impact strength, -30 °C	kJ/m ²	ISO 179/1eA	dry/cond.
Thermal properties			
Heat distortion temperature under 1.8 MPa load (HDT A)	°C	ISO 75-1/-2	–
Heat distortion temperature under 0.45 MPa load (HDT B)	°C	ISO 75-1/-2	–
Max. service temperature, up to a few hours ²⁾	°C	–	–
Temperature index for 50 % loss of tensile strength after 20,000 h (5,000 h)	°C	IEC 60216	–
Thermal conductivity, 23 °C	W/(m · K)	DIN 52612-1	–
Specific heat capacity, 23 °C	J/(kg · K)	–	–
Coeff. of linear therm. expansion 23 °C - 55 °C, parallel (perpendicular)	10 ⁻⁶ /K	ISO 11359-1/-2	–
Electrical properties			
Dielectric constant at 1 MHz	–	IEC 62631-2-1	dry/cond.
Dissipation factor at 1 MHz	10 ⁻⁴	IEC 62631-2-1	dry/cond.
Volume resistivity	Ω · m	IEC 62631-3-1	dry/cond.
Surface resistivity	Ω	IEC 62631-3-2	dry/cond.
CTI, test liquid A	–	IEC 60112	–
Core Products			

Footnotes

¹⁾ For undyed product, unless otherwise indicated in the product designation.

²⁾ Empirical values for parts repeatedly exposed to this temperature for several hours at a time over a period of years, provided that shaping and processing were in accord with the material.

³⁾ N = not broken

⁴⁾ Test box with central gating, base dimensions (107 · 47 · 1.5) mm.

⁵⁾ + = Passed

Endure D5G3 BM	Endure D3G7	Endure D3G10
PA66-GF15	PA66-GF35	PA66-GF50
1,230	1,433	1,606
–	137	130
–	5.8	3.7 - 4.3
1.85	1.85	1.00 - 1.40
17, 290 (10)	260	260
–	38, 275 (5)	34, 275 (5)
–	280 - 300	280 - 300
60 - 90	0.35, 290 (80)	80 - 90
–	–	0.22, 300 (80)
1.19 (0.87)	0.30 (0.87)	0.30 (0.77)
–	–	–
+	+	+
5,500/3,270	11,300/7,600	17,200/11,900
115*/72.8*	200*/130*	240/165
5*/15.8*	2.9*/5.1*	2.4/3.6
2,450	4,800	–
4,730/2,750	10,600/7,400	16,000/11,200
182/101	300/200	365/250
84/109	70/70	95/90
48/51	60/60	85/75
10/15	10.2/13.4	13.8/15.4
4.4/5.2	10.7/13.9	13.4/13.1
220	240	248
250	260	259
240	240	240
–	–	–
–	–	–
–	–	–
33 (110)	16 (100)	–
–	–	–
–	–	–
–	30 ¹² /30 ⁸	–
–	*/50 ¹³	–
–	225	–
SW20560	SW20560, SW23325	SW20560

Glass fiber reinforced blow moulding grade with good sagging behaviour, ideal swelling and excellent heat ageing resistance up to at least 220 °C for tubes in the charge air duct mainly.

Glass fiber reinforced injection moulding grade with high stiffness, very good flowability, and excellent heat ageing resistance up to at least 220 °C for technical articles.

Glass fiber reinforced injection moulding grade with high stiffness, very good flowability, and excellent heat ageing resistance up to at least 220 °C for technical articles.

Ultramid® – Injection-molding grades without flame retardants

Ultramid® S Balance grades

Values at 23°C ¹⁾	Unit	Test specification	Condition
Features			
Polymer abbreviation	–	–	–
Density	kg/m ³	ISO 1183	–
Viscosity number (0.005 g/ml sulphuric acid)	cm ³ /g	ISO 307	–
Water absorption, equilibrium in water at 23 °C	%	ISO 62	–
Moisture absorption, equilibrium in standard cond. 23 °C/50 % r.h.	%	ISO 62	–
Processing			
Melting temperature, DSC	°C	ISO 11357-1/-3	–
Melt volume-flow rate MVR, test temperature (load)	cm ³ /10 min, °C (kg)	ISO 1133	–
Melt temperature injection moulding	°C	–	–
Mold temperature injection moulding	°C	–	–
Molding shrinkage, test box, d = 1.5 mm, T _M (T _w) ⁴⁾	%, °C (°C)	–	–
Molding shrinkage parallel (perpendicular)	%	ISO 294-4	–
Flammability			
Flammability acc. to UL 94, d = 1.6 mm	class	IEC 60695-11-10	–
Testing of materials for automobile interior, burning rate ≤ 100 mm/min, d ≥ 1 mm ⁵⁾	–	ISO 3795, FMVSS 302	–
Mechanical properties			
Tensile modulus of elasticity	MPa	ISO 527-1/-2	dry/cond.
Yield stress (v = 50 mm/min), (Stress at break (v = 5 mm/min))*	MPa	ISO 527-1/-2	dry/cond.
Yield strain (v = 50 mm/min), (Strain at break (v = 5 mm/min))*	%	ISO 527-1/-2	dry/cond.
Tensile creep modulus, 1,000 h, elongation ≤ 0.5 %, +23 °C	MPa	ISO 899-1	cond.
Flexural modulus	MPa	ISO 178	dry/cond.
Flexural stress at max. force	MPa	ISO 178	dry/cond.
Charpy unnotched impact strength, 23 °C ³⁾	kJ/m ²	ISO 179/1eU	dry/cond.
Charpy unnotched impact strength, -30 °C	kJ/m ²	ISO 179/1eU	dry/cond.
Charpy notched impact strength, 23 °C ³⁾	kJ/m ²	ISO 179/1eA	dry/cond.
Charpy notched impact strength, -30 °C	kJ/m ²	ISO 179/1eA	dry/cond.
Thermal properties			
Heat distortion temperature under 1.8 MPa load (HDT A)	°C	ISO 75-1/-2	–
Heat distortion temperature under 0.45 MPa load (HDT B)	°C	ISO 75-1/-2	–
Max. service temperature, up to a few hours ²⁾	°C	–	–
Temperature index for 50 % loss of tensile strength after 20,000 h (5,000 h)	°C	IEC 60216	–
Thermal conductivity, 23 °C	W/(m · K)	DIN 52612-1	–
Specific heat capacity, 23 °C	J/(kg · K)	–	–
Coeff. of linear therm. expansion 23 °C - 55 °C, parallel (perpendicular)	10 ⁻⁶ /K	ISO 11359-1/-2	–
Electrical properties			
Dielectric constant at 1 MHz	–	IEC 62631-2-1	dry/cond.
Dissipation factor at 1 MHz	10 ⁻⁴	IEC 62631-2-1	dry/cond.
Volume resistivity	Ω · m	IEC 62631-3-1	dry/cond.
Surface resistivity	Ω	IEC 62631-3-2	dry/cond.
CTI, test liquid A	–	IEC 60112	–
Core Products			

Footnotes

¹⁾ For undyed product, unless otherwise indicated in the product designation.

²⁾ Empirical values for parts repeatedly exposed to this temperature for several hours at a time over a period of years, provided that shaping and processing were in accord with the material.

³⁾ N = not broken

⁴⁾ Test box with central gating, base dimensions (107 · 47 · 1.5) mm.

⁵⁾ + = Passed

S3W Balance	S3Z4	S3Z5	S3WG6 Balance
PA610	PA610-I	PA610-I	PA610-GF30
1,079	1,024	1,021	1,310
155	–	–	150
3.77	2.99	2.85	2 - 2.6
1.52	–	–	0.80 - 1.20
220	220	220	220
84, 275 (5)	39, 275 (5)	12, 275 (5)	23, 275 (5)
250 - 270	250 - 270	250 - 270	270 - 290
40 - 60	60 - 80	60 - 80	80 - 90
–	0.84, 260 (30)	0.97, 260 (30)	–
1.40 (1.60)	1.48 (1.21)	2.29 (1.17)	0.40 (1.00)
–	–	–	–
2,440/1,600	1,500/870	1,350/790	8,200/6,400
67/55	40/30	35/30	150/110
4.3/17	4.6/17.6	5.1/18	4/6
–	–	–	–
2,200/1,500	–	–	7,500/6,000
90/56	–	–	225/175
N/N	N/N	N/N	85/80
N/N	N/N	N/N	80/–
3.8/3.9	75/98	84/103	13/13
4.5/3.5	18/18	20/20	8/–
60	–	–	200
155	–	–	220
–	–	–	–
–	–	–	–
–	–	–	–
2,400	–	–	–
95 (109)	–	–	–
–	–	–	–
–	–	–	–
40 ¹² /80 ⁹	–	–	–
* /20 ¹⁴	–	–	–
600	–	–	550
UN	UN	UN	SW00564

Heat stabilized long-chain polyamide for injection-molding, low water absorption, especially high hydrolysis, chemical and stress cracking resistance.

Injection moulding grade with good melt flowability, very high impact, moulded parts with particular demands made on the impact resistance and the notched impact resistance also at lower temperatures (e.g. ski boots and sport shoes).

Injection moulding grade with good melt flowability, very high impact, moulded parts with particular demands made on the impact resistance and the notched impact resistance also at lower temperatures (e.g. ski boots and sport shoes).

Glass-fiber reinforced injection-molding grade, low water absorption, especially high hydrolysis, chemical and stress cracking resistance, e.g. for quick connectors.

Ultramid® – Injection-molding grades without flame retardants

Ultramid® Structure

Values at 23°C ¹⁾	Unit	Test specification	Condition
Features			
Polymer abbreviation	–	–	–
Density	kg/m ³	ISO 1183	–
Viscosity number (0.005 g/ml sulphuric acid)	cm ³ /g	ISO 307	–
Water absorption, equilibrium in water at 23 °C	%	ISO 62	–
Moisture absorption, equilibrium in standard cond. 23 °C/50 % r.h.	%	ISO 62	–
Processing			
Melting temperature, DSC	°C	ISO 11357-1/-3	–
Melt volume-flow rate MVR, test temperature (load)	cm ³ /10 min, °C (kg)	ISO 1133	–
Melt temperature injection moulding	°C	–	–
Mold temperature injection moulding	°C	–	–
Molding shrinkage, test box, d = 1.5 mm, T _M (T _w) ⁴⁾	%, °C (°C)	–	–
Molding shrinkage parallel (perpendicular)	%	ISO 294-4	–
Flammability			
Flammability acc. to UL 94, d = 1.6 mm	class	IEC 60695-11-10	–
Testing of materials for automobile interior, burning rate ≤ 100 mm/min, d ≥ 1 mm ⁵⁾	–	ISO 3795, FMVSS 302	–
Mechanical properties			
Tensile modulus of elasticity	MPa	ISO 527-1/-2	dry/cond.
Yield stress (v = 50 mm/min), (Stress at break (v = 5 mm/min))*	MPa	ISO 527-1/-2	dry/cond.
Yield strain (v = 50 mm/min), (Strain at break (v = 5 mm/min))*	%	ISO 527-1/-2	dry/cond.
Tensile creep modulus, 1,000 h, elongation ≤ 0.5 %, +23 °C	MPa	ISO 899-1	cond.
Flexural modulus	MPa	ISO 178	dry/cond.
Flexural stress at max. force	MPa	ISO 178	dry/cond.
Charpy unnotched impact strength, 23 °C ³⁾	kJ/m ²	ISO 179/1eU	dry/cond.
Charpy unnotched impact strength, -30 °C	kJ/m ²	ISO 179/1eU	dry/cond.
Charpy notched impact strength, 23 °C ³⁾	kJ/m ²	ISO 179/1eA	dry/cond.
Charpy notched impact strength, -30 °C	kJ/m ²	ISO 179/1eA	dry/cond.
Thermal properties			
Heat distortion temperature under 1.8 MPa load (HDT A)	°C	ISO 75-1/-2	–
Heat distortion temperature under 0.45 MPa load (HDT B)	°C	ISO 75-1/-2	–
Max. service temperature, up to a few hours ²⁾	°C	–	–
Temperature index for 50 % loss of tensile strength after 20,000 h (5,000 h)	°C	IEC 60216	–
Thermal conductivity, 23 °C	W/(m · K)	DIN 52612-1	–
Specific heat capacity, 23 °C	J/(kg · K)	–	–
Coeff. of linear therm. expansion 23 °C - 55 °C, parallel (perpendicular)	10 ⁻⁶ /K	ISO 11359-1/-2	–
Electrical properties			
Dielectric constant at 1 MHz	–	IEC 62631-2-1	dry/cond.
Dissipation factor at 1 MHz	10 ⁻⁴	IEC 62631-2-1	dry/cond.
Volume resistivity	Ω · m	IEC 62631-3-1	dry/cond.
Surface resistivity	Ω	IEC 62631-3-2	dry/cond.
CTI, test liquid A	–	IEC 60112	–
Core Products			

Footnotes

¹⁾ For undyed product, unless otherwise indicated in the product designation.

²⁾ Empirical values for parts repeatedly exposed to this temperature for several hours at a time over a period of years, provided that shaping and processing were in accord with the material.

³⁾ N = not broken

⁴⁾ Test box with central gating, base dimensions (107 · 47 · 1.5) mm.

⁵⁾ + = Passed

Structure A3WG10 LFX	Structure B3WG10 LFX
PA66-GCond.50	PA6-GCond.50
1,585	1,567
120	125
4.44	4.74
	1.4
260	220
–	–
290-310	280-300
80-90	80-90
0.39, 300 (100)	0.22, 300 (100)
0.42 (0.73)	0.32 (0.52)
–	–
–	–
17,400/13,100	16,900/11,000
260*/190*	255*/160*
2.8*/2.3*	2.3*/2.5*
10,100	10,400
16,000/12,800	15,700/11,000
380/300	395/260
90/95	95/85
80/85	80/85
30/30	30/30
35/35	38/31
260	219
–	–
240	200
–	–
–	–
–	–
17.5 (70)	–
3.8/6.6	4.2/6.1
150/3,000	140/1,400
10 ¹³ /10 ¹⁰	10 ¹³ /10 ¹⁰
*/10 ¹⁰	*/10 ¹⁰
450	450
SW23215	SW23215

Long glass fiber reinforcement for high stiffness at elevated temperatures. Significantly lower creep tendency, especially at elevated temperatures and very good fatigue strength. Significantly improved impact strength, especially at low temperatures such as -30 °C.

Long glass fiber reinforcement for high stiffness at elevated temperatures. Significantly lower creep tendency, especially at elevated temperatures and very good fatigue strength. Significantly improved impact strength, especially at low temperatures such as -30 °C.

Ultramid® – Injection-molding grades without flame retardants

Unreinforced Ultramid® T grades, reinforced Ultramid® T grades

Values at 23°C ¹⁾	Unit	Test specification	Condition
Features			
Polymer abbreviation	–	–	–
Density	kg/m ³	ISO 1183	–
Viscosity number (0.005 g/ml sulphuric acid)	cm ³ /g	ISO 307	–
Water absorption, equilibrium in water at 23 °C	%	ISO 62	–
Moisture absorption, equilibrium in standard cond. 23 °C/50 % r.h.	%	ISO 62	–
Processing			
Melting temperature, DSC	°C	ISO 11357-1/-3	–
Melt volume-flow rate MVR, test temperature (load)	cm ³ /10 min, °C (kg)	ISO 1133	–
Melt temperature injection moulding	°C	–	–
Mold temperature injection moulding	°C	–	–
Molding shrinkage, test box, d = 1.5 mm, T _M (T _w) ⁴⁾	%, °C (°C)	–	–
Molding shrinkage parallel (perpendicular)	%	ISO 294-4	–
Flammability			
Flammability acc. to UL 94, d = 1.6 mm	class	IEC 60695-11-10	–
Testing of materials for automobile interior, burning rate ≤ 100 mm/min, d ≥ 1 mm ⁵⁾	–	ISO 3795, FMVSS 302	–
Mechanical properties			
Tensile modulus of elasticity	MPa	ISO 527-1/-2	dry/cond.
Yield stress (v = 50 mm/min), (Stress at break (v = 5 mm/min))*	MPa	ISO 527-1/-2	dry/cond.
Yield strain (v = 50 mm/min), (Strain at break (v = 5 mm/min))*	%	ISO 527-1/-2	dry/cond.
Tensile creep modulus, 1,000 h, elongation ≤ 0.5 %, +23 °C	MPa	ISO 899-1	cond.
Flexural modulus	MPa	ISO 178	dry/cond.
Flexural stress at max. force	MPa	ISO 178	dry/cond.
Charpy unnotched impact strength, 23 °C ³⁾	kJ/m ²	ISO 179/1eU	dry/cond.
Charpy unnotched impact strength, -30 °C	kJ/m ²	ISO 179/1eU	dry/cond.
Charpy notched impact strength, 23 °C ³⁾	kJ/m ²	ISO 179/1eA	dry/cond.
Charpy notched impact strength, -30 °C	kJ/m ²	ISO 179/1eA	dry/cond.
Thermal properties			
Heat distortion temperature under 1.8 MPa load (HDT A)	°C	ISO 75-1/-2	–
Heat distortion temperature under 0.45 MPa load (HDT B)	°C	ISO 75-1/-2	–
Max. service temperature, up to a few hours ²⁾	°C	–	–
Temperature index for 50 % loss of tensile strength after 20,000 h (5,000 h)	°C	IEC 60216	–
Thermal conductivity, 23 °C	W/(m · K)	DIN 52612-1	–
Specific heat capacity, 23 °C	J/(kg · K)	–	–
Coeff. of linear therm. expansion 23 °C - 55 °C, parallel (perpendicular)	10 ⁻⁶ /K	ISO 11359-1/-2	–
Electrical properties			
Dielectric constant at 1 MHz	–	IEC 62631-2-1	dry/cond.
Dissipation factor at 1 MHz	10 ⁻⁴	IEC 62631-2-1	dry/cond.
Volume resistivity	Ω · m	IEC 62631-3-1	dry/cond.
Surface resistivity	Ω	IEC 62631-3-2	dry/cond.
CTI, test liquid A	–	IEC 60112	–
Core Products			

Footnotes

¹⁾ For undyed product, unless otherwise indicated in the product designation.

²⁾ Empirical values for parts repeatedly exposed to this temperature for several hours at a time over a period of years, provided that shaping and processing were in accord with the material.

³⁾ N = not broken

⁴⁾ Test box with central gating, base dimensions (107 · 47 · 1.5) mm.

⁵⁾ + = Passed

T KR 4350	T KR 4355 G5	T KR 4355 G7	T KR 4355 G10	T KR 4357 G6
PA6T/6	PA6T/6-GF25	PA6T/6-GF35	PA6T/6-GF50	PA6T/6-I GF30
1,160	1,350	1,430	–	1,370
130	130	130	130	130
6.5 - 7.5	5 - 6	4.3 - 5.3	3.5 - 4.5	4 - 5
1.60 - 2.00	1.10 - 1.50	0.80 - 1.20	0.40 - 0.80	0.60 - 1.00
295	295	295	285	295
30, 325 (5)	–	–	–	–
310 - 330	310 - 330	310 - 330	310 - 330	310 - 330
70 - 100	80 - 120	80 - 120	80 - 120	80 - 120
0.6, 315 (90)	0.4, 320 (100)	0.35, 320 (100)	0.13, 320 (100)	0.35, 320 (100)
0.85 (1.10)	0.45 (1.00)	0.30 (1.00)	0.20 (0.60)	0.40 (1.00)
HB	HB	HB	–	HB
+	+	+	–	+
3,100/3,100	9,000/9,000	12,000/12,000	18,000/–	9,300/9,000
80/70	185*/170*	210*/200*	260*/–	165*/145*
5/–	3*/–	3*/–	2.8*/–	3.5*/–
2,300	6,500	8,700	–	6,500
2,900/–	7,300/–	–	–	–
–	–	–	–	–
140/–	80/–	100/–	100/–	95/–
130/–	–	–	–	–
8/–	8/–	14.5/–	14/–	17/–
6/–	–	–	–	–
95	245	245	245	240
–	–	–	–	–
250	270	270	260	270
110 (130)	135 (160)	135 (160)	–	130 (160)
0.23	0.25	0.28	–	0.25
1,500	1,400	1,300	–	1,400
70	25 (55)	15 (55)	18 (55)	25 (55)
4/4	4.3/4.5	4.2/4.4	4.7/4.8	4.3/4.5
300/400	300/400	200/300	200/300	300/400
10 ¹³ /10 ¹²	10 ¹³ /10 ¹²	10 ¹³ /10 ¹²	10 ¹⁵ /10 ¹⁴	10 ¹³ /10 ¹²
*/10 ¹³	*/10 ¹³	*/10 ¹³	*/>10 ¹⁶	*/10 ¹³
600	600	600	–	600
SW00464	SW00564	SW00564	SW23215	SW00564

For injection-molding and extrusion, exhibiting high toughness, strength and stiffness, high melting point (295°C [563°F]). The mechanical properties remain constant after moisture absorption up to a temperature of 60°C [140°F].

Glass-fiber reinforced product for injection-molding; high toughness, strength and stiffness, high melting point (295°C [563°F]). The mechanical properties remain constant after moisture absorption up to a temperature of 60°C [140°F], for instance, for brush collars (electric motors).

Glass-fiber reinforced product for injection-molding; high toughness, strength and stiffness, high melting point (295°C [563°F]). The mechanical properties remain constant after moisture absorption up to a temperature of 60°C [140°F], for instance, for automotive valve housings.

Glass-fiber reinforced product for injection-molding; high toughness and rigidity; high melting point (285°C); mechanical properties remain constant up to 60°C after moisture absorption; suitable e. g. for valve housings.

Glass-fiber reinforced, impact-modified product for injection-molding; high toughness, strength and stiffness, high melting point (295°C [563°F]). The mechanical properties remain constant after moisture absorption up to a temperature of 60°C [140°F], for instance, for automotive plug-in connectors.

Ultramid® – Injection-molding grades without flame retardants

Ultramid® Advanced unreinforced, Ultramid® Advanced reinforced

Values at 23°C ¹⁾	Unit	Test specification	Condition
Features			
Polymer abbreviation	–	–	–
Density	kg/m ³	ISO 1183	–
Viscosity number (0.005 g/ml sulphuric acid)	cm ³ /g	ISO 307	–
Water absorption, equilibrium in water at 23°C	%	ISO 62	–
Moisture absorption, equilibrium in standard cond. 23°C/50% r.h.	%	ISO 62	–
Processing			
Melting temperature, DSC	°C	ISO 11357-1/-3	–
Melt volume-flow rate MVR, test temperature (load)	cm ³ /10 min, °C (kg)	ISO 1133	–
Melt temperature injection moulding	°C	–	–
Mold temperature injection moulding	°C	–	–
Molding shrinkage, test box, d = 1.5 mm, T _M (T _w) ⁴⁾	%, °C (°C)	–	–
Molding shrinkage parallel (perpendicular)	%	ISO 294-4	–
Flammability			
Flammability acc. to UL 94, d = 1.6 mm	class	IEC 60695-11-10	–
Testing of materials for automobile interior, burning rate ≤ 100 mm/min, d ≥ 1 mm ⁵⁾	–	ISO 3795, FMVSS 302	–
Mechanical properties			
Tensile modulus of elasticity	MPa	ISO 527-1/-2	dry/cond.
Yield stress (v = 50 mm/min), (Stress at break (v = 5 mm/min))*	MPa	ISO 527-1/-2	dry/cond.
Yield strain (v = 50 mm/min), (Strain at break (v = 5 mm/min))*	%	ISO 527-1/-2	dry/cond.
Tensile creep modulus, 1,000 h, elongation ≤ 0.5 %, +23°C	MPa	ISO 899-1	cond.
Flexural modulus	MPa	ISO 178	dry/cond.
Flexural stress at max. force	MPa	ISO 178	dry/cond.
Charpy unnotched impact strength, 23°C ³⁾	kJ/m ²	ISO 179/1eU	dry/cond.
Charpy unnotched impact strength, -30°C	kJ/m ²	ISO 179/1eU	dry/cond.
Charpy notched impact strength, 23°C ³⁾	kJ/m ²	ISO 179/1eA	dry/cond.
Charpy notched impact strength, -30°C	kJ/m ²	ISO 179/1eA	dry/cond.
Thermal properties			
Heat distortion temperature under 1.8 MPa load (HDT A)	°C	ISO 75-1/-2	–
Heat distortion temperature under 0.45 MPa load (HDT B)	°C	ISO 75-1/-2	–
Max. service temperature, up to a few hours ²⁾	°C	–	–
Temperature index for 50% loss of tensile strength after 20,000 h (5,000 h)	°C	IEC 60216	–
Thermal conductivity, 23°C	W/(m·K)	DIN 52612-1	–
Specific heat capacity, 23°C	J/(kg·K)	–	–
Coeff. of linear therm. expansion 23°C-55°C, parallel (perpendicular)	10 ⁻⁶ /K	ISO 11359-1/-2	–
Electrical properties			
Dielectric constant at 1 MHz	–	IEC 62631-2-1	dry/cond.
Dissipation factor at 1 MHz	10 ⁻⁴	IEC 62631-2-1	dry/cond.
Volume resistivity	Ω·m	IEC 62631-3-1	dry/cond.
Surface resistivity	Ω	IEC 62631-3-2	dry/cond.
CTI, test liquid A	–	IEC 60112	–
Core Products			

Footnotes

¹⁾ For undyed product, unless otherwise indicated in the product designation.

²⁾ Empirical values for parts repeatedly exposed to this temperature for several hours at a time over a period of years, provided that shaping and processing were in accord with the material.

³⁾ N = not broken

⁴⁾ Test box with central gating, base dimensions (107·47·1.5) mm.

⁵⁾ + = Passed

Advanced N4H	Advanced N3HG6	Advanced N4WG7	Advanced T1000HG7
PA9T	PA9T-GF30	PA9T-GF35	PA6T/6I-GF35
1,130	1,370	1,420	1,485
125	100	120	–
2.5	2	–	–
1.2	–	–	–
300	300	300	320
–	–	–	–
320-340	320-340	320-340	345-360
100-160	100-160	100-160	150-170
–	–	–	–
1.74 (1.82)	0.47 (0.98)	0.48 (0.88)	0.40 (0.93)
–	–	–	–
–	–	–	–
2,600/2,600	10,500/–	11,500/11,500	14,000/14,000
90/90, 65*/70*	190*/–	215*/195*	220*/210*
> 5/> 5, 7*/7*	2.5*/–	2.9*/2.6*	2*/1.9*
–	–	–	–
2,600/2,700	–	–	13,000/13,000
115/125	–	–	300/290
N/50	65/–	85/70	70/–
130/40	60/–	75/65	70/–
6/6	9/–	9/8	8/–
8/6	9/–	9/8	8/–
130	270	270	> 280
–	–	–	–
–	–	–	–
–	–	–	–
–	–	–	–
–	–	–	–
–	–	–	–
3.3/3.3	–	3.9/3.9	–
165/260	–	135/195	–
>10 ¹⁶ / ^{>} 10 ¹⁶	–	>10 ¹⁴ / ^{>} 10 ¹⁴	>10 ¹⁵ / ^{>} 10 ¹⁵
* />10 ¹⁴	–	* />10 ¹⁵	* />10 ¹⁵
550	–	500	600
UN, LS SW23593	UN, LS SW23260	LS SW23260	UN, LS SW23593
Partially aromatic polyphthalamide for injection molding. High, constant stiffness and strength over a temperature range of -40 °C to over 80 °C as well as resistance against aggressive media	Partially aromatic polyphthalamide for injection molding. High, constant stiffness and strength over a temperature range of -40 °C to over 80 °C as well as resistance against aggressive media.	Partially aromatic polyphthalamide for injection molding and extrusion. Very low water absorption, excellent chemical resistance and good mechanics at high temperatures in conditioned state. Ultramid® Advanced N3HG6 with good flowability, for E&E applications, JEDEC class 1.	Partially aromatic polyphthalamide for injection molding. Very low water absorption, excellent chemical resistance and good mechanics at high temperatures in conditioned state. Ultramid® Advanced N4H has an outstanding dimensional stability and resistance, even against wear and abrasion.

Ultramid® – Injection-molding grades without flame retardants

Ultramid® Advanced unreinforced, Ultramid® Advanced reinforced

Values at 23°C ¹⁾	Unit	Test specification	Condition
Features			
Polymer abbreviation	–	–	–
Density	kg/m ³	ISO 1183	–
Viscosity number (0.005 g/ml sulphuric acid)	cm ³ /g	ISO 307	–
Water absorption, equilibrium in water at 23 °C	%	ISO 62	–
Moisture absorption, equilibrium in standard cond. 23 °C/50 % r.h.	%	ISO 62	–
Processing			
Melting temperature, DSC	°C	ISO 11357-1/-3	–
Melt volume-flow rate MVR, test temperature (load)	cm ³ /10 min, °C (kg)	ISO 1133	–
Melt temperature injection moulding	°C	–	–
Mold temperature injection moulding	°C	–	–
Molding shrinkage, test box, d = 1.5 mm, T _M (T _w) ⁴⁾	%, °C (°C)	–	–
Molding shrinkage parallel (perpendicular)	%	ISO 294-4	–
Flammability			
Flammability acc. to UL 94, d = 1.6 mm	class	IEC 60695-11-10	–
Testing of materials for automobile interior, burning rate ≤ 100 mm/min, d ≥ 1 mm ⁵⁾	–	ISO 3795, FMVSS 302	–
Mechanical properties			
Tensile modulus of elasticity	MPa	ISO 527-1/-2	dry/cond.
Yield stress (v = 50 mm/min), (Stress at break (v = 5 mm/min))*	MPa	ISO 527-1/-2	dry/cond.
Yield strain (v = 50 mm/min), (Strain at break (v = 5 mm/min))*	%	ISO 527-1/-2	dry/cond.
Tensile creep modulus, 1,000 h, elongation ≤ 0.5 %, +23 °C	MPa	ISO 899-1	cond.
Flexural modulus	MPa	ISO 178	dry/cond.
Flexural stress at max. force	MPa	ISO 178	dry/cond.
Charpy unnotched impact strength, 23 °C ³⁾	kJ/m ²	ISO 179/1eU	dry/cond.
Charpy unnotched impact strength, -30 °C	kJ/m ²	ISO 179/1eU	dry/cond.
Charpy notched impact strength, 23 °C ³⁾	kJ/m ²	ISO 179/1eA	dry/cond.
Charpy notched impact strength, -30 °C	kJ/m ²	ISO 179/1eA	dry/cond.
Thermal properties			
Heat distortion temperature under 1.8 MPa load (HDT A)	°C	ISO 75-1/-2	–
Heat distortion temperature under 0.45 MPa load (HDT B)	°C	ISO 75-1/-2	–
Max. service temperature, up to a few hours ²⁾	°C	–	–
Temperature index for 50 % loss of tensile strength after 20,000 h (5,000 h)	°C	IEC 60216	–
Thermal conductivity, 23 °C	W/(m · K)	DIN 52612-1	–
Specific heat capacity, 23 °C	J/(kg · K)	–	–
Coeff. of linear therm. expansion 23 °C - 55 °C, parallel (perpendicular)	10 ⁻⁶ /K	ISO 11359-1/-2	–
Electrical properties			
Dielectric constant at 1 MHz	–	IEC 62631-2-1	dry/cond.
Dissipation factor at 1 MHz	10 ⁻⁴	IEC 62631-2-1	dry/cond.
Volume resistivity	Ω · m	IEC 62631-3-1	dry/cond.
Surface resistivity	Ω	IEC 62631-3-2	dry/cond.
CTI, test liquid A	–	IEC 60112	–
Core Products			

Footnotes

- ¹⁾ For undyed product, unless otherwise indicated in the product designation.
²⁾ Empirical values for parts repeatedly exposed to this temperature for several hours at a time over a period of years, provided that shaping and processing were in accord with the material.
³⁾ N = not broken
⁴⁾ Test box with central gating, base dimensions (107 · 47 · 1.5) mm.
⁵⁾ + = Passed

Advanced T1000HG10	Advanced T2300EG6	Advanced T2300HG6
PA6T/6I-GF50	PA6T/66-GF30	PA6T/66-GF30
1,642	1,390	1,390
–	125	130
–	4.2	4.2
–	1.3	1.3
320	310	310
–	–	–
345-360	320-340	320-340
150-170	120-160	120-160
–	–	–
0.50 (0.87)	0.52 (1.13)	0.50 (1.10)
–	–	HB
–	–	–
19,000/19,000	10,200/10,200	10,400/10,200
260*/250*	190/160	190/160
2*/2*	2.8/3.2	2.8/3.2
–	–	–
–	9,200/9,200	9,300/9,300
–	340/280	270/240
80/75	55/50	65/55
75/75	85/75	90/75
12/10	7.3/6.9	7.5/7.1
12/11	8.7/9.0	8.5/8.1
> 280	> 280	> 280
–	–	–
–	250	250
–	–	125 (155)
–	–	–
–	–	–
–	–	22 (72)
–	–	3.8/4.1
–	–	170/270
>10 ¹⁶ / ^{>} 10 ¹⁵	–	10 ¹⁵ / ^{>} 10 ¹⁵
* />10 ¹⁵	–	* />10 ¹⁵
550	–	600
UN, LS SW23593	UN	LS SW23346

Partially aromatic polyphthalamide for injection molding. Very low water absorption, excellent chemical resistance and good mechanics at high temperatures in conditioned state. Ultramid® Advanced N4WG7 with high toughness and outstanding heat resistance, for Automotive applications.

Polyphthalamide providing good E&E performance with a high melting point, low water absorption, good mechanical properties at high temperatures and good chemical resistance.

Polyphthalamide providing good E&E performance with a high melting point, low water absorption, good mechanical properties at high temperatures and good chemical resistance.

Ultramid® – Injection-molding grades with flame retardants

Unreinforced grades

Values at 23°C ¹⁾	Unit	Test specification	Condition
Features			
Polymer abbreviation	–	–	–
Density	kg/m ³	ISO 1183	–
Water absorption, saturation in water at 23 °C	%	similar ISO 62	–
Moisture absorption, equilibrium in standard cond. atmo. 23 °C/50 % r.h.	%	similar ISO 62	–
Flammability			
Flammability acc. to UL 94 (thickness)	class (mm)	UL-94, IEC 60695	–
Electrical properties			
UL (f1) proven for outdoor use: color code, min. thickness	color, mm	UL 746C	–
UL 746 C Fire/ignition performance (UL94+HAI+HWI), min. thickness	mm	UL 746C	–
GWFI (thickness)	°C (mm)	IEC 60695-2-12	–
GWIT (thickness)	°C (mm)	IEC 60695-2-13	–
Oxygen Index	%	ISO 4589-1/-2	–
Testing of materials for automobile interior, Burning rate ≤ 100mm/min, d ≤ 1 mm ⁵⁾	–	ISO 3795, FMVSS 302	–
Railway: Hazard level acc. to requ. sets R22 and R23	class	EN 45545-2	–
Electrical properties			
Relative permittivity at 1 MHz	–	IEC 62631-2-1	dry/cond.
Dissipation factor at 1 MHz	10 ⁻⁴	IEC 62631-2-1	dry/cond.
Volume resistivity	Ω · m	IEC 62631-3-1	dry/cond.
Surface resistivity	Ω	IEC 62631-3-2	dry/cond.
CTI, solution A	–	IEC 60112	–
Thermal properties			
Deflection temperature HDT A (1.80 MPa)	°C	ISO 75-1/-2	–
Deflection temperature HDT B (0.45 MPa)	°C	ISO 75-1/-2	–
Max. service temperature, up to a few hours ²⁾	°C	–	–
Temperature index for 50 % loss of tensile strength after 20,000 h (5,000 h)	°C	IEC 60216	–
RTI "dielectric strength" at 1.5 mm thickness	°C	UL 746B	–
Thermal conductivity, 23 °C	W / (m · K)	DIN 52612-1	–
Specific heat capacity, 23 °C	J / (kg · K)	–	–
Coeff. of linear therm. expansion 23 °C - 55 °C (parallel) (perpendicular)	10 ⁻⁵ / K	ISO 11359-1/-2	–
Mechanical properties			
Tensile modulus of elasticity	MPa	ISO 527-1/-2	dry/cond.
Yield stress (v=50 mm/min), (Stress at break (v=5 mm/min))*	MPa	ISO 527-1/-2	dry/cond.
Yield strain (v=50 mm/min), (Strain at break (v=5 mm/min))*	%	ISO 527-1/-2	dry/cond.
Tensile creep modulus, 1,000 h	MPa	ISO 899-1	cond.
Flexural modulus	MPa	ISO 178	dry/cond.
Flexural stress at max. force	MPa	ISO 178	dry/cond.
Charpy unnotched impact strength, 23 °C ³⁾	kJ/m ²	ISO 179/1eU	dry/cond.
Charpy unnotched impact strength, -30 °C ³⁾	kJ/m ²	ISO 179/1eU	dry/cond.
Charpy notched impact strength, 23 °C	kJ/m ²	ISO 179/1eA	dry/cond.
Charpy notched impact strength, -30 °C	kJ/m ²	ISO 179/1eA	dry/cond.
Processing			
Melting temperature, DSC	°C	ISO 11357-1/-3	–
Melt volume-flow rate MVR, test temperature (load)	cm ³ /10 min, °C (kg)	ISO 1133	–
Melt temperature injection moulding	°C	–	–
Mould temperature injection moulding	°C	–	–
Molding shrinkage, test box, d = 1.5 mm, T _M (T _w) ⁴⁾	%, °C (°C)	–	–
Molding shrinkage parallel (perpendicular)	%	ISO 294-4	–

Footnotes

¹⁾ For undyed product, unless otherwise indicated in the product designation.

²⁾ Empirical values for parts repeatedly exposed to this temperature for several hours at a time over a period of years, provided that shaping and processing were in accord with the material.

³⁾ N = not broken

⁴⁾ Test box with central gating, base dimensions (107 · 47 · 1.5) mm.

⁵⁾ + = Passed

A3K R01	A3U32	C3U	B3S R03
PA66	(PA66+PA6) FR (30)	PA66/6 FR (30)	PA6
1,130	1,180	1,160	1,130
8-9	7-8	8-9	9-10
2.50-3.10	2.20-2.80	2.60-3.20	2.60-3.40
V-2 (0.4)	V-0 (0.25)	V-0 (0.4)	V-2 (0.75)
BK, 1.5			BK, RD, YL, 0.75
3	0.25	0.4	–
960 (1)	960 (0.8)	960 (0.4)	850 (≤ 1.5)
775 (≤ 1.5)	775 (≤ 1.5)	775 (≤ 1.5)	775 (≤ 1.5)
28	34	34	–
+	+	+	+
	HL3 (0.4-2mm)	(R24: HL3)	
3.2/5	3.4/4.2	3.6/6	3.3/7
250/2,000	200/930	200/3,000	300/3,000
$10^{13}/10^{10}$	$>10^{14}/>10^{11}$	$10^{13}/10^9$	$10^{13}/10^9$
$-/10^{13}$	$*/>10^{13}$	$-/10^{12}$	$-/10^{12}$
600	600	600	600
75	80	70	65
220	215	210	180
200	–	200	180
101 (118)	–	107 (123)	87 (97)
125	130	120	130
0.33	0.33	0.33	0.33
1,700	1,500	1,700	1,700
98 (–)	60-80 (60-90)	68 (81)	102 (–)
3,100/1,100	3,700/1,800	3,500/1,500	3,500/1,200
85/50	75/50	75/45	90/45
5/20	3.5/15	4/20	4/20
700	–	890	1,100
2,900/–	3,600/1,800	3,000/–	3,000/–
–	120/55	–	–
N/N	55/120	80/N	250/N
–	45/–	–	200/–
5/20	3/4	6/35	4/50
4/–	–	4/–	3/–
260	260	243	220
120, 275 (5)	–	160, 275 (5)	190, 275 (5)
280-300	270-280	250-270	250-270
60-80	60-80	60-80	40-60
0.85/290/60	0.9, 270 (80)	0.8/270/60	0.55/260/60
1.50 (1.80)	1.50 (1.70)	1.25 (1.27)	0.87 (1.00)

An easy flowing injection moulding grade for fast processing. Used for highly stressed technical parts, such as bearings, gear wheels and electrically insulating parts such as terminals and cable connectors.

Injection moulding grade with improved flame retardance (free from halogens), used e.g. for electrical insulating parts with very small wall thicknesses.

An injection moulding grade with improved flame retardance (free from halogens), used e.g. for impact resistant electrical insulating parts such as contact bases and plug connector strips.

An easy flowing, finely crystalline injection moulding grade for very fast processing. Parts produced include thin-walled technical parts (eg housing, fittings, grips, small parts and fixing clamps).

Ultramid® – Injection-molding grades with flame retardants

Reinforced grades

Values at 23°C ¹⁾	Unit	Test specification	Condition
Features			
Polymer abbreviation	–	–	–
Density	kg/m ³	ISO 1183	–
Water absorption, saturation in water at 23 °C	%	similar ISO 62	–
Moisture absorption, equilibrium in standard cond. atmo. 23 °C/50 % r.h.	%	similar ISO 62	–
Flammability			
Flammability acc. to UL 94 (thickness)	class (mm)	UL-94, IEC 60695	–
Electrical properties			
UL (f1) proven for outdoor use: color code, min. thickness	color, mm	UL 746C	–
UL 746 C Fire/ignition performance (UL94+HAI+HWI), min. thickness	mm	UL 746C	–
GWFI (thickness)	°C (mm)	IEC 60695-2-12	–
GWIT (thickness)	°C (mm)	IEC 60695-2-13	–
Oxygen Index	%	ISO 4589-1/-2	–
Testing of materials for automobile interior, Burning rate ≤ 100mm/min, d ≤ 1 mm ⁵⁾	–	ISO 3795, FMVSS 302	–
Railway: Hazard level acc. to requ. sets R22 and R23	class	EN 45545-2	–
Electrical properties			
Relative permittivity at 1 MHz	–	IEC 62631-2-1	dry/cond.
Dissipation factor at 1 MHz	10 ⁻⁴	IEC 62631-2-1	dry/cond.
Volume resistivity	Ω · m	IEC 62631-3-1	dry/cond.
Surface resistivity	Ω	IEC 62631-3-2	dry/cond.
CTI, solution A	–	IEC 60112	–
Thermal properties			
Deflection temperature HDT A (1.80 MPa)	°C	ISO 75-1/-2	–
Deflection temperature HDT B (0.45 MPa)	°C	ISO 75-1/-2	–
Max. service temperature, up to a few hours ²⁾	°C	–	–
Temperature index for 50 % loss of tensile strength after 20,000 h (5,000 h)	°C	IEC 60216	–
RTI "dielectric strength" at 1.5 mm thickness	°C	UL 746B	–
Thermal conductivity, 23 °C	W / (m · K)	DIN 52612-1	–
Specific heat capacity, 23 °C	J / (kg · K)	–	–
Coeff. of linear therm. expansion 23 °C - 55 °C (parallel) (perpendicular)	10 ⁻⁵ / K	ISO 11359-1/-2	–
Mechanical properties			
Tensile modulus of elasticity	MPa	ISO 527-1/-2	dry/cond.
Yield stress (v=50 mm/min), (Stress at break (v=5 mm/min))*	MPa	ISO 527-1/-2	dry/cond.
Yield strain (v=50 mm/min), (Strain at break (v=5 mm/min))*	%	ISO 527-1/-2	dry/cond.
Tensile creep modulus, 1,000 h	MPa	ISO 899-1	cond.
Flexural modulus	MPa	ISO 178	dry/cond.
Flexural stress at max. force	MPa	ISO 178	dry/cond.
Charpy unnotched impact strength, 23 °C ³⁾	kJ/m ²	ISO 179/1eU	dry/cond.
Charpy unnotched impact strength, -30 °C ³⁾	kJ/m ²	ISO 179/1eU	dry/cond.
Charpy notched impact strength, 23 °C	kJ/m ²	ISO 179/1eA	dry/cond.
Charpy notched impact strength, -30 °C	kJ/m ²	ISO 179/1eA	dry/cond.
Processing			
Melting temperature, DSC	°C	ISO 11357-1/-3	–
Melt volume-flow rate MVR, test temperature (load)	cm ³ /10 min, °C (kg)	ISO 1133	–
Melt temperature injection moulding	°C	–	–
Mould temperature injection moulding	°C	–	–
Molding shrinkage, test box, d = 1.5 mm, T _M (T _w) ⁴⁾	%, °C (°C)	–	–
Molding shrinkage parallel (perpendicular)	%	ISO 294-4	–

Footnotes

- ¹⁾ For undyed product, unless otherwise indicated in the product designation.
- ²⁾ Empirical values for parts repeatedly exposed to this temperature for several hours at a time over a period of years, provided that shaping and processing were in accord with the material.
- ³⁾ N=not broken
- ⁴⁾ Test box with central gating, base dimensions (107 · 47 · 1.5) mm.
- ⁵⁾ +=Passed

A3UG5	A3U42G6	A3U44G6 DC	A3X2G5	A3XZG5	A3X2G7
PA66-GF25 FR (40)	PA66-Blend GF30 FR (40)	PA66-Blend GF30 FR (40)	PA66-GF25 FR (52)	PA66-I GF25 FR (52)	PA66-GF35 FR (52)
1,390	1,450	1,430	1,370	1,320	1,450
4 - 4.6	4.8 - 5.2		5.7 - 6.3	4.7 - 5.3	4.4 - 5
1.10 - 1.50	1.60 - 1.80		1.40 - 1.70	1.00 - 1.40	1.00 - 1.40
V-0 (0.75)	V-0 (0.4) 5VA (1.6)	V-0 (0.4)	HB (0.4) V-0 (0.81) 5VA (3)	V-0 (1.5) 5VA (2.3)	HB (0.4) V-0 (0.75) 5VA (1.5)
BK, GY, 0.75	BK, GY, 0.75		BK, 1.6	BK, 0.75	BK, 0.75
0.75	0.4	–	0.6	1.5	0.75
960 (0.75)	960 (1)	960 (0.8)	960 (0.8)	–	960 (1)
775 (≥ 2)	–	–	–	–	–
32	37	–	27	28	27
+	+	+	+	+	+
HL3 (0.8 - 6 mm)	HL3 (1 - 3 mm)				
3.8/4.6	3.9/4.1	–	3.7/5	3.8/4	3.6/5
170/1,000	150/290	–	200/1,000	200/300	200/2,000
10 ¹³ /10 ¹⁰	>10 ¹³ /10 ¹⁰	–	10 ¹³ /10 ¹⁰	10 ¹³ /10 ¹⁰	10 ¹³ /10 ¹⁰
–/10 ¹³	–/10 ¹³	–	–/10 ¹³	–/10 ¹³	–/10 ¹³
600	600	600	550	575	600
245	230	235	240	240	240
260	250	–	250	250	250
–	–	–	220	180	220
130 (155)	140 (166)	–	139 (157)	–	140 (157)
120	150	–	120	120	115
0.34	–	–	0.33	0.33	0.34
1,300	–	–	1,500	–	1,400
28 (72)	22 (79)	–	30 (102)	36 (127)	20 (95)
9,500/6,100	11,000/7,500	11,000/10,900	8,000/6,000	6,500/4,500	11,000/8,500
145*/90*	145*/95*	155*/120*	140*/100*	105*/70*	160*/120*
3*/5*	3*/5*	3*/3.2*	3*/4.5*	6*/11*	3*/4*
–	–	–	3,500	2,000	4,250
9,500/6,100	11,000/7,500	10,500/9,500	7,100/–	5,500/–	9,200/–
230/160	230/160	240/195	–	115/100	–
65/65	70/75	70/65	65/70	90/100	70/70
63/–	55/60	70/60	60/65	85/80	65/–
7.5/9	8/11	8.5/9	13/17	25/30	14/18
–	7/7	–	–	–	10/–
260	260	260	260	260	260
25, 275 (5)	15, 275 (5)	10, 275 (5)	30, 275 (5)	3, 300 (10)	25, 275 (5)
280 - 300	280 - 300	280 - 300	280 - 300	280 - 300	280 - 300
80 - 90	80 - 90	80 - 90	60 - 90	80 - 90	80 - 90
0.4/290/80	0.35/290/80	–	0.50/290/80	0.55/290/80	0.45/290/80
0.40 (1.20)	0.30 (0.90)	0.25 (0.75)	0.45 (1.15)	–	0.35 (1.15)
Without halogenes and red phosphorus a flame retarded glass fiber reinforced injection moulding grade; light in colour with outstanding mechanical and electrical properties.	Without halogenes flame retarded glass fiber reinforced injection moulding grade; light colorable; outstanding mechanical and electrical properties.	Halogen-free, flame retardant, glass fiber reinforced injection-molding grade; light colorable; excellent mechanical and electrical properties.	Glass fibre reinforced injection moulding grade with improved flame retardance based on red phosphorus, giving outstanding mechanical and electrical properties for components requiring high stiffness.	An impact-modified, glass fibre reinforced injection moulding grade with improved flame retardance based on red phosphorus; for components requiring high stiffness and enhanced toughness. (e.g. PV-connectors an PV-junction boxes).	Glass fibre fibre reinforced injection moulding grade with improved flame retardance. Flame retardant based on red phosphorus; giving outstanding electrical properties and very high stiffness and strength.

Ultramid® – Injection-molding grades with flame retardants

Reinforced grades

Values at 23°C ¹⁾	Unit	Test specification	Condition
Features			
Polymer abbreviation	–	–	–
Density	kg/m ³	ISO 1183	–
Water absorption, saturation in water at 23 °C	%	similar ISO 62	–
Moisture absorption, equilibrium in standard cond. atmo. 23 °C/50 % r.h.	%	similar ISO 62	–
Flammability			
Flammability acc. to UL 94 (thickness)	class (mm)	UL-94, IEC 60695	–
UL (f1) proven for outdoor use: color code, min. thickness	color, mm	UL 746C	–
UL 746 C Fire/ignition performance (UL94+HAI+HWI), min. thickness	mm	UL 746C	–
GWFI (thickness)	°C (mm)	IEC 60695-2-12	–
GWIT (thickness)	°C (mm)	IEC 60695-2-13	–
Oxygen Index	%	ISO 4589-1/-2	–
Testing of materials for automobile interior, Burning rate ≤ 100mm/min, d ≤ 1 mm ⁵⁾	–	ISO 3795, FMVSS 302	–
Railway: Hazard level acc. to requ. sets R22 and R23	class	EN 45545-2	–
Electrical properties			
Relative permittivity at 1 MHz	–	IEC 62631-2-1	dry/cond.
Dissipation factor at 1 MHz	10 ⁻⁴	IEC 62631-2-1	dry/cond.
Volume resistivity	Ω · m	IEC 62631-3-1	dry/cond.
Surface resistivity	Ω	IEC 62631-3-2	dry/cond.
CTI, solution A	–	IEC 60112	–
Thermal properties			
Deflection temperature HDT A (1.80 MPa)	°C	ISO 75-1/-2	–
Deflection temperature HDT B (0.45 MPa)	°C	ISO 75-1/-2	–
Max. service temperature, up to a few hours ²⁾	°C	–	–
Temperature index for 50 % loss of tensile strength after 20,000 h (5,000 h)	°C	IEC 60216	–
RTI "dielectric strength" at 1.5 mm thickness	°C	UL 746B	–
Thermal conductivity, 23 °C	W / (m · K)	DIN 52612-1	–
Specific heat capacity, 23 °C	J / (kg · K)	–	–
Coeff. of linear therm. expansion 23 °C - 55 °C (parallel) (perpendicular)	10 ⁻⁵ / K	ISO 11359-1/-2	–
Mechanical properties			
Tensile modulus of elasticity	MPa	ISO 527-1/-2	dry/cond.
Yield stress (v=50 mm/min), (Stress at break (v=5 mm/min))*	MPa	ISO 527-1/-2	dry/cond.
Yield strain (v=50 mm/min), (Strain at break (v=5 mm/min))*	%	ISO 527-1/-2	dry/cond.
Tensile creep modulus, 1,000 h	MPa	ISO 899-1	cond.
Flexural modulus	MPa	ISO 178	dry/cond.
Flexural stress at max. force	MPa	ISO 178	dry/cond.
Charpy unnotched impact strength, 23 °C ³⁾	kJ/m ²	ISO 179/1eU	dry/cond.
Charpy unnotched impact strength, -30 °C ³⁾	kJ/m ²	ISO 179/1eU	dry/cond.
Charpy notched impact strength, 23 °C	kJ/m ²	ISO 179/1eA	dry/cond.
Charpy notched impact strength, -30 °C	kJ/m ²	ISO 179/1eA	dry/cond.
Processing			
Melting temperature, DSC	°C	ISO 11357-1/-3	–
Melt volume-flow rate MVR, test temperature (load)	cm ³ /10 min, °C (kg)	ISO 1133	–
Melt temperature injection moulding	°C	–	–
Mould temperature injection moulding	°C	–	–
Molding shrinkage, test box, d = 1.5 mm, T _M (T _w) ⁴⁾	%, °C (°C)	–	–
Molding shrinkage parallel (perpendicular)	%	ISO 294-4	–

Footnotes

¹⁾ For undyed product, unless otherwise indicated in the product designation.

²⁾ Empirical values for parts repeatedly exposed to this temperature for several hours at a time over a period of years, provided that shaping and processing were in accord with the material.

³⁾ N = not broken

⁴⁾ Test box with central gating, base dimensions (107 · 47 · 1.5) mm.

⁵⁾ + = Passed

A3X2G10	A3XZC3 ESD	B3UG4	B3U30G6	B3U42G6	B3U50G6	B3UGM210
PA66-GF50 FR (52)	PA66-I CF15 FR(52)	PA6-GF20 FR (30)	PA6-GF30 FR (30)	PA6 GF30 FR(40)	PA6-GF30 FR (53)	PA6-(GF10+M50) FR (61)
1,600	1,190	1,310	1,440	1,450	1,500	1,670
3.7 - 4.3		6.6 - 7.2	5.3 - 5.9	5.1 - 5.3	5.5 - 5.7	4.1 - 4.7
0.70 - 1.10		2.00 - 2.40	1.50 - 2.00	1.6 - 1.9	1.50 - 1.70	1.00 - 1.40
V-2 (0.4) V-0 (1.5)	V-0 (1.5)	V-2 (0.71)	HB (0.4) V-2 (0.75)	V-0 (0.4)	V-0 (0.75) 5VA (1.5)	V-2 (0.75) V-0 (1.5)
	BK, 0.75	BK, 0.71			BK, GY; 1.5	
0.75	0.75	1.5	0.75	0.4	0.4	0.75
960 (1)	960 (1)	960 (1)	960 (1)	960 (0.75)	960 (≥ 0.75)	960 (1)
-	-	-	-	-	800 (≥ 0.75)	-
27	-	31	-	-	30	52
+	+	+	+	+	+	+
		HL2 (1 - 3mm)			HL2 (0.8 - 3mm)	
3.6/5	-	3.8/-	4/4.8	3.8/4.4	4.1/4.7	4.5/5
200/-	-	150/-	200/1,000	170/640	170/730	150/500
10 ¹³ /10 ¹⁰	-	10 ¹³ /10 ⁹	10 ¹³ /10 ⁹	10 ¹⁴ /10 ¹¹	10 ¹³ /10 ⁹	10 ¹³ /10 ⁹
-/10 ¹³	-/10 ⁶	-/10 ¹²	-/10 ¹⁴	-/10 ¹⁴	-/10 ¹²	-/10 ¹²
600	-	550	475	600	450	600
250	235	170	180	206	210	195
250	255	210	210	-	220	215
220	-	200	-	-	-	200
125 (145)	132 (169)	160 (185)	-	141 (168)	165 (180)	149 (167)
115	-	140	140	130	150	130
0.35	-	0.4	0.28	-	-	1
1,300	-	1,300	1,200	-	-	1,400
17 (66)	14 (130)	41 (86)	40 (88)	24 (82)	23 (82)	35 (54)
16,000/12,000	10,000/5,800	6,000/3,000	7,700/3,500	11,000/7,700	12,000/8,300	11,000/6,500
180*/130*	130*/85*	95*/50*	90*/45*	140*/95*	170*/115*	110*/80*
2*/3*	3.7*/8*	3*/6*	3.2*/10*	2.7*/4.5*	2.5*/3.5*	1.8*/2.5*
5,400	-	1,500	-	-	-	-
13,000/-	8,000/5,100	5,700/2,800	7,500/2,900	11,000/7,600	11,200/7,800	10,000/-
-	180/120	150/70	160/80	225/160	250/180	165/115
55/55	70/80	40/110	35/65	60/60	65/70	30/30
50/-	70/-	35/-	25/25	55/50	45/-	30/-
13/16	13/20	3/9	3.7/6	8/10	6.5/8.5	2.5/4
11/-	-	3.4/-	-	7.5/7	-	2.7/-
260	260	220	220	220	215	220
25, 275 (5)	7, 300 (10)	80, 275 (5)	150, 275 (5)	40, 275 (5)	25, 275 (5)	30, 275 (5)
290 - 300	280 - 300	250 - 275	250 - 275	270 - 290	240 - 265	290 - 310
80 - 90	80 - 90	80 - 90	80 - 90	70 - 90	80 - 90	80 - 90
0.4/290/80	0.4/290/80	0.5/270/80	0.5/270/80	0.3/280/80	0.3/270/80	0.5/290/80
-	0.50 (0.55)	0.80 (0.80)	0.40 (0.90)	0.20 (0.70)	0.25 (0.80)	-

Glass fibre reinforced injection moulding grade with improved flame retardance. Flame retardant based on red phosphorus; giving outstanding electrical properties and very high stiffness and strength.

Impact-modified, carbon fiber reinforced injection-molding grade with reduced surface resistivity. Fire protection based on red phosphorus, for components with increased impact strength and special requirements for electrical properties.

An halogen-free flame-retardant injection molding grade with outstanding free-flow properties, with good electrical properties and low smoke density; resistant to glow wire test GWFI to 960 °C.

Halogen-free flame-proofed injection molding grade with outstanding free-flow properties and good electrical properties; resistant to glow wire test to 960 °C.

Halogen-free flame-proofed injection-molding grade.

Without halogenes flame retarded glass fiber reinforced injection moulding grade; light colorable; outstanding mechanical and electrical properties. In particular optimized for the glow wire requirements of IEC 60335.

Halogen-free injection molding grade with very high rigidity, low smoke density and outstanding electrical properties.

Ultramid® – Injection-molding grades with flame retardants

Reinforced Ultramid® T grades and Ultramid® ONE J grade

Values at 23°C ¹⁾	Unit	Test specification	Condition
Features			
Polymer abbreviation	–	–	–
Density	kg/m ³	ISO 1183	–
Water absorption, saturation in water at 23 °C	%	similar ISO 62	–
Moisture absorption, equilibrium in standard cond. atmo. 23 °C/50 % r.h.	%	similar ISO 62	–
Flammability			
Flammability acc. to UL 94 (thickness)	class (mm)	UL-94, IEC 60695	–
UL (f1) proven for outdoor use: color code, min. thickness	color, mm	UL 746C	–
UL 746 C Fire/ignition performance (UL94+HAI+HWI), min. thickness	mm	UL 746C	–
GWFI (thickness)	°C (mm)	IEC 60695-2-12	–
GWIT (thickness)	°C (mm)	IEC 60695-2-13	–
Oxygen Index	%	ISO 4589-1/-2	–
Testing of materials for automobile interior, Burning rate ≤ 100mm/min, d ≤ 1 mm ⁵⁾	–	ISO 3795, FMVSS 302	–
Railway: Hazard level acc. to requ. sets R22 and R23	class	EN 45545-2	–
Electrical properties			
Relative permittivity at 1 MHz	–	IEC 62631-2-1	dry/cond.
Dissipation factor at 1 MHz	10 ⁻⁴	IEC 62631-2-1	dry/cond.
Volume resistivity	Ω · m	IEC 62631-3-1	dry/cond.
Surface resistivity	Ω	IEC 62631-3-2	dry/cond.
CTI, solution A	–	IEC 60112	–
Thermal properties			
Deflection temperature HDT A (1.80 MPa)	°C	ISO 75-1/-2	–
Deflection temperature HDT B (0.45 MPa)	°C	ISO 75-1/-2	–
Max. service temperature, up to a few hours ²⁾	°C	–	–
Temperature index for 50 % loss of tensile strength after 20,000 h (5,000 h)	°C	IEC 60216	–
RTI "dielectric strength" at 1.5 mm thickness	°C	UL 746B	–
Thermal conductivity, 23 °C	W / (m · K)	DIN 52612-1	–
Specific heat capacity, 23 °C	J/(kg · K)	–	–
Coeff. of linear therm. expansion 23 °C - 55 °C (parallel) (perpendicular)	10 ⁻⁶ /K	ISO 11359-1/-2	–
Mechanical properties			
Tensile modulus of elasticity	MPa	ISO 527-1/-2	dry/cond.
Yield stress (v=50 mm/min), (Stress at break (v=5 mm/min)*)	MPa	ISO 527-1/-2	dry/cond.
Yield strain (v=50 mm/min), (Strain at break (v=5 mm/min)*)	%	ISO 527-1/-2	dry/cond.
Tensile creep modulus, 1,000 h	MPa	ISO 899-1	cond.
Flexural modulus	MPa	ISO 178	dry/cond.
Flexural stress at max. force	MPa	ISO 178	dry/cond.
Charpy unnotched impact strength, 23 °C ³⁾	kJ/m ²	ISO 179/1eU	dry/cond.
Charpy unnotched impact strength, -30 °C ³⁾	kJ/m ²	ISO 179/1eU	dry/cond.
Charpy notched impact strength, 23 °C	kJ/m ²	ISO 179/1eA	dry/cond.
Charpy notched impact strength, -30 °C	kJ/m ²	ISO 179/1eA	dry/cond.
Processing			
Melting temperature, DSC	°C	ISO 11357-1/-3	–
Melt volume-flow rate MVR, test temperature (load)	cm ³ /10 min, °C (kg)	ISO 1133	–
Melt temperature injection moulding	°C	–	–
Mould temperature injection moulding	°C	–	–
Molding shrinkage, test box, d = 1.5 mm, T _M (T _w) ⁴⁾	%, °C (°C)	–	–
Molding shrinkage parallel (perpendicular)	%	ISO 294-4	–

Footnotes

- ¹⁾ For undyed product, unless otherwise indicated in the product designation.
²⁾ Empirical values for parts repeatedly exposed to this temperature for several hours at a time over a period of years, provided that shaping and processing were in accord with the material.
³⁾ N = not broken
⁴⁾ Test box with central gating, base dimensions (107 · 47 · 1.5) mm.
⁵⁾ + = Passed

T KR 4365 G5	T KR 4340 G6	T KR 4341 G6	ONE J 60X1 V30
PA6T/6-GF25 FR	PA6T/6-GF30 FR (40)	PA6T/6-GF30 FR (40)	PA66/6T-GF30 FR(40)
1,380	1,490	1,490	1,410
5 - 6	4.7 - 5.3	4.7 - 5.3	
1.10 - 1.50	2.00 - 2.40	2.00 - 2.40	1.30
V-2 (0.37) V-0 (0.75) 5VA (1.5)	V-0 (0.4) 5VA (1)	V-0 (0.4)	V-0 (0.8) 5VA (0.8)
0.75	0.4	0.4	–
960 (0.75)	960 (0.4)	960 (0.6)	960 (0.8)
775 (0.75)	775 (0.4)	775 (0.6)	800 (0.8)
26	50	–	45
+	+	+	+
4/-	4/4.1	3.9/4.1	–
200/-	150/250	150/250	–
10 ¹³ /10 ¹²	10 ¹⁵ /10 ¹⁵	10 ¹³ /10 ¹³	10 ¹³ /–
–/10 ¹⁴	–/10 ¹⁵	–/10 ¹⁴	–
600	600	600	600
220	240	240	257
–	–	–	275
270	–	–	–
125 (150)	146 (172)	–	–
140	160	85	150
0.31	0.24	0.24	–
1,400	1,200	1,200	–
24 (67)	22 (64)	22.5 (65)	–
8,300/8,000	11,500/11,500	11,500/–	11,000/9,100
150*/140*	155*/135*	155*/–	145*/110*
3*/–	2.5*/2.2*	2.5*/–	2.5*/3.3*
6,400	–	–	–
–	11,000/11,000	11,400/–	9,000/8,000
–	245/215	250/–	230/185
70/55	65/50	65/–	65/62
–	60/–	–	50/–
8/7	6.5/6.5	6.5/–	10/10
–	6.5/–	–	9/–
295	290	290	280
–	25, 325 (5)	20, 325 (5)	–
310 - 330	310 - 330	310 - 330	–
80 - 120	80 - 120	80 - 120	90 - 110
0.4/320/100	0.3/320/100	/320/100	–
0.55 (1.00)	0.30 (0.80)	0.40 (1.00)	0.45 (0.90)
A glass fibre reinforced, flame retardant, partially aromatic polyamide for injection molding. Good mechanical properties, low water absorption, high melting point (295 °C). High tracking resistance, low tendency to form deposits on electrical contacts, very resistant to electrolytic corrosion, resistant to soldering temperatures, can be electroplated.	Partially aromatic polyamid, halogen-free flame-retardant, light colorable, outstanding flame retardance, resistant to soldering temperatures.	Partially aromatic polyamide, halogen-free flame retardant, light colorable, outstanding flame retardance, soldering bath resistant.	Partially aromatic polyamide, halogen-free flame-retardant, with good mechanical and dielectric properties in presence of humidity and at elevated temperatures. It is easily colorable and allows easy processing with low tool corrosion.

Ultramid® – Injection-molding grades with flame retardants

Reinforced Ultramid® Advanced grades

Values at 23°C ¹⁾	Unit	Test specification	Condition
Features			
Polymer abbreviation	–	–	–
Density	kg/m ³	ISO 1183	–
Water absorption, saturation in water at 23 °C	%	similar ISO 62	–
Moisture absorption, equilibrium in standard cond. atmo. 23 °C/50 % r.h.	%	similar ISO 62	–
Flammability			
Flammability acc. to UL 94 (thickness)	class (mm)	UL-94, IEC 60695	–
UL (f1) proven for outdoor use: color code, min. thickness	color, mm	UL 746C	–
UL 746 C Fire/ignition performance (UL94+HAI+HWI), min. thickness	mm	UL 746C	–
GWFI (thickness)	°C (mm)	IEC 60695-2-12	–
GWIT (thickness)	°C (mm)	IEC 60695-2-13	–
Oxygen Index	%	ISO 4589-1/-2	–
Testing of materials for automobile interior, Burning rate ≤ 100mm/min, d ≤ 1 mm ⁵⁾	–	ISO 3795, FMVSS 302	–
Railway: Hazard level acc. to requ. sets R22 and R23	class	EN 45545-2	–
Electrical properties			
Relative permittivity at 1 MHz	–	IEC 62631-2-1	dry/cond.
Dissipation factor at 1 MHz	10 ⁻⁴	IEC 62631-2-1	dry/cond.
Volume resistivity	Ω · m	IEC 62631-3-1	dry/cond.
Surface resistivity	Ω	IEC 62631-3-2	dry/cond.
CTI, solution A	–	IEC 60112	–
Thermal properties			
Deflection temperature HDT A (1.80 MPa)	°C	ISO 75-1/-2	–
Deflection temperature HDT B (0.45 MPa)	°C	ISO 75-1/-2	–
Max. service temperature, up to a few hours ²⁾	°C	–	–
Temperature index for 50 % loss of tensile strength after 20,000 h (5,000 h)	°C	IEC 60216	–
RTI "dielectric strength" at 1.5 mm thickness	°C	UL 746B	–
Thermal conductivity, 23 °C	W / (m · K)	DIN 52612-1	–
Specific heat capacity, 23 °C	J/(kg · K)	–	–
Coeff. of linear therm. expansion 23 °C - 55 °C (parallel) (perpendicular)	10 ⁻⁶ /K	ISO 11359-1/-2	–
Mechanical properties			
Tensile modulus of elasticity	MPa	ISO 527-1/-2	dry/cond.
Yield stress (v=50 mm/min), (Stress at break (v=5 mm/min)*)	MPa	ISO 527-1/-2	dry/cond.
Yield strain (v=50 mm/min), (Strain at break (v=5 mm/min)*)	%	ISO 527-1/-2	dry/cond.
Tensile creep modulus, 1,000 h	MPa	ISO 899-1	cond.
Flexural modulus	MPa	ISO 178	dry/cond.
Flexural stress at max. force	MPa	ISO 178	dry/cond.
Charpy unnotched impact strength, 23 °C ³⁾	kJ/m ²	ISO 179/1eU	dry/cond.
Charpy unnotched impact strength, -30 °C ³⁾	kJ/m ²	ISO 179/1eU	dry/cond.
Charpy notched impact strength, 23 °C	kJ/m ²	ISO 179/1eA	dry/cond.
Charpy notched impact strength, -30 °C	kJ/m ²	ISO 179/1eA	dry/cond.
Processing			
Melting temperature, DSC	°C	ISO 11357-1/-3	–
Melt volume-flow rate MVR, test temperature (load)	cm ³ /10 min, °C (kg)	ISO 1133	–
Melt temperature injection moulding	°C	–	–
Mould temperature injection moulding	°C	–	–
Molding shrinkage, test box, d = 1.5 mm, T _M (T _w) ⁴⁾	%, °C (°C)	–	–
Molding shrinkage parallel (perpendicular)	%	ISO 294-4	–

Footnotes

- ¹⁾ For undyed product, unless otherwise indicated in the product designation.
²⁾ Empirical values for parts repeatedly exposed to this temperature for several hours at a time over a period of years, provided that shaping and processing were in accord with the material.
³⁾ N = not broken
⁴⁾ Test box with central gating, base dimensions (107 · 47 · 1.5) mm.
⁵⁾ + = Passed

Advanced T2340G6	Advanced N3U41G6	Advanced N3U42G6
PA6T/66 GF30 FR (40)	PA9T-GF30 FR (40)	PA9T-GF30 FR (40)
1,440	1,440	1,440
4.4 - 4.6	2	
1.4 - 1.5	1	
V-0 (0.4)	V-0 (0.25) 5VA (1.6)	V-0 (0.4) 5VA (1.5)
	BK, 0.75	
0.4	0.25	0.4
960 (1.5)	960 (1)	960 (0.8)
-	775 (1)	-
-	38	-
+	+	+
3.8/3.9	4.1/3.5	-
110/210	110/160	-
10 ¹⁵ /10 ¹⁵	10 ¹⁵ / $> 10^{15}$	-
-/10 ¹⁵	-/10 ¹⁵	-
600	600	600
275	260	265
-	-	-
-	-	-
-	-	-
150	150	85
-	-	-
-	-	-
21 (61)	19 (53)	-
10,500/10,500	10,500/10,500	10,500/10,500
150*/130*	140*/130*	140*/130*
2.5*/2.7*	2.2*/2.2*	2.2*/2.2*
-	-	-
10,500/10,500	10,500/10,500	10,500/10,500
235/205	220/210	220/210
65/60	60/50	60/50
55/55	60/-	60/-
7/7	7/7	7/7
-	-	-
310	300	300
50, 325 (5)	30, 325 (5)	30, 325 (5)
310 - 330	310 - 340	310 - 340
140 - 160	100 - 160	100 - 160
-	0.45/ 330/140	0.45/330/140
0.40 (1.15)	0.35 (0.95)	0.30 (1.00)

Polyphthalamide, light colorable, with a high melting point, halogen-free flame-retardant, low water absorption, good mechanical and dielectrical properties at elevated temperatures, soldering bath resistant.

Polyphthalamide, light colorable, with a high melting point, halogen-free flame-retardant, very low water absorption, good mechanical and dielectrical properties at elevated temperatures as well as excellent chemical resistance, soldering bath resistant.

Polyphthalamide, light colorable, with a high melting point, halogen-free flame-retardant, very low water absorption, good mechanical and dielectrical properties at elevated temperatures as well as excellent chemical resistance, soldering bath resistant.

Nomenclature

Structure

The name of Ultramid® commercial products generally follows the scheme below:



Subnames

Subnames are optionally used in order to particularly emphasize a product feature that is characteristic of part of a range.

Examples of subnames:

Endure	Particularly good long-term stabilization against hot air
Structure	Particularly good notched impact strength at low temperatures, and with out any disadvantages for the stiffness and strength
Vision	significantly increased translucence in the visible range
Advanced	polyphthalamide
Deep Gloss	high-gloss with increased abrasion resistance and UV stability

Technical ID

The technical ID is made up of a series of letters and numbers which give hints about the polymer type, the melt viscosity, the stabilization, modification or special additives and the content of reinforcing agents, fillers or modifiers. The following classification scheme is found with most products:

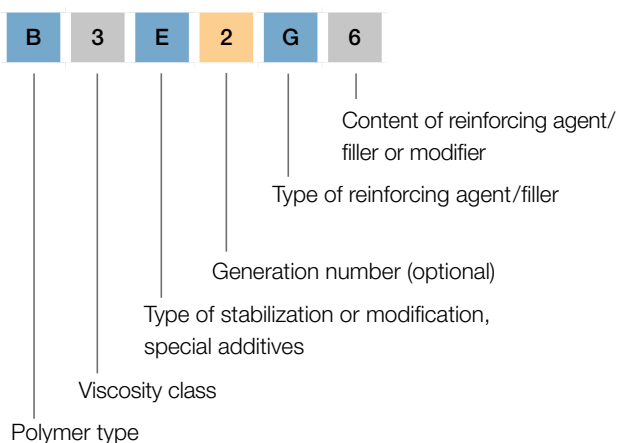

Ultramid® T generally has the following classification scheme:

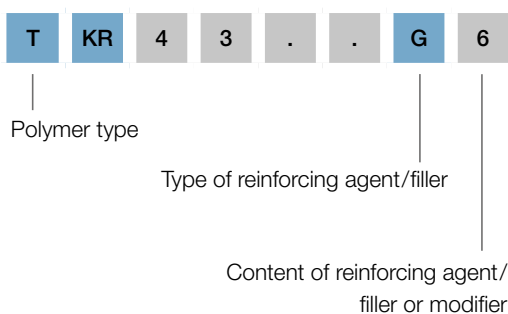

Letters for identifying polymer types

A	Polyamide 66
B	Polyamide 6
C	Copolyamide 66/6
D	Special polymer
S	Polyamide 610
T	Polyamide 6T/6

Numbers for identifying viscosity classes

- 3 Free-flowing, low melt viscosity, mainly for injection-molding
- 35 Low to medium viscosity
- 4 Medium viscosity

Letters for identifying stabilization

- E, K Stabilized, light natural color, enhanced resistance to heat aging, weather and hot water, electrical properties remain unaffected
- H Stabilized, enhanced resistance to heat aging, hot water and weather, only for engineering parts, electrical properties remain unaffected, depending on the grade light-beige to brown natural color
- W Stabilized, high resistance to heat aging, can only be supplied uncolored and in black, less suitable if high demands are made on the electrical properties of the parts

Letters for identifying special additives

- F Functional additive
- L Impact-modified and stabilized, impact resistant when dry, easy flowing, for rapid processing
- S For rapid processing, very fine crystalline structure, for injection-molding
- U With flame-retardant finish without red phosphorus
- X With red phosphorus as the flame-retardant finish
- Z Impact-modified and stabilized with very high low-temperature impact strength (unreinforced grades) or enhanced impact strength (reinforced grades)

Letters for identifying reinforcing agents/fillers

- C Carbon fibers
- G Glass fibers
- K Glass beads
- M Minerals
- GM Glass fibers in combination with minerals
- GK Glass fibers in combination with glass beads

Key numbers for describing the content of reinforcing agents/fillers or modifiers

- 2 approx. 10% by mass
- 3 approx. 15% by mass
- 4 approx. 20% by mass
- 5 approx. 25% by mass
- 6 approx. 30% by mass
- 7 approx. 35% by mass
- 8 approx. 40% by mass
- 10 approx. 50% by mass

In the case of combinations of glass fibers with minerals or glass beads, the respective contents are indicated by two numbers, e. g.

- GM53 approx. 25% by mass of glass fibers and approx. 15% by mass of minerals
- GK24 approx. 10% by mass of glass fibers and approx. 20% by mass of glass beads

M602 represents approx. 30% by mass of a special silicate (increased stiffness).

Suffixes

Suffixes are optionally used in order to indicate specific processing or application-related properties. They are frequently acronyms whose letters are derived from the English term.

Examples of suffixes:

Balance	Based at least partly on renewable raw materials
BM	Blow moulding grade
CR	Crash Resistant
EQ	Electronic Quality
FC	Food Contact; meets specific regulatory requirements for applications in contact with food
GIT	Gas Injection Technology
GP	General Purpose
GPX	New generation „General Purpose“
High Speed	High flowability of the melt
HP	High Productivity
HR	Hydrolysis Resistant, increased hydrolysis resistance
HRX	New generation of HR products
Cond.X	Long Fiber Reinforced
LS	Laser Sensitive, can be marked with Nd:YAG laser
LT	Laser Transparent, can be penetrated well with Nd:YAG lasers and lasers of a similar wavelength
SF	Structural Foaming
SI	Surface Improved, for parts with improved surface quality
ST	Super Tough
WIT	Water Injection Technology

Color

The color is generally made up of a color name and a color number.

Examples of color names:

Uncolored
 Black 00464
 Black 00564
 Black 20560

For your notes

For your notes

Note

The data contained in this publication are based on our current knowledge and experience. In view of the many factors that may affect processing and application of our product, these data do not relieve processors from carrying out own investigations and tests; neither do these data imply any guarantee of certain properties, nor the suitability of the product for a specific purpose. Any descriptions, drawings, photographs, data, proportions, weights etc. given herein may change without prior information and do not constitute the agreed contractual quality of the product. It is the responsibility of the recipient of our products to ensure that any proprietary rights and existing laws and legislation are observed. (September 2022)

Further information on Ultramid® can be found on the internet:

www.ultramid.basf.com

Please visit our websites:

www.plastics.basf.com

www.plastics.basf.de

Request of brochures:

plas.com@basf.com

If you have technical questions on the products, please contact the Ultra-Infopoint:

