

Ultramid® (PA)

Product Brochure

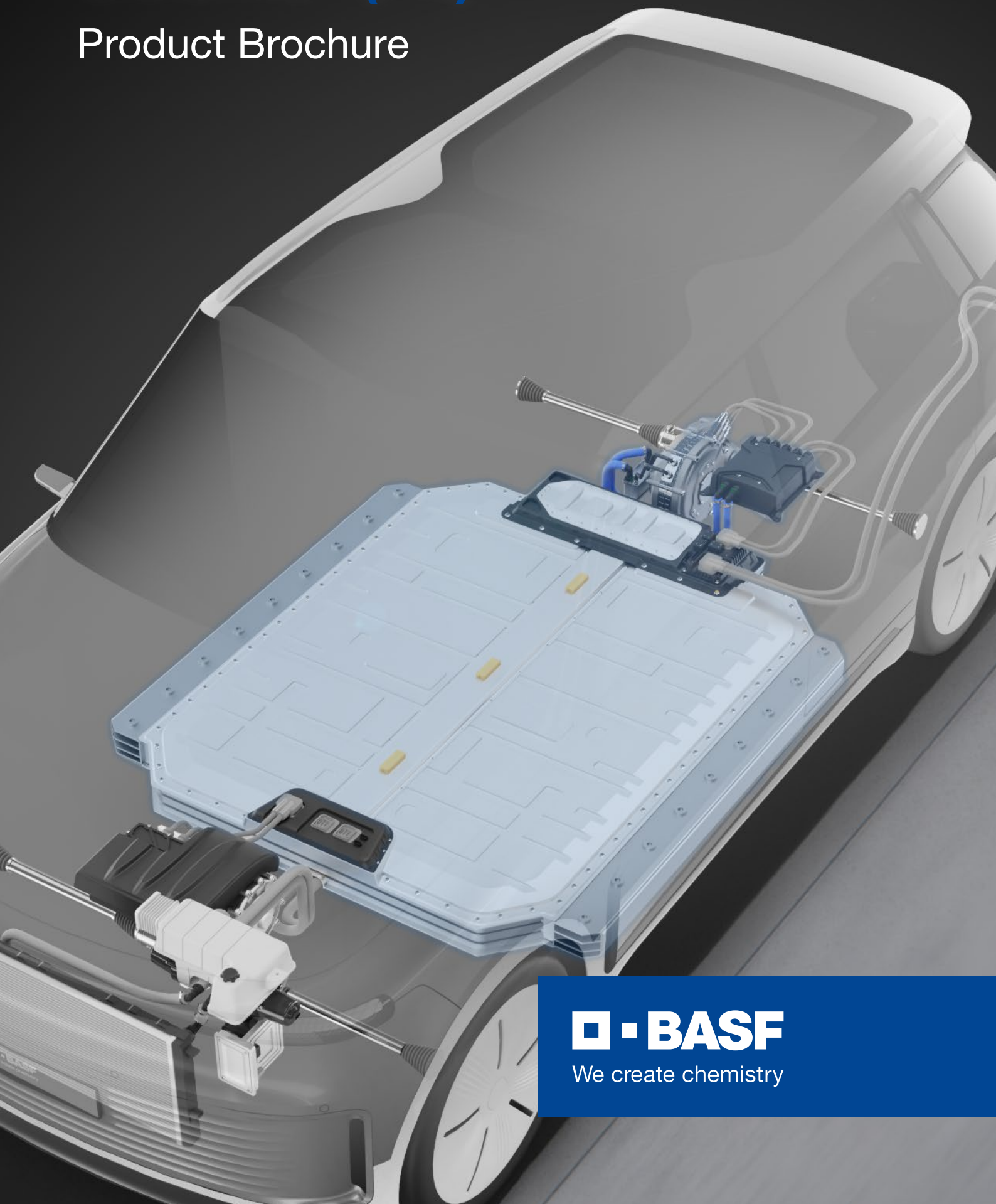

 **BASF**

We create chemistry

Ultramid® (PA)

BASF's Ultramid® grades are molding compounds on the basis of PA6, PA66 and various co-polyamides such as PA66/6. The range also includes PA610 and semi-aromatic polyamides such as PA6T/6. In addition, the polyamide range is supplemented by a polyamide-based particle foam: Ultramid® Expand. The molding compounds are available unreinforced, reinforced with glass fibers or minerals and also reinforced with for special applications. Ultramid® is noted for its high mechanical strength, stiffness and thermal stability. In addition, Ultramid® offers good toughness at low temperatures, favorable sliding friction behavior and can be processed without any problems. Thanks to its excellent properties, this material has become indispensable in almost all sectors of engineering for a wide range of different components and machine elements, as a high-grade electrical insulation material and for many special applications.

Ultramid® (PA)

| | | |
|--|--|-------|
| ULTRAMID® IN AUTOMOTIVE APPLICATIONS | | 4-5 |
| ULTRAMID® IN THE ELECTRICAL AND ELECTRONICS SECTOR | | 6-7 |
| ULTRAMID® FOR HOUSEHOLD AND CONSUMER GOODS | | 8-9 |
| ULTRAMID® PRODUCT RANGE | | 10-25 |
| | Product range | 10 |
| | Semi-aromatic polyamides (PPA) | 18 |
| | Ultramid® S Balance | 22 |
| | Ultramid® Expand | 24 |
| | Ultramid® HPP | 25 |
| THE PROPERTIES OF ULTRAMID® | | 26-46 |
| | Mechanical properties | 26 |
| | Thermal properties | 32 |
| | Water absorption and dimensional stability | 34 |
| | Electrical properties | 36 |
| | Halogen content | 38 |
| | Fire behavior | 38 |
| | Resistance to chemicals | 40 |
| | Behavior on exposure to weather | 46 |
| THE PROCESSING OF ULTRAMID® | | 47-65 |
| | Processing characteristics | 47 |
| | General notes on processing | 49 |
| | Machine and mold technique for injection molding | 50 |
| | Injection molding | 53 |
| | Special processes | 59 |
| | Joining methods | 62 |
| | Machining | 62 |
| | Marking and coating | 62 |
| | Conditioning | 64 |
| | Annealing | 65 |
| GENERAL INFORMATION | | 66-74 |
| | Safety notes | 66 |
| | Sustainability | 67 |
| | Delivery and storage | 69 |
| | Integrated management system | 70 |
| | Services | 70 |
| | Nomenclature | 72 |
| | Subject index | 74 |

Ultramid® in automotive applications

Automotive engineering demands very high quality and safety standards; this is also reflected in the continually increasing demands on the materials used. Ultramid® products possess very good thermal and chemical stability, static and dynamic strength, impact resistance and good long-term performance. These technical properties make them particularly suitable for use in a wide range of automobile components.

The development of Ultramid® products keeps pace with new drive concepts, advances in electrification and trends such as autonomous driving, making it possible to create new components.

Ultramid® products also help to satisfy other requirements for lightweight construction and recyclability.

The comprehensive Ultramid® product range allows customers to select the most appropriate products, enabling them to manufacture components and assemblies economically and competitively.

Typical applications of Ultramid® in motor vehicle construction are:

Combustion engine and transmission:

intake manifolds and charge air distributors, caps and pipes, cylinder head covers, engine covers, oil sumps, oil filter housings, oil sensors, oil modules, chain guide rails, drive belt covers, transmission controls, sensors, roller bearing cages, gear wheels, mounting clips

Electrified powertrain:

battery module housing, end plates, cell holders, busbar holders, cell contacting systems, high-voltage housings, battery ECU housings, electric motor components, high-voltage connectors, charging nozzles, components of fuel cells, hydrogen tank inliners

Cooling system:

radiator caps, thermostat housings, cooling water pipes, cooling water distributors, fan wheels, fan shrouds, quick couplings

Fuel system:

fuel filter housings, fuel lines, carbon canisters, quick connectors

Chassis and engine mounting:

engine mounts, torque arms, coupling rods, transmission cross beams, strut bearings, spring washers

Interior:

pedals and pedal brackets, levers and control elements, door handles, seat structures

Exterior:

structural components, exterior door handles, mirror base plates, wheel trims, front ends, impact absorbers, door and tailgate locking systems

Electrical systems:

plugs, sensors, control unit housing, fuse boxes, switches, relays, generator/electric motor components, actuators, contact and brush holders, bulb sockets, cable ties, clips and conduits, fuel cell components

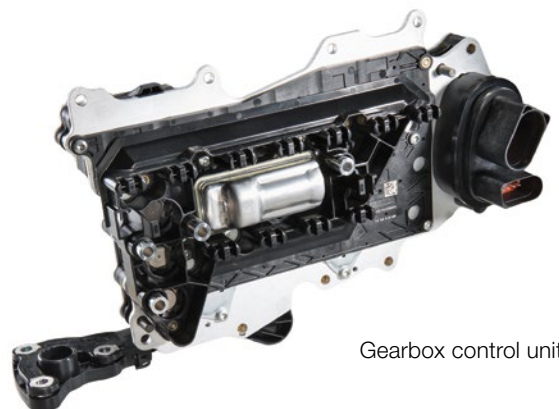

Gearbox control unit



Air and oil suction module



Heat shield



Oil pan



Air intake manifold

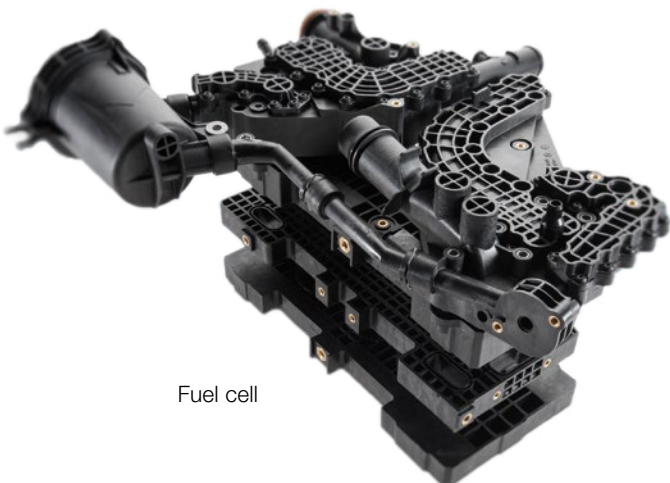

Fuel cell

Ultramid® in the electrical and electronics sector

The good electrical insulation properties, attractive sliding friction behavior, outstanding mechanical strength and a wide range of flame-retardant grades make Ultramid® a material that is used in virtually all areas of industrial power engineering, electronics, domestic appliance technology, and eMobility.

Power technology

High-insulation switch parts and housings, series- and connecting terminals, power distribution systems, cable ducts and fastenings, contactors and power switches, coils, circuit breakers, programmable logic controllers

Electronics

Plug-in connectors, electrical and mechanical components for IT equipment and telecommunications, capacitor cans, chip carriers

Photovoltaics

Connection boxes and plug-in connectors

eMobility

High-voltage connectors, electrical protection devices, charging inlets, loading gun components, structural components for private and public charging stations



Circuit breaker



Photovoltaic connector

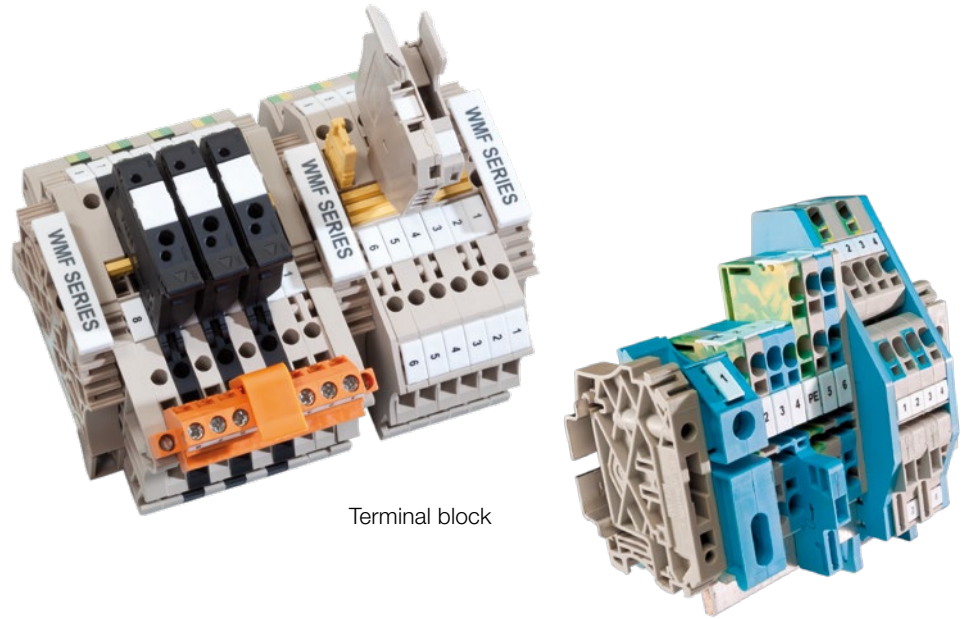

Terminal block

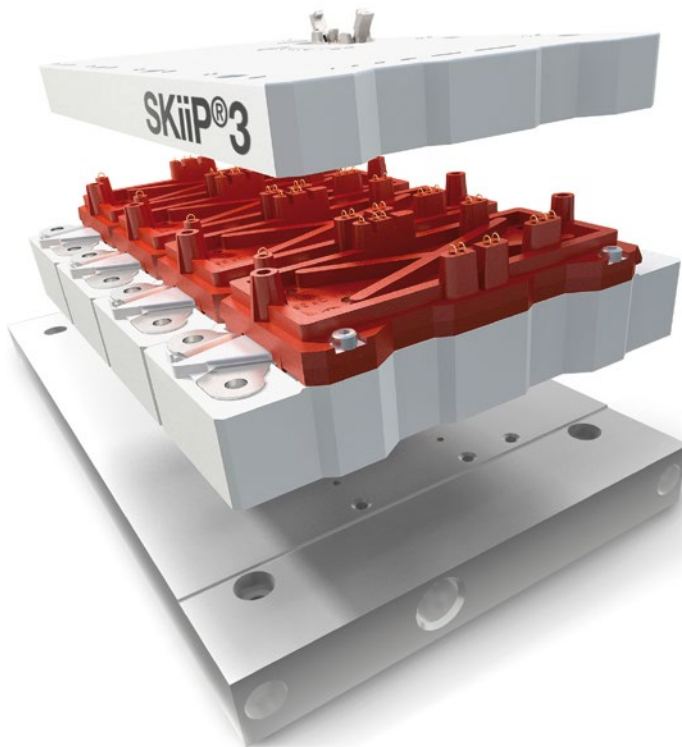

Power electronics

Switch gear



Ultramid® for household and consumer goods

The key to the success of household and consumer goods is excellent performance, long durability and high efficiency. The materials used play a crucial role in the safety of the user and the functionality of the final application. Our solutions enable a long, safe and productive service life.

High mechanical strength combined with good toughness, as well as special solutions for a sustainable product design lead to a wide variety of Ultramid® applications in this market segment.

In many applications, such as power tools, Ultramid® replaces metals, making it even easier and more convenient for the end user to use. In addition, the final articles benefit from the good chemical resistance, an uncomplicated colorability as well as special flame retardant solutions in our Ultramid® portfolio.

An important prerequisite for the household appliance industry is the fulfillment of regulatory requirements in the drinking water and food sector. For this purpose, special Ultramid® products are offered and used.

The varied and in some cases tailor-made properties result in broad application fields such as:

Household goods

Housings and functional components for power tools, large household appliances (white goods) such as washing machines and dishwashers, small appliances, coffee machines, vacuum cleaners, hair dryers

Sanitary services

Handles, brackets and sockets, fixtures, fans, flow water heaters, fittings, water meter housings

Consumer goods and leisure industry

Sports and leisure articles, ski boots and bindings, toys as well as components of electric bicycles

Furniture & Design

Design and office chairs, furniture components such as castors and chair crosses, fittings, frames, dampers and dowels



Design chairs

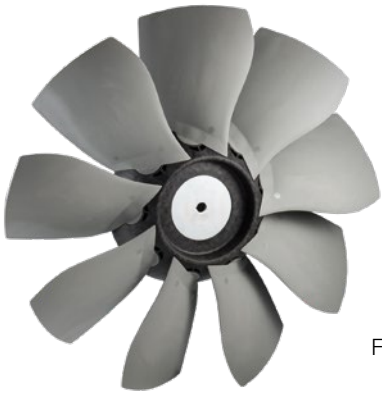

Fan impeller

Frames for office chairs



Dowels



Skateboard



Cooking set

Ski binding



Ultramid® product range

Product range

Ultramid® is the trade name for the polyamides supplied by BASF for extrusion and also particle foams. The product range includes PA66 grades (Ultramid® A), PA6 grades (Ultramid® B), semi-aromatic polyamides (Ultramid® T KR, T6000, T7000, Ultramid® Advanced N, T1000, T2000), specialty polyamides (Ultramid® D), PA610 (Ultramid® S Balance) and special grades based on special copolyamides. Ultramid® A is produced by condensation polymerization of hexamethylene diamine and adipic acid, Ultramid® B by hydrolytic polymerization of caprolactam. These materials are obtained from petrochemical feedstocks such as benzene, cyclohexane and *p*-xylene.

Many products are reinforced with glass fibers or other fillers and contain special additives to improve toughness, flame-retardant properties or resistance to environmental influences in order to allow a wide range of different properties. Ultramid® Advanced and Ultramid® S Balance also have other advantages, such as higher dimensional stability or chemical stability.

The most important characteristics of Ultramid® are:

- High strength and rigidity
- Very good impact strength
- Good elastic properties
- Outstanding resistance to chemicals
- Dimensional stability
- Low tendency to creep
- Exceptional sliding friction properties
- Simple processing

The basis of the Ultramid® grades are polyamides which are supplied in a variety of molecular weights or viscosities, have a range of additives and are reinforced with glass fibers or minerals. More detailed information on the individual products can be found in the Ultramid® product range and the tables 1, 2 and 3.



CEE connector

The Ultramid® range comprises the following groups of products:

Ultramid® A

in its unreinforced state, is an extremely rigid, abrasion-resistant, heat resistant and hard material. It is one of the preferred materials for parts subject to mechanical and thermal stresses in electrical, mechanical and automotive engineering.

Ultramid® B

in its unreinforced state, is a tough, hard material affording parts with good damping characteristics and high shock resistance even in dry state and at low temperatures. It is particularly tough and easy to process. Translucent products are also available under the name Ultramid®.

Ultramid® C

is the name given to copolyamides made from PA6 or PA66 elements that exhibit different melting points or a lower crystallinity according to their composition.

Ultramid® D

are blends of PA6 or PA66 and other polyamides with customized properties, available as unreinforced grades (e.g. Ultramid® D3K) and reinforced grades (e.g. Ultramid® Endure D3G7 SW20560).

Ultramid® S Balance

is particularly resistant to chemicals and is also known for its low moisture absorption. Ultramid® S Balance is preferably used in components that come into contact with media.

Ultramid® T6000

is a high temperature polyamide (PA66/6T) with good mechanical and dielectric properties, even in humid condition and at elevated temperatures. It has good colorability and is similarly easy to process as a standard polyamide, with low tool corrosion. Therefore, it closes the gap between PA66 and the Ultramid® Advanced (PPA) portfolio for E&E applications.

Ultramid® T7000

is a blend of PA and PPA and has a higher, more resistant stiffness and strength than PA66. Especially for metal replacement in structural components exposed to moisture.

Ultramid® T KR

has a semi-aromatic structure and is a highly rigid material with a high melting point, known for its dimensional stability, high chemical resistance and constant mechanical properties covering a wide range of different applications.

Ultramid® Advanced T1000

has a very high, constant stiffness and strength over a temperature range of -40 °C to over 80 °C. It is resistant to high temperatures and against aggressive media.

Ultramid® Advanced T2000

is a polyphthalamide providing good E&E performance with a high melting point, low water absorption, good mechanical properties at high temperatures and good chemical resistance.

Ultramid® Advanced N

is characterized by very low water absorption, excellent chemical resistance and good mechanical properties at high temperatures in conditioned state.

Ultramid® Expand

is a polyamide-based particle foam and is characterized by excellent heat resistance, high rigidity in combination with high toughness. In addition it has good chemical resistance to oils, fuels and lubricants.



Snowboard binding

Glass-fiber reinforced Ultramid®

These materials are distinguished by high mechanical strength, hardness, rigidity, thermostability and resistance to hot lubricants and hot water. Parts made from them show dimensional stability and high creep strength. Glass fiber-reinforced Ultramid® T KR also has extraordinarily high heat distortion temperature (up to 280 °C).

Special glass-fiber reinforced materials can be found under trade name Ultramid® XCD, which are particularly reinforced with flat glass-fibers and therefore particularly low-distortion. They are also characterized by high fatigue strength and further increased mechanical especially notched impact strength. In addition, under the suffix XP (e.g. Ultramid® B3WG10 XP) glass-fiber reinforced Ultramid® is also available, which offers significantly increased strength and stiffness, as well as impact strength compared to standard products.

Tough modified Ultramid®

Tough modified materials are available both unreinforced and with glass fiber or mineral reinforcement. These are particularly ductile materials that have very high impact strengths at room temperature as well as at low temperatures. Ultramid® B3Z5 is a highly impact-modified PA6 (polyamide 6), which has excellent low-temperature impact strength and ductility. It is also resistant to cathodic dip coating, which makes it ideal for structural inserts in automotive engineering.

Ultramid® with recycled content

Materials with a recycled content of 20 % to 50 % are identified by the suffix RC. We use high-quality post-consumer (RC1) and post-industrial waste sources (RC2). Our RC products achieve a quality as good as new and are suitable for demanding applications, with the exception of contact with food.

| Ultramid® | Polyamide | Chemical structure | Melting point [°C] |
|--------------------------|-----------|--|--------------------|
| Ultramid® A | 66 | base hexamethylene diamine, adipic acid | 260 |
| Ultramid® B | 6 | polycaprolactam – NH (CH ₂) ₅ CO | 220 |
| Ultramid® C | 66/6 | base hexamethylene diamine, adipic acid, caprolactam | 242 |
| Ultramid® S Balance | 610 | base hexamethylene diamine, sebacic acid | 222 |
| Ultramid® T | 6T/6 | copolymer of caprolactam hexamethylene diamine and terephthalic acid | 295 |
| Ultramid® Advanced N | 9T | base nonane diamine, terephthalic acid | 300 |
| Ultramid® Advanced T1000 | 6T/6I | base hexamethylene diamine, terephthalic acid, isophthalic acid | 325 |
| Ultramid® Advanced T2000 | 6T/66 | base hexamethylene diamine, terephthalic acid, adipic acid | 310 |
| Ultramid® T6000 | 66/6T | base hexamethylenediamine, terephthalic acid | 285 |
| Ultramid® F | 6/636 | base caprolactam, hexamethylenediamine, C36 dicarboxylic acid | 196 |

Table 1: Ultramid® base polymers

Reinforced and unreinforced grades with flame retardants

The specially modified grades Ultramid® C3U, B3UG4, B3U30G6, B3U42G6, B3U50G6, A3X2G5, A3X2G7, A3X2G10, A3U42G6, A3U44G6, T KR 4365 G5, T KR 4340 G6 and T KR 4341 G6 are particularly suitable for electro-technical components with higher fire protection requirements and high tracking resistance. If very good dielectric properties are also required in warm and humid climates, the semi-aromatic grades Ultramid® T6340G6, Advanced T2340G6 and Advanced N3U41G6 are used. The Ultramid® A3U44G6 DC and Advanced N3U42G6 grades are specially optimized for eMobility applications. For extremely high demands on cold impact strength, such as in photovoltaics, the high impact modified Ultramid® A3XZG5 is used. Due to the reinforcement with carbon fibers, Ultramid® A3XZC3 ESD, which is also highly impact modified, is used in applications where reduced electrical surface resistance is required.

Mineral- and glass bead-filled Ultramid®

Materials filled with minerals and glass beads show increased rigidity, good dimensional stability, low tendency to warp, optically appealing surfaces, partly excellent ability for metallizing and good flow characteristics.



Door handle



High-voltage connector

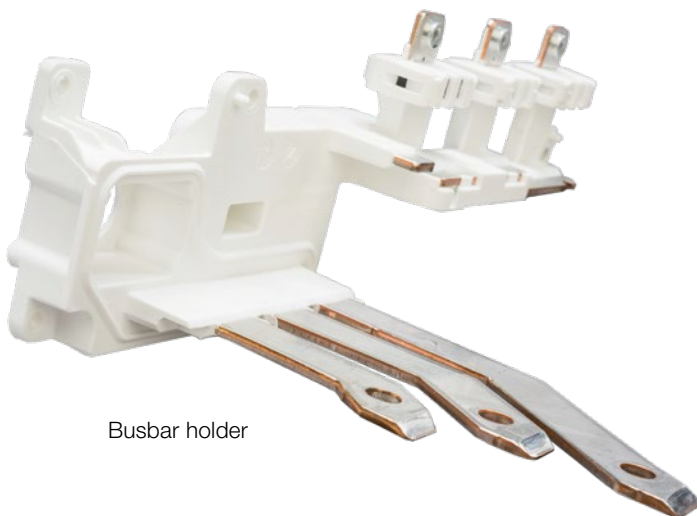

Busbar holder



Quick connector

| Ultramid® A | | F ¹⁾ | W ²⁾ | | |
|---|---|-----------------|--|---|--|
| Injection molding grades (unreinforced) | A3K, A3SK | ✓ | | easy flowing, fast processing | |
| | A3W | | | | |
| | A4K | | | medium viscosity, high impact strength even at dry state | |
| | A4H | | | | |
| | A3L HP | | | highly heat-stabilized, high flowability, high impact strength | |
| | A3Z | | | high impact strength even at dry state and low temperatures | |
| | A3...Z3/Z4 | ✓ | | medium to highest level of toughness, fast processing | |
| | Special products | | | | |
| A3K FC Aqua® | | | with material approvals for drinking water or food contact | | |
| Injection molding grades (reinforced) | A3E...G3/G5/G6/G7/G10 | ✓ | | good dielectric properties | |
| | A3H...G2/G5/G7/G10 | | | high heat-aging resistance even in contact with lubricants combined with good dielectric properties | |
| | A3W...G3/G5/G6/G7/G8/G10 | | | very high heat-aging resistance | |
| | A3Z...G3/G6 | | | high impact strength even at dry state and low temperatures | |
| | A3K6 | | | glass bead reinforcement to achieve high dimensional stability, low warpage, and good surface appearance | |
| | A3WGM53 | | | glass and mineral reinforced grade with medium rigidity and strength as well as low warpage | |
| | Special products | | | | |
| | A3E...G6/G7 FC Aqua® | | | with material approvals for drinking water or food contact | |
| | A3E...G6/G7 EQ | | | meets special purity requirements for sensitive applications in electronic industry | |
| | A3EG6 LT | | | laser transparent black material for laser welding | |
| | A3WG6 LT | | | laser-transparent, black material with very high heat-aging resistance for laser welding | |
| | A3HG6 Balance | | | with improved hydrolysis resistance and special stress cracking resistance | |
| | A3HG6 HR | | | with improved hydrolysis resistance | |
| | A3W...G6/G7 HRX | | | with further improved hydrolysis resistance | |
| | A3H...G6/G7 | | | with further improved hydrolysis resistance | |
| | A3HG6 WIT | | | suited for processing by water injection technology (WIT) | |
| | A3W2...G6/G10 | | | with further improved heat-aging resistance | |
| | A3W G10 HP | | | with good flowability and very high heat ageing resistance | |
| | A3WC4 | | | with carbon fiber reinforcement for high-rigidity applications | |
| | Ultramid® B | | | | |
| | Injection molding grades (unreinforced) | B3K | ✓ | | easy flowing, fast processing, high impact resistance in the conditioned state |
| B3S | | ✓ | | | |
| B3W | | | | medium viscosity, stabilized against heat-aging | |
| B35W | | | | | |
| B3L ZS | | ✓ | | high impact strength even at dry state | |
| B3...Z1/Z2/Z4/Z5 | | | | increased toughness even at dry state and at very low temperatures | |
| B4Z8 R01 | | | | plasticized, highly impact-modified, extrudable | |
| Special products | | | | | |
| B3S HP | | | | optimized demolding for very short cycle times without special heat stabilization | |
| B5Z BM | | | high viscosity/melt stability, high impact strength even when dry, especially at very low temperatures | | |
| Injection molding grades (reinforced) | B3...G4/G6/G7/G8/G9/G10 | ✓ | | fiber-reinforced products | |
| | B3E...G3/G4/G5/G6/G7/G8/G9/G10 | ✓ | | good dielectric properties | |
| | B3E2...G3/G6/G9/G11 | ✓ | | UV-stabilized for improved lightfastness, e.g. for ski bindings or automotive interiors | |
| | B3H...G7 | | | high heat-aging resistance even in contact with lubricants combined with good dielectric properties | |
| | B3W...G3/G5/G6/G7/G8/G9/G10 | | | very high heat-aging resistance | |
| | B3WG6 GPX | | | with further improved heat aging and bursting pressure resistance, e.g. for use in the charge air section | |
| | B3Z...G3/G6/G7/G8/G9/G10 | | | high impact strength even at dry state and low temperatures | |
| | B3GK24 | ✓ | | glass-fiber and glass-beads reinforced, low warpage | |
| | B3...K3/K6 | ✓ | | glass-bead reinforced to achieve high dimensional stability, low warpage and good surface appearance | |

| Ultramid® B | | F ¹⁾ | W ²⁾ | |
|---|--|-----------------|--|--|
| Injection molding grades (reinforced) | B3W...GM24/GM35 | | | glass-fiber and mineral reinforced with medium to high rigidity and strength, low warpage |
| | B3WGM24 HP | | | glass-fiber and mineral reinforced with medium to high rigidity and strength, low warpage and optimized demolding for fast cycle times |
| | B3WM8 | | | mineral reinforced with optimized surface as well as low distortion, e. g. for electroplating processes |
| | B3M6 | | | mineral filled, with medium rigidity and strength, low warpage |
| | B5Z BM | | | high viscosity/melt stability, high impact strength even when dry, especially at very low temperatures |
| | Special products | | | |
| | B3E...G4/G6/G8/G10 SI | | | surface improved for excellent visual appearance |
| | B3EG6...EQ/HPP/HSP | | | meets the special demands on purity for sensitive applications in the electronics industry |
| | B3H...G6/G7 HR | | | with improved hydrolysis resistance |
| | B3W...G6/G7/G8/G12 High Speed | | | excellent flow properties and fast cycle times |
| B3WG6 GIT | | | suited for processing for gas injection technology (GIT) | |
| B3PG6 | | | highest heat aging resistance, metal and halide free | |
| Ultramid® D | | | | |
| Injection molding grades (reinforced) | Endure D3G7 | | | very high level of heat-aging resistance |
| Blow molding grades (reinforced) | Endure D5G3 BM | | | highest heat-aging resistance, e. g. for parts in the charge air duct |
| Ultramid® Expand | | | | |
| Particle foam (unreinforced) | D4H2925 | | | ideal for large components with low density |
| | D4H3510 | | | ideal for large, delicate components with low density |
| Ultramid® F | | | | |
| Injection molding grades (reinforced) | F3EG10 Aqua | | | high-stiffness injection-molding grade for hot and cold water applications |
| Ultramid® S | | | | |
| Injection molding grades (unreinforced) | S3W Balance | | | high flowability, fast processing |
| | S3Z4 Balance | | | impact-modified, especially suitable for applications within the sports and leisure industry |
| | S3Z5 Balance | | | impact-modified, especially suitable for applications within the sports and leisure industry, extrusion applications |
| Injection molding grades (reinforced) | S3EG6 Balance Aqua® | | | suitable for hot and cold water applications |
| | S3WG6 Balance | | | excellent heat-aging and hydrolysis resistance |
| | S3ZG4 BAL | | | high impact resistant modified for power tools |
| Ultramid® T7000 | | | | |
| Injection molding grades (reinforced) | T7300EG10 | | | high stiffness and strength, low water absorption, for metal replacement |
| Ultramid® T KR | | | | |
| Injection molding grades (unreinforced) | T KR 4350 | | | easy flowing, fast processing |
| Injection molding grades (reinforced) | T KR 4355...G5/G7/G8/G10 | | | fiber-reinforced products |
| | T KR 4357 G6 | | | fiber-reinforced and impact-modified |
| | Special products T KR 4355 G5 LS | | | especially suitable for laser markable parts |
| Ultramid® Advanced T1000 | | | | |
| Injection molding grades (reinforced) | T1000H...G6/G7/G8/G10 | | | high stiffness and strength up to over 80 °C and in conditioned state, resistant against aggressive media |
| Ultramid® Advanced T2000 | | | | |
| Injection molding grades (reinforced) | T2300EG6 | | | excellent flowability, high HDT, good E&E performance |
| | T2300HG6 | | | excellent flowability, high HDT, good E&E performance |
| Ultramid® Advanced N | | | | |
| Injection molding grades (unreinforced) | N4H | | | dimensionally stable and resistant, also against wear and abrasion |
| Injection molding grades (reinforced) | N3HG6 | | | high flowability, for E&E applications, JEDEC class 1 |
| | N4HG7 | | | high level of toughness, especially resistant to chemicals, for applications in the automotive sector |
| | N4WG7 | | | high toughness, excellent resistance against heat and chemicals, for automotive applications |

Table 2: Ultramid® range without flame retardant types

¹⁾ Available in different colors (apart from black and natural)

²⁾ Level of heat stability:



| | Product | UL 94 | RTI _{elec} d=1.5 mm | GWIT ≥ 775 GWFI ≥ 850 d = 1.5 mm | Halogen-free flame retardant | Symbol |
|-------------------------------|---------------------------|-----------|---------------------------------|--|------------------------------|--------------------------|
| Ultramid® unreinforced | A3K R01 | V-2, 0.4 | 125 °C | + | + ¹⁾ | PA66 |
| | A3U32 | V-0, 0.25 | 130 °C | | | PA 66 |
| | C3U | V-0, 0.4 | 120 °C | + | + | PA66/6 FR(30) |
| | B3S R03 | V-2, 0.8 | 130 °C | + | + ¹⁾ | PA6 |
| Ultramid® reinforced | A3UG5 | V-0, 0.75 | 120 °C | | + | PA66 GF25 FR(40) |
| | A3U42G6 | V-0, 0.4 | 150 °C | | + | (PA66-Blend) GF30 FR(40) |
| | A3U44G6 DC | V-0, 0.4 | - | | + | (PA66-Blend) GF30 FR(40) |
| | A3X2G5 | V-0, 0.8 | 120 °C | | + | PA66 GF25 FR(52) |
| | A3XZG5 | V-0, 1.5 | 120 °C | | + | PA66-I GF25 FR(52) |
| | A3X2G7 | V-0, 0.75 | 115 °C | | + | PA66 GF35 FR(52) |
| | A3X2G10 | V-0, 1.5 | 115 °C | | + | PA66 GF50 FR(52) |
| | A3XZC3 ESD | V-0, 1.5 | - | | + | PA66-I CF15 FR(52) |
| | B3UG4 | V-2, 0.71 | 140 °C | | + | PA6 GF20 FR(30) |
| | B3U30G6 | V-2, 0.75 | 140 °C | | + | PA6 GF30 FR(30) |
| | B3U42G6 | V-0, 0.4 | 130 °C | | + | PA6 GF30 FR(40) |
| | B3U50G6 | V-0, 0.8 | 150 °C | + | + | PA6 GF30 FR(53) |
| | B3UGM210 | V-0, 1.5 | 130 °C | | + | PA6 GF10 M50 FR(61) |
| | T KR4365 G5 | V-0, 0.75 | 140 °C | + | + | PA6T/6 GF25 FR(52) |
| | T KR4340 G6 | V-0, 0.4 | 160 °C | + | + | PA6T/6 GF30 FR(40) |
| | T KR4341 G6 | V-0, 0.4 | - | | + | PA6T/6 GF30 FR(40) |
| | Ultramid T6000 reinforced | T6340G6 | V-0, 0.4 | 150 °C | + | + |
| Ultramid® Advanced reinforced | T2340G6 | V-0, 0.4 | 150 °C | | + | PA6T/66 GF30 FR(40) |
| | N3U41G6 | V-0, 0.25 | 150 °C | + | + | PA9T GF30 FR(40) |
| | N3U42G6 | V-0, 0.4 | - | + | + | PA9T GF30 FR(40) |

Table 3: Overview of reinforced and unreinforced grades with flame retardants

¹⁾ Product does not contain flame-retardant additive



Emergency switch

| Electrical household appliances | Terminal blocks | Connectors | Circuit breakers | Low-voltage switch gears | Photovoltaics | Automotive/ eMobility | Railway vehicles | Power electronics |
|---------------------------------|-----------------|------------|------------------|--------------------------|---------------|-----------------------|------------------|-------------------|
| ● | ○ | ● | | | ○ | ○ | | |
| ● | ● | ○ | | ○ | | ○ | ○ | |
| ● | ● | ○ | | ○ | | ○ | ○ | |
| ● | ○ | ○ | | | | ○ | | |
| | | ○ | ○ | ● | | ● | ○ | |
| | | ○ | ○ | ● | | ● | ○ | |
| | | ○ | | ● | ● | ○ | | |
| | | ○ | | ○ | ● | ○ | | |
| | | ○ | | ● | ● | ○ | | |
| | | ○ | | ● | | ○ | | |
| | | ○ | ● | ○ | ○ | | ○ | |
| | | ○ | ● | ○ | | ○ | | |
| ● | | ● | ● | ● | | ● | ○ | |
| | | ○ | ● | ● | | ○ | | ○ |
| ● | | ○ | | ○ | | | | |
| ● | | ○ | ○ | ○ | | | | |
| ○ | | ○ | ○ | ○ | | ● | | ● |
| ● | | ○ | ● | ● | | ● | | |
| | | ● | ○ | ● | | ● | | ● |
| ● | | ● | ○ | ● | | ● | | |
| ○ | | ● | | | | ● | | ● |

● Main field of application ○ Other fields of application



Water meter housing

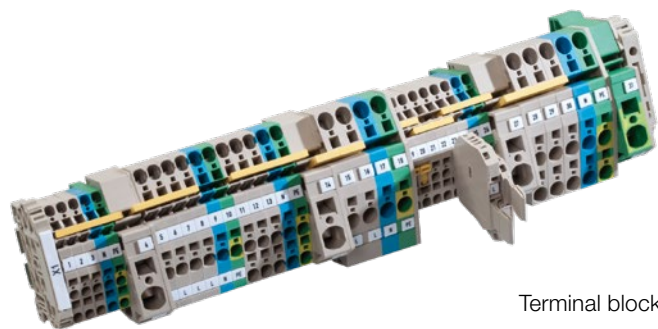

Terminal blocks

Semi-aromatic polyamides (PPA)

BASF offers a portfolio of polyphthalamides (PPA) based on four PPA polymers and comprising more than 50 compounds, which are described in more detail in separate brochures. The PPA portfolio includes Ultramid® Advanced N (PA9T), Ultramid® Advanced T1000 (PA6T/6I), Ultramid® Advanced T2000 (PA6T/66) and Ultramid® T KR (PA6T/6). In addition, BASF offers the Ultramid® T6000 (PA66/6T) and the Ultramid® T7000 grades (PA/PPA blends), which close the performance gap between PPAs and PA66. The PPA portfolio is globally available and is complemented by the BASF simulation tool Ultrasim® and extensive experience in application development.

Ultramid® Advanced N

A high-performance polyphthalamide with constant mechanical properties up to 100°C (glass transition temperature: 125°C) combined with outstanding chemical resistance, low water absorption and good tribological properties. The material permits a wide processing window and short cycle times. Parts made of Ultramid® Advanced N are lighter, smaller and stronger. The material can solve a wide range of application problems: Ultramid® Advanced N is suitable for small connectors and functionally integrated housings in domestic appliances, consumer electronics and mobile devices. It can be used in automotive and structural parts near the engine and the transmission system, which are in contact with hot, aggressive media and different fuels. Ultramid® Advanced N can also be used in applications such as gear wheels and other wear parts.

Ultramid® Advanced T1000

Within the Ultramid® family, Ultramid® Advanced T1000 is the strongest and stiffest product group. It has consistent mechanical properties at temperatures of up to 120°C (dry) and up to 80°C (conditioned). Thanks to its semi-aromatic chemical structure, it shows low water absorption and is highly resistant to aggressive media. Ultramid® Advanced T1000 can be used in the automotive industry, particularly in areas where materials have to remain strong to whatever temperatures or climates they are exposed to; it can also be used in all other industries which require dimensional stability or resistance to chemicals, e.g. thermostat housings and water pumps, in vehicle fuel systems, exhaust gas recirculation, actuators and clutch components, in coffee machines, furniture fittings and in structural applications such as water distributors, heating systems and pumps.

Ultramid® Advanced T2000

A polyphthalamide combining excellent mechanical, insulation and dielectric properties at high temperatures. Due to its semi-aromatic chemical structure, Ultramid® Advanced T2000 is the ideal solution for components that require a high degree of consistent stiffness and strength over a wide temperature range, combined with heat resistance, low moisture uptake and optimal flame retardance. The PPA has the same level of impact resistance as standard PA66 and lower water absorption than aliphatic standard polyamides, which gives it a high degree of dimensional stability. The high melting point (310°C) and high heat resistance (> 280°C, HDT-A) make it a suitable material for lead-free soldering, while preventing component deformation. It can therefore be used to manufacture sensitive connectors, structural components in laptops and circuit breakers.



Thermostat housing

Ultramid® T KR

The partially aromatic polyamide Ultramid® T KR has outstanding properties:

- Dimensional stability even at higher temperatures (melting point: 295 °C)
- Excellent stiffness and strength
- Mechanical properties uncompromised by external condition
- Toughest of all partially aromatic polyamides
- Low shrinkage and warpage
- Slow water absorption
- Good chemical resistance
- Excellent electrical properties

The highly glass fiber-filled grades are particularly suitable as a substitute for metal because of their high mechanical strength.

Mechanical properties

In comparison to conventional polyamides (e.g. PA6 or PA66), Ultramid® T KR is noted for its much slower water absorption. Furthermore, moisture absorption does not result in any significant change to the mechanical properties at room temperature because of the basically higher glass transition temperature of Ultramid® T KR (Fig. 1).

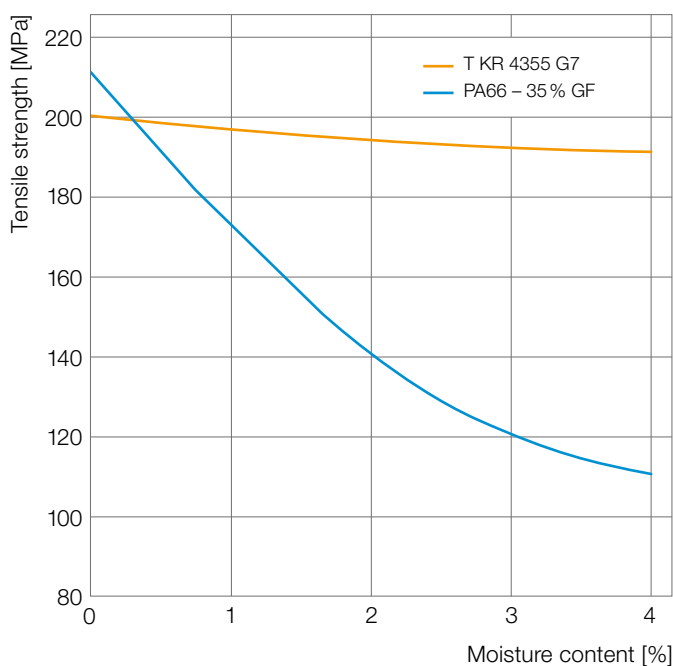

Fig. 1: Tensile strength of Ultramid® T KR compared to PA66 at 23 °C, different moisture contents

Semi-aromatic polyamides are generally not the toughest materials. Because of its molecular structure, Ultramid® T KR has significantly higher impact resistance values than other semi-aromatic polyamides (Fig. 2) and does not lose its impact resistance in cold environments or in the dry state. Due to its excellent toughness in cold environments and in dry state, Ultramid® T KR is ideally suited, e.g. as material for plugs and connectors.

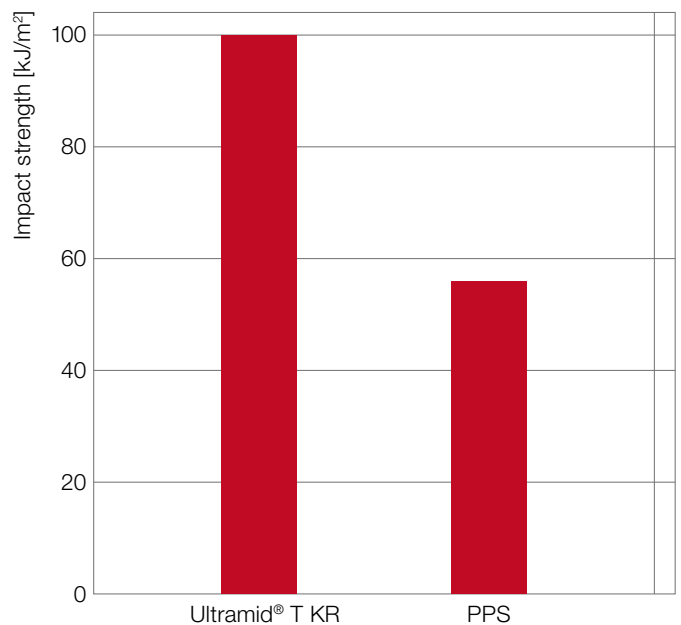

Fig. 2: Impact strength (23 °C) of Ultramid® T KR compared to PPS (glass fiber content: 30-35 %)

Chemical resistance

Like all polyamides, Ultramid® T KR also shows excellent chemical resistance. The material also offers other advantages compared to polar substances such as alcohols and aqueous calcium and zinc chloride solutions. Moreover, the strength and rigidity reduction and the change in volume are much lower with Ultramid® T KR than with a PA6.

Shrinkage and warpage

Products based on Ultramid® T KR show lower shrinkage in the longitudinal and transverse direction in comparison to PA66. Depending on the component geometry, this leads to extremely low warpage. In addition, as a result of the slow water absorption compared with standard polyamides, components made from Ultramid® T KR have significantly higher dimensional stability under different external conditions.

For more information, see the Ultramid® T KR Flyer.

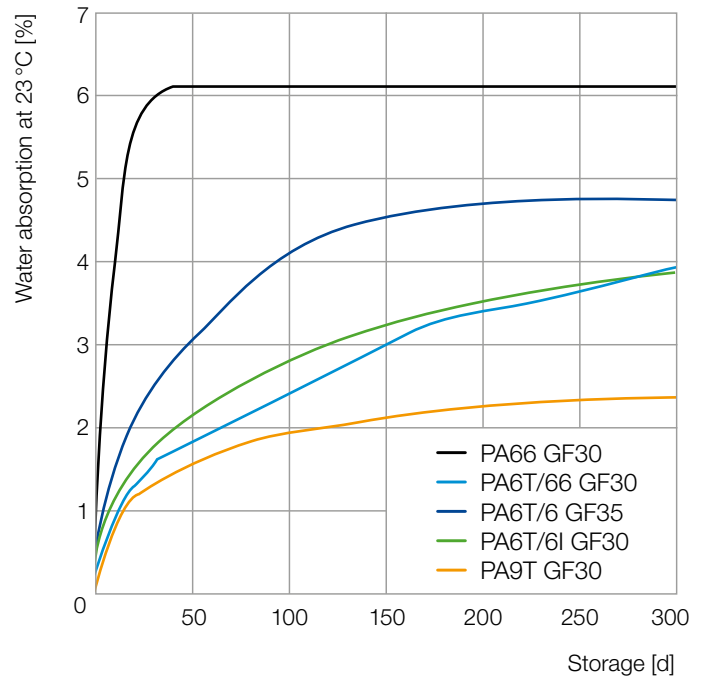

Fig. 3: Water absorption of different PPA types compared to PA66

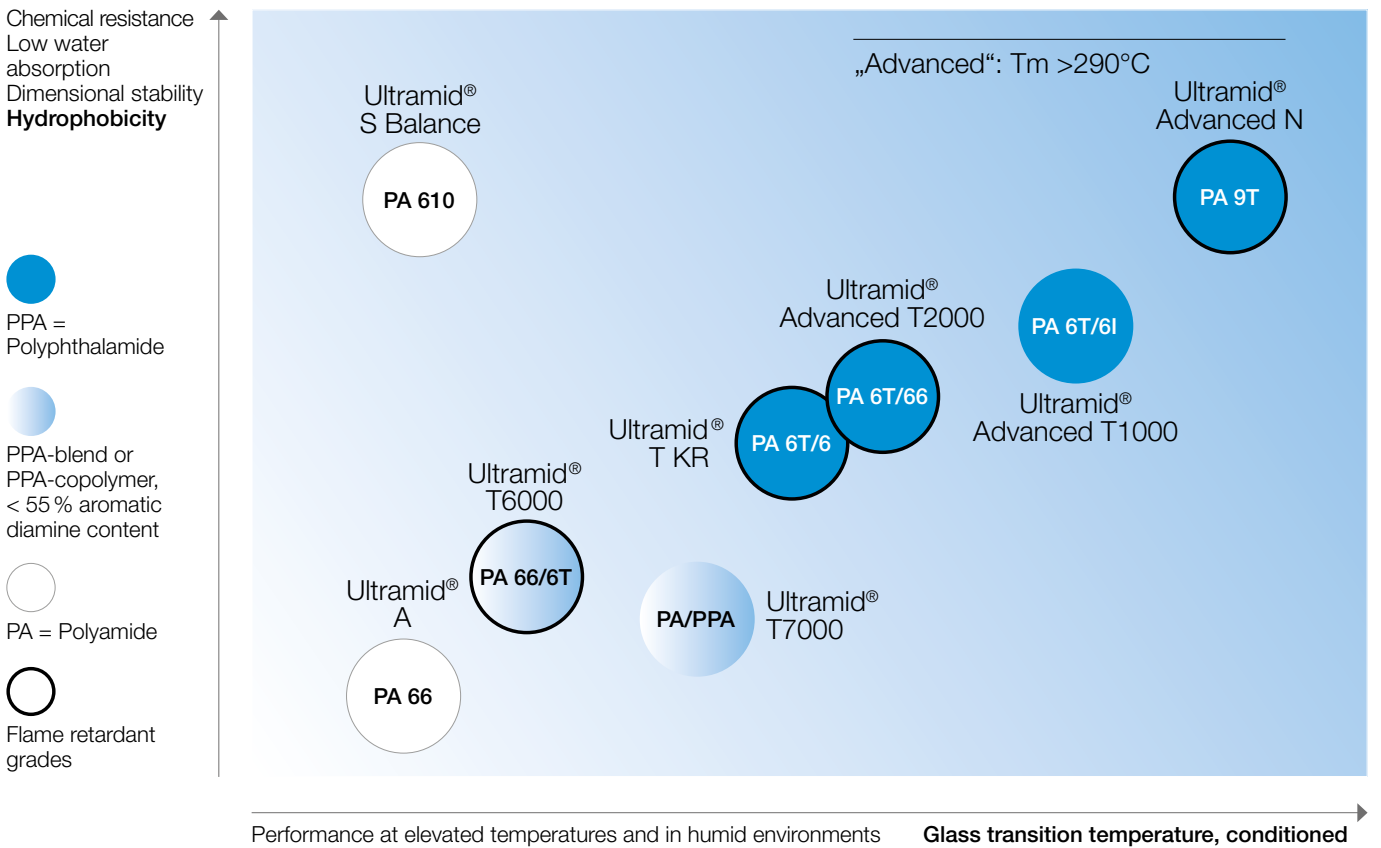

Fig. 4: Technical positioning of Ultramid® PPA grades compared to PA66

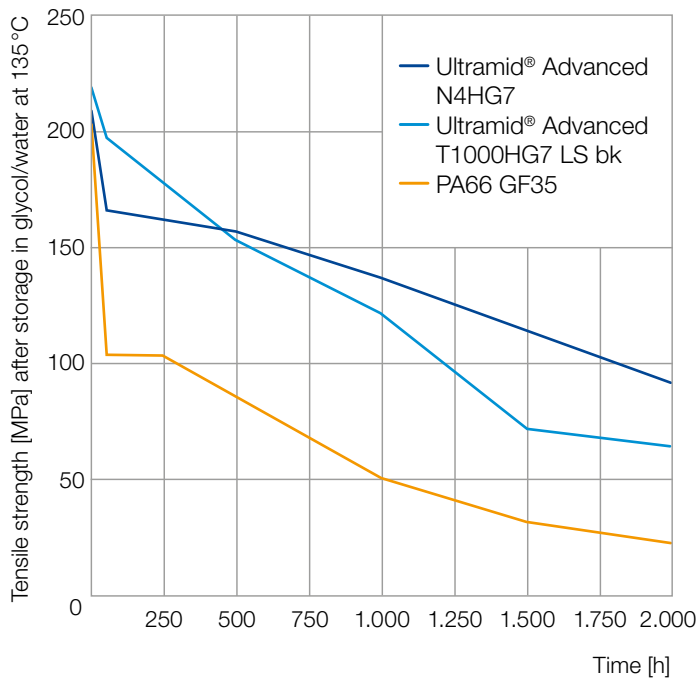

Fig. 5: Tensile strength of different PPA types compared to PA66

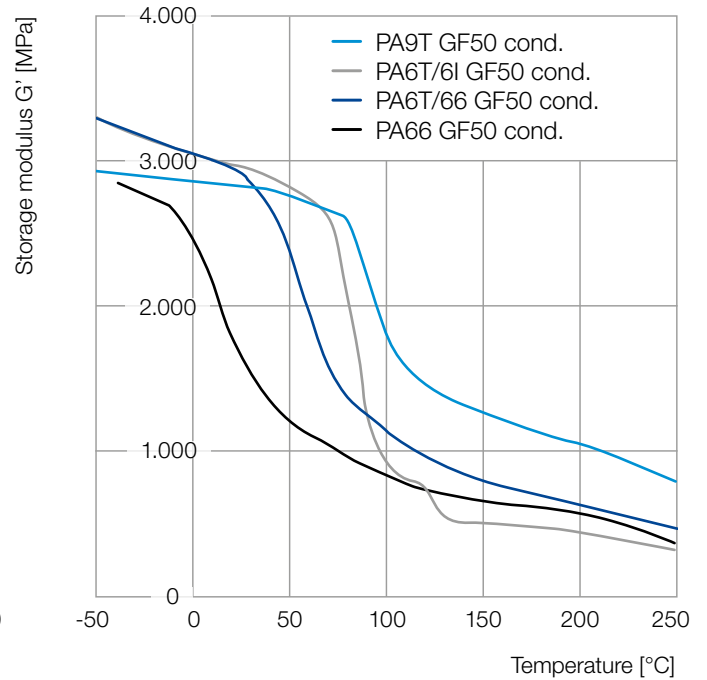

Fig. 6: Storage modulus of different PPAs compared to PA66

| Application/technology | Ultramid® T6000 | Ultramid® T7000 | Ultramid® T KR | Ultramid® Advanced T1000 | Ultramid® Advanced T2000 | Ultramid® Advanced N |
|-----------------------------------|-----------------|-----------------|----------------|--------------------------|--------------------------|----------------------|
| Consumer electronics ¹ | | *** | ** | * | *** | *** |
| E&E Connectors ¹ | | *** | *** | * | *** | *** |
| eMobility ¹ | | ** | ** | * | *** | *** |
| Extrusion | | | | | | *** |
| Fuel cell | * | ** | * | *** | * | *** |
| Gear wheels | | | * | | ** | *** |
| Household appliances | *** | ** | * | *** | * | ** |
| LED | | | | | | *** |
| Powertrain | ** | | ** | *** | ** | *** |
| Pumps | *** | | ** | *** | * | ** |
| Sensors ¹ | | | ** | *** | *** | *** |
| Water meter | *** | | ** | *** | * | ** |

¹ Flame retardant grades available: more information can be found in the separate Ultramid® PPA flame retardant flyer

*** perfect fit / ** good fit / * moderate fit

Table 4: Possible applications for the different PPA types

Ultramid® T6000

Performance between PA66 and PPA for E&E applications
 Ultramid® T6000 is a high-temperature polyamide (PA66/6T) with very good mechanical and dielectric properties in presence of humidity and at elevated temperatures. It closes the gap between BASF's polyamide and PPA offerings for E&E applications. The high-performance plastic shows good dimensional stability due to low water absorption. Ultramid® T6000 expands the coloring and design possibilities of components, as it can be colored not only in orange and grey, but also in white. Due to its high flowability, it is particularly suitable for the production of small and complex components with an electrical protective effect. The available UL cards prove excellent RTI and GWIT values. The flame retardant used is non-halogenated.

For more information, see the Ultramid® T6000 Flyer.

Ultramid® T7000

Ultramid® T7000 outperforms PA66 in mechanical properties in dry state and especially in presence of humidity up to a temperature of 80 °C. The unique combination of properties of this PA/PPA blend is perfectly suited for metal replacement. The material has a high stiffness and strength. The polyphthalamide part leads to a low moisture absorption, which gives the components an excellent dimensional stability. It is easily processable for injection molding with an excellent surface finish.

Ultramid® S Balance

As a long-chain polyamide, Ultramid® S Balance has the following properties:

- Good hydrolysis resistance
- High stress cracking resistance
- Low water absorption, high dimensional stability
- Mechanical properties largely independent of the level of conditioning
- Partly biobased

Among long-chain polyamides, Ultramid® S Balance has one of the highest level of rigidity and strength. This makes it the material of choice in areas that require a combination of resistance to media and the mechanical properties of conventional materials like PA6 and PA66.

Mechanical properties

The lower water absorption of Ultramid® S Balance compared to PA6 or PA66 results in constant mechanical properties under changing climatic conditions. Furthermore, Ultramid® S Balance has a higher heat-aging resistance compared to PA12 and thus offers a balanced range of properties for a variety of applications.

Chemical and hydrolysis resistance

Like all polyamides, Ultramid® S Balance shows excellent chemical resistance. In addition, this material also offers a number of other advantages, e.g. increased hydrolysis resistance compared with PA6 or PA66 (Fig. 7).



Fuel pressure sensor

This makes Ultramid® S Balance the perfect material for plug-in connectors, pipes and vessels in cooling circuits. The material can also be used in fuel applications, such as quick connectors.

Stress cracking resistance due to the presence of zinc chloride is an important requirement for car exteriors. Due to their inherent molecular structure, long-chain polyamides have a clear advantage. For instance, glass-fiber reinforced Ultramid® S Balance meets the conditions of the standards SAE 2644 and FMVSS 106. This means that the material is particularly suited to the overmolding of metal and electronic components that come into contact with aggressive media, e.g. wheel speed sensors.

Ultramid® S is also used in high-quality sports and leisure equipment. The portfolio includes high-impact products (S3Z4 and S3Z5) which are particularly suitable for ski boots. Compared to other materials in this segment, Ultramid® S has a very low density (1000g/l) and excellent material properties.

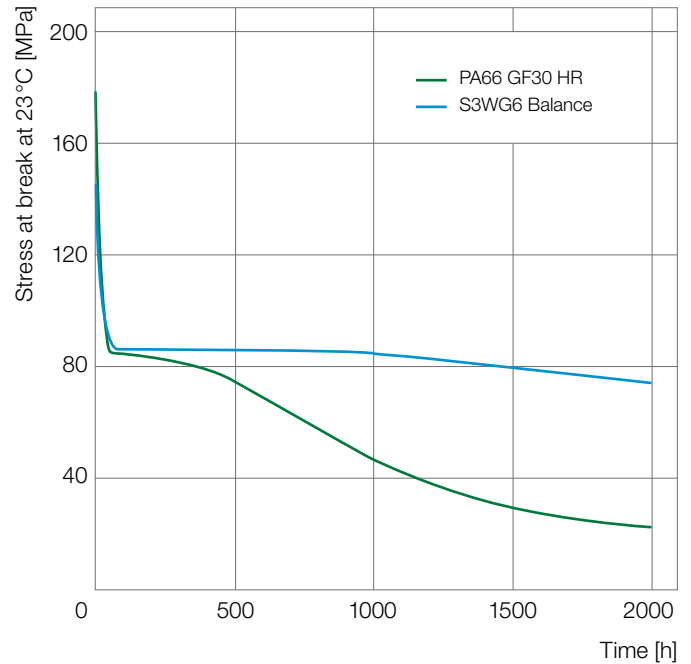

Fig. 7: Hydrolysis resistance of Ultramid® S Balance compared with PA66, in Glystantin®/water (1:1) at 130 °C

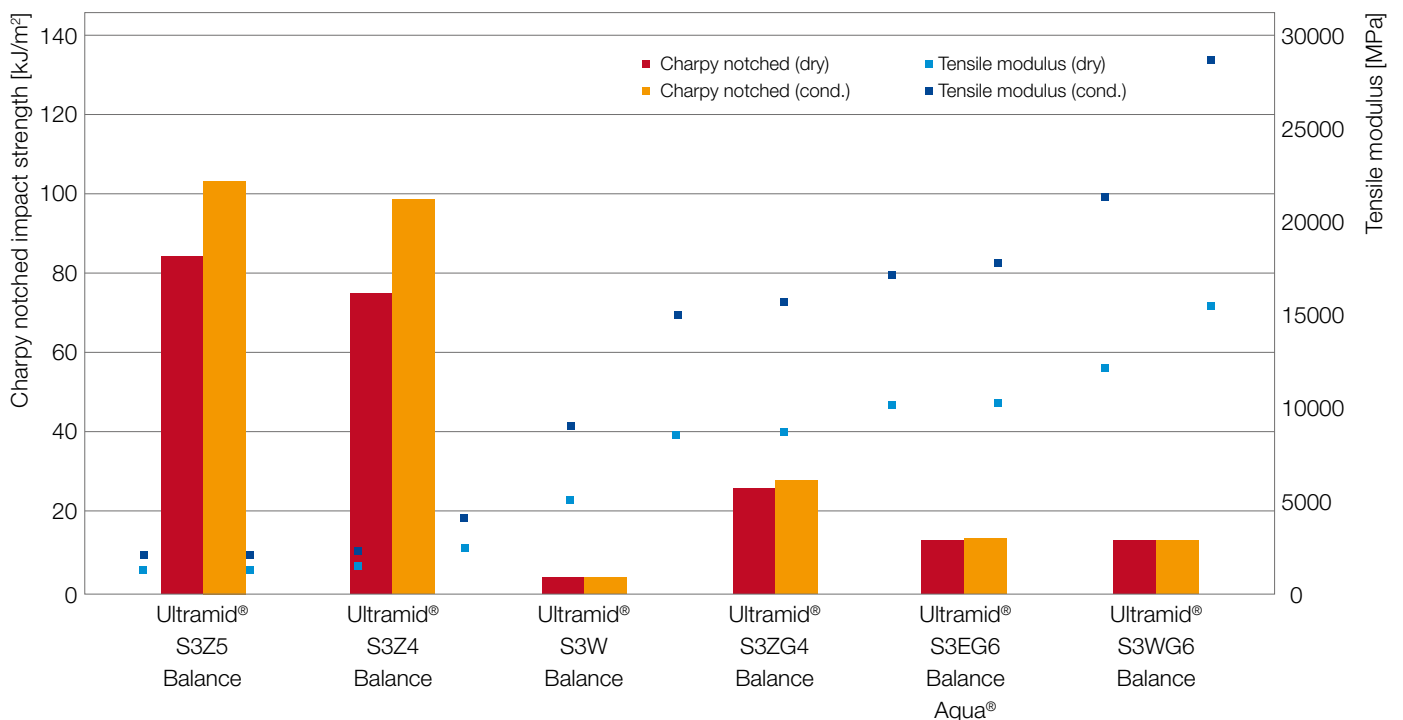

Fig. 8: Stiffness and toughness of Ultramid® S grades

Ultramid® Expand

Ultramid® Expand is an innovative particle foam based on Polyamide 6. The material consists of pre-foamed particles with defined size and density, which can be processed into complex 3D components – entirely without any chemical reaction in the foam. The result is components with isotropic properties, meaning uniform mechanical performance in all directions.

Thanks to its closed-cell structure, Ultramid® Expand offers exceptionally high compressive strength – a key requirement for crash-relevant applications with high mechanical loads. At the same time, the foam impresses with its high temperature resistance (permanently up to 150 °C, temporarily up to 190 °C) as well as its excellent chemical resistance to fuels, oils, and lubricants.

The combination of high stiffness, strength, and thermal stability makes Ultramid® Expand the ideal solution for demanding lightweight construction applications.

In addition, the material can be processed on conventional EPP molding machines as well as with modern steam-free technologies.

Overmolding with PA injection-molding compounds is also possible, allowing for hybrid components with maximum design freedom.

Ultramid® Expand is laser-markable, recyclable, and fully simulative with BASF Ultrasim® – enabling quick, efficient, and precise product development.



Ultramid® Expand demonstrator for battery cell holders



Pre-foamed Ultramid® Expand particles

Ultramid® HPP

With Ultramid® HPP (High Productivity Plus), BASF introduces a new generation of PA6-GF30, specifically designed for the highest demands in productivity and energy efficiency in injection-molding. The material impresses with:

- Excellent flowability for complex geometries
- Fast crystallization for shorter cycle times
- Processing at lower melt temperatures, which reduces energy consumption
- Lower injection pressure, minimizing wear on machines and extending the lifespan of tools

High Productivity Plus is the answer to the increasing demands for sustainable and economically efficient manufacturing processes. Initial applications demonstrate a cycle time reduction of up to 30 % – a significant productivity boost for modern plastic processors. Overall, Ultramid® HPP makes a substantial contribution to resource conservation and sustainable production – without compromising on performance and quality.



Connectors made from Ultramid® HPP



The properties of Ultramid®

Mechanical properties

The Ultramid® A (PA66) and Ultramid® B (PA6) grades, which are described here offer various combinations of mechanical properties and thus meet a variety of requirements, for example from the E & E and automotive industries as well as from numerous other sectors.

Special about polyamide as a material is its ideal combination of strength, rigidity and toughness together with excellent longevity across a wide temperature range. These advantages can be attributed to the partially crystalline structure of the polyamide: strong hydrogen bonds between molecules give strength to the crystalline areas and allow high operating temperatures, while more flexible molecule chains in the amorphous regions ensure exceptional toughness.

When choosing materials on the basis of key mechanical data, one special feature of the polyamide must be taken into account: freshly molded components are always dry and will absorb moisture depending on the ambient conditions.

This leads to a significant change in key mechanical properties, particularly in typical test conditions of 23 °C. This is why in the data sheets a distinction is frequently made between the key material data “dry” and “conditioned”.

Fig. 10 shows unreinforced Ultramid® A3K to demonstrate the influence of conditioning on the tensile modulus (shift in the glass transition temperature). With Ultramid® A3EG10, a 50 % glass fiber-reinforced product, moisture absorption is reduced (compared to an unreinforced grade). Since the storage of water only takes place in the polyamide and not in the glass fiber portion of the product, moisture absorption is lower in relation to the entire compound.

In the following part, the mechanical properties of the Ultramid® range are described on the basis of dry test specimens.

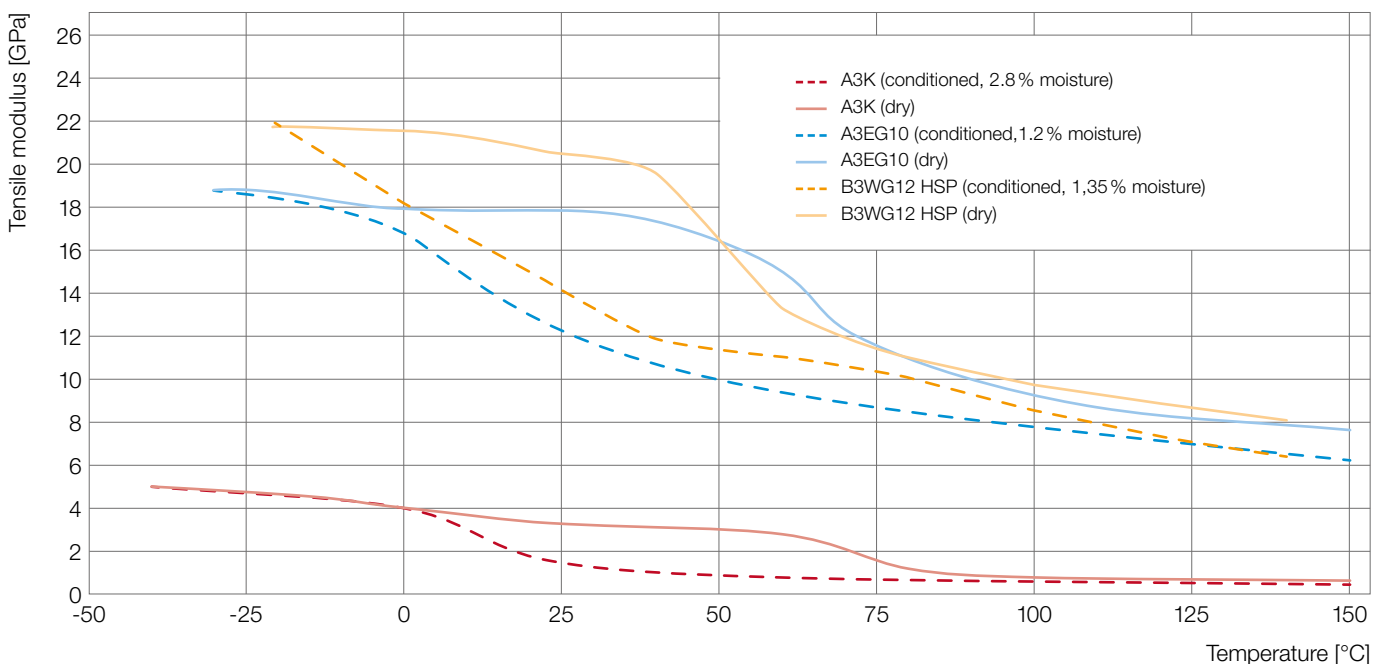

Fig. 10: Tensile modulus for selected Ultramid® grades as function of temperature and conditioning

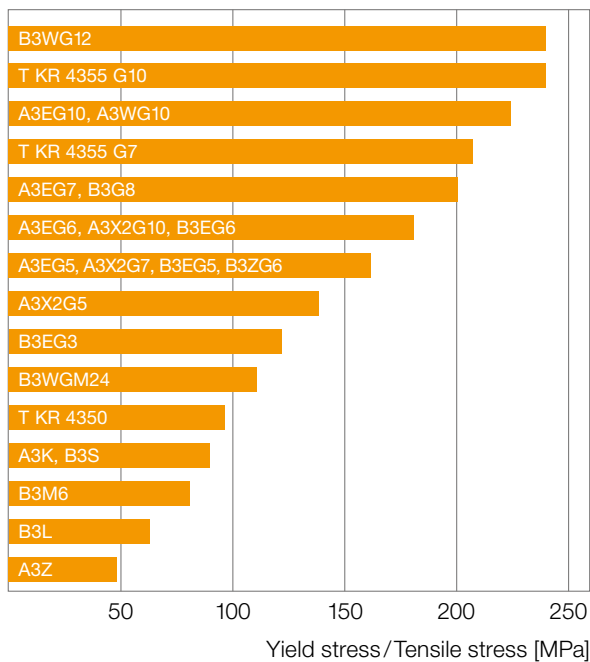

Fig. 11: Yield stress (tensile stress in the case of reinforced grades) for selected Ultramid® grades at 23 °C, dry (ISO 527)

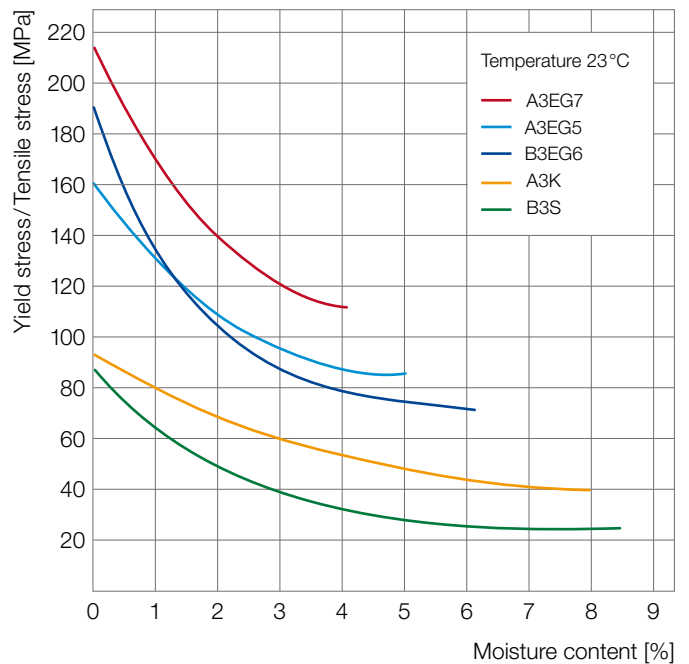

Fig. 13: Tensile stress (yield stress in the case of unreinforced grades) for Ultramid® grades as a function of moisture content at 23 °C (ISO 527)

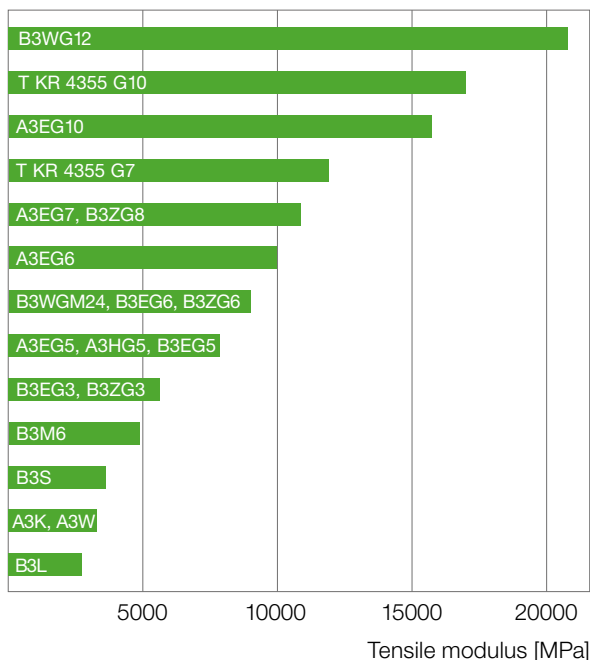

Fig. 12: Tensile modulus for selected Ultramid® grades at 23 °C, dry (ISO 527)

The product range can be divided into six groups according to the range of the modulus of elasticity (dry):

- Impact-modified unreinforced grades 1500 - 2000 MPa
- Unreinforced grades 2700 - 3500 MPa
- Mineral-filled, impact-modified grades (+GF) 3800 - 4600 MPa
- Mineral-filled grades (+GF) 3800 - 9300 MPa
- Impact-modified, glass-fiber reinforced grades 5200 - 11200 MPa
- Glass-fiber reinforced grades 5200 - 21100 MPa

The mechanical properties depend on various factors like testing temperature, moisture content, storage time (post-crystallization) and the molding conditions of the respective test specimens.

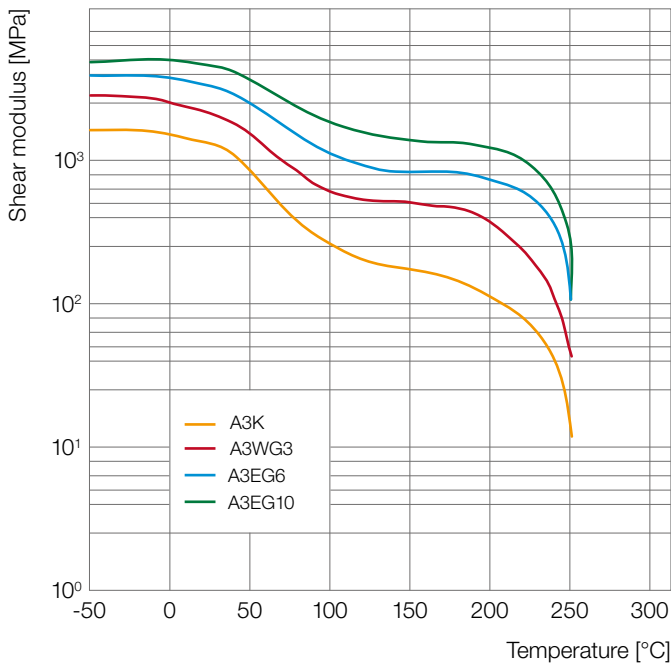

Fig. 14: Shear modulus of Ultramid® A grades as a function of temperature and glass fiber content according to ISO 6721-2, dry

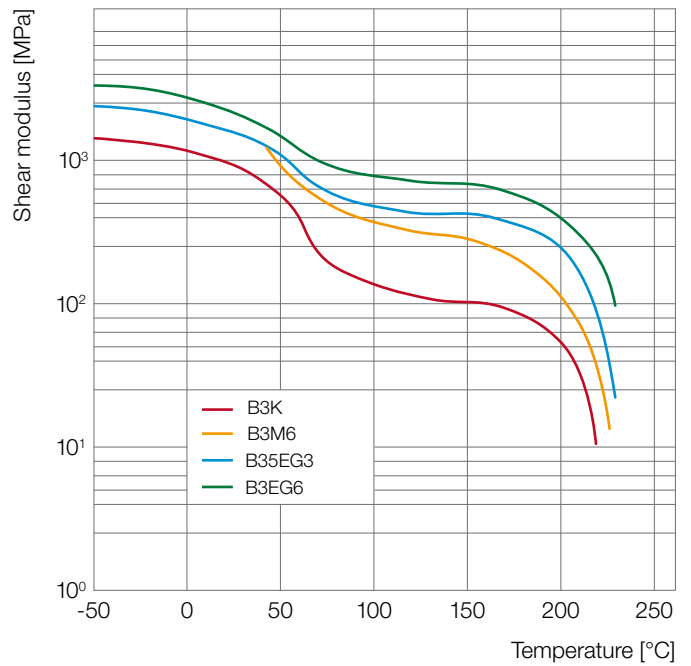

Fig. 15: Shear modulus of Ultramid® B grades as a function of temperature and filler, according to ISO 6721-2, dry

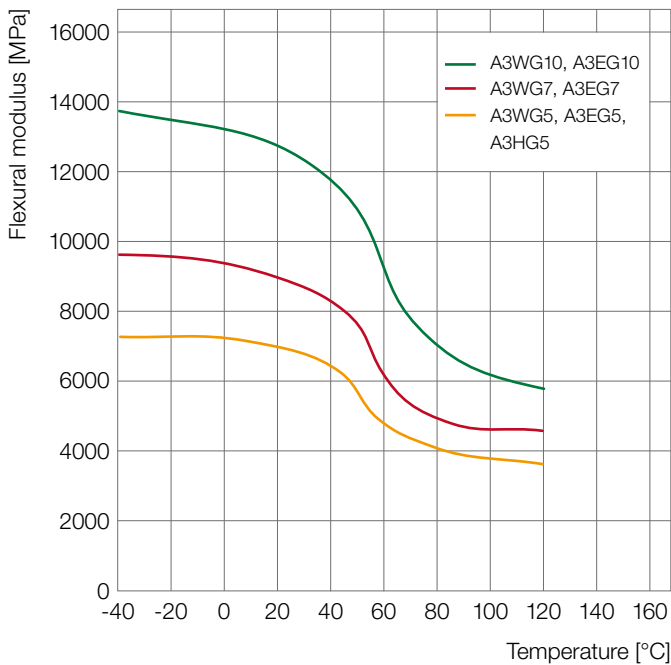

Fig. 16: Flexural modulus of reinforced Ultramid® A grades as a function of temperature (ISO 178 flexural strength test, dry)

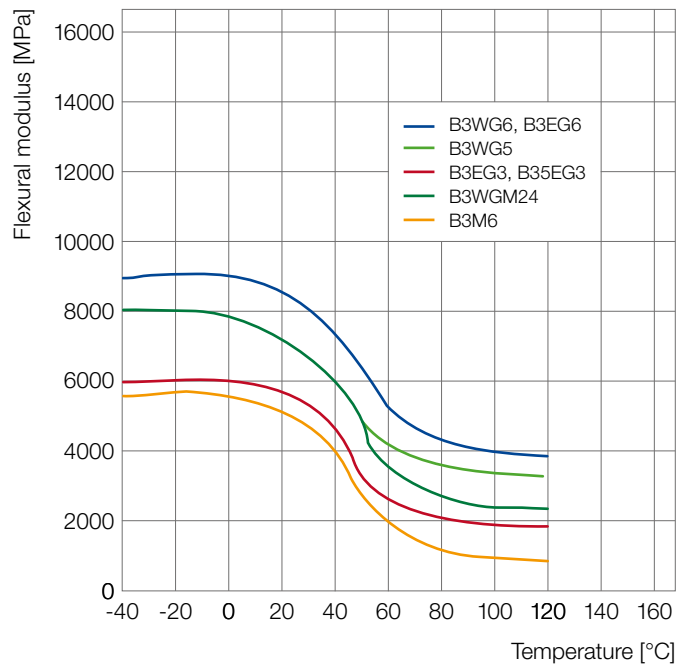

Fig. 17: Flexural modulus of reinforced Ultramid® B grades as a function of temperature (ISO 178 flexural strength test, dry)

In the case of the reinforced grades, the specific filler has a pronounced influence on the properties. The most important modification is the reinforcement with glass fibers. Influencing factors are: glass fiber content, average glass fiber length, glass fiber length distribution and the glass fiber orientation. The latter is caused by the flow process of the melt and results in anisotropic material properties. These effects can be calculated quantitatively with the BASF simulation tool Ultrasm® for the purpose of optimizing part design.

The behavior under short-term uniaxial tensile stress is shown as a stress strain diagram (Fig. 18 and 19), which illustrates the influence of temperature and reinforcement. The values shown originate from uncolored products and may be influenced by coloring. The yield stress of unreinforced Ultramid® ranges from 70 to 100 MPa while the stress at break for reinforced grades reaches up to 250 MPa.

Impact strength, low-temperature impact strength

Polyamides are very tough materials. They are suitable for parts required to exhibit high resistance to fracture. Standard test values generally determined under different conditions are used to characterize their impact behavior (see the Ultramid® product range).

Although the values are not directly comparable with one another due to the differing test setups, test specimen dimensions and notch shapes, they do allow comparison of molding materials within the individual product groups. Tests on finished parts are indispensable for the practical assessment of impact behavior. However, the behavior of Ultramid® grades when subjected to impact is affected by many factors, of which the most important are the shape of the part, the rigidity of the material and the moisture content.

The Ultramid® portfolio offers grades with different combinations of impact strength and rigidity. Depending on application, requirements, design and processing, products which are unreinforced, of relatively high molecular weight, glass-fiber reinforced, mineral-filled or impact modified can be selected, each having an optimum relationship between impact strength and rigidity.

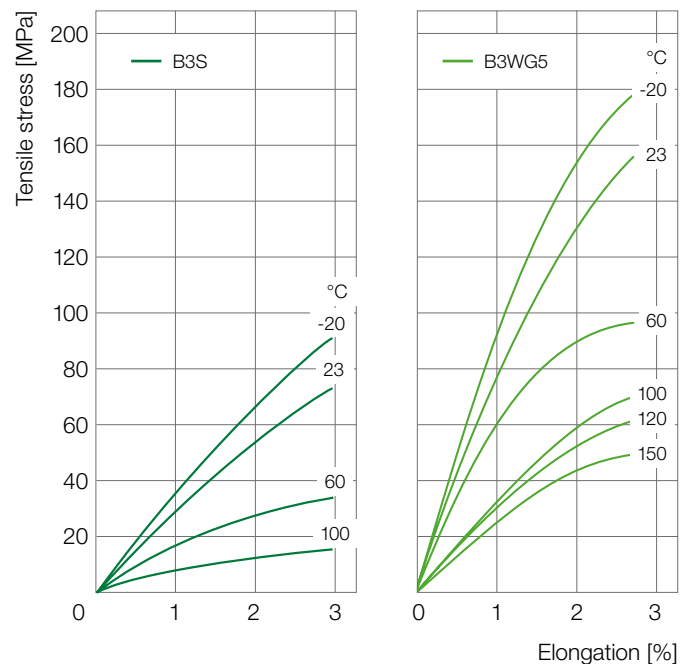

Fig. 18: Stress-strain diagrams for Ultramid® B3S and B3WG5 (dry) in accordance with ISO 527

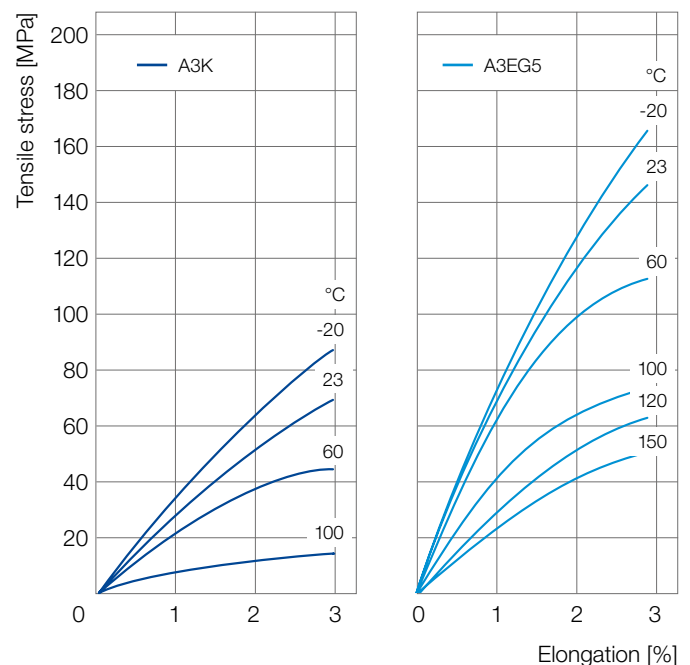

Fig. 19: Stress-strain diagrams for Ultramid® A3K and A3EG5 (dry) in accordance with ISO 527

Moisture promotes the toughness of Ultramid®. While unreinforced polyamides have a very high impact strength (typically, there is no breakage of the corresponding test specimens in an impact bending test), the impact strength initially decreases sharply with the addition of glass fibers and passes through a minimum with a glass fiber content of about 10-15 wt. % and then increases significantly again with increasing glass fiber content. In contrast, in the case of glass fiber reinforced grades, the elongation at break of finished parts in tensile tests decreases steadily with increasing glass fiber content, while at the same time the values of strength, stiffness and notched impact strength of standard test specimens increase. This effect is mainly due to the pronounced glass fiber orientation in the test specimens.

Unreinforced products of high molecular weight have proved to be effective for thick-walled engineering parts required to exhibit high impact strength.

Even in the dry state the impact-modified, unreinforced Ultramid® grades like B3L exhibit high impact strength. They are employed when conditioning or intermediate storage for absorption of moisture are uneconomic or when extremely high notched or low-temperature impact strength are required.

Apart from the particular processing conditions, the geometry of the molded part – with the resultant moments of resistance – and especially the wall thicknesses and the notch radii also play a major role in determining the fracture energy. Even the speed and point of impact significantly affect the results.

Behavior under long-term static loading

The static loading of a material for relatively long periods is caused by a constant stress or strain. The tensile creep test in accordance with ISO 899 and the stress relaxation test in accordance with DIN 53441 provide information about extension, mechanical strength and stress relaxation behavior under sustained loading.

The results are presented as creep curves, creep modulus curves, creep stress curves and isochronous stress-strain curves (Figs. 15 and 16). The curves shown here are obtained at standard atmosphere according to ISO 291 and 120 °C and represent only a selection of the results from our comprehensive investigations.

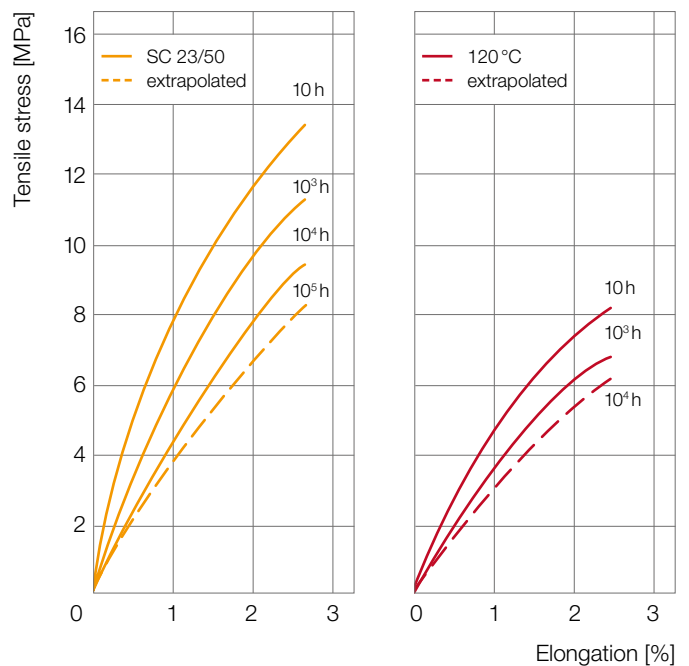

Fig. 20: Isochronous stress-strain curves for Ultramid® A3K in accordance with ISO 899 under standard climate conditions (23 °C/50 % r.h.) and at 120 °C (in the dry state)

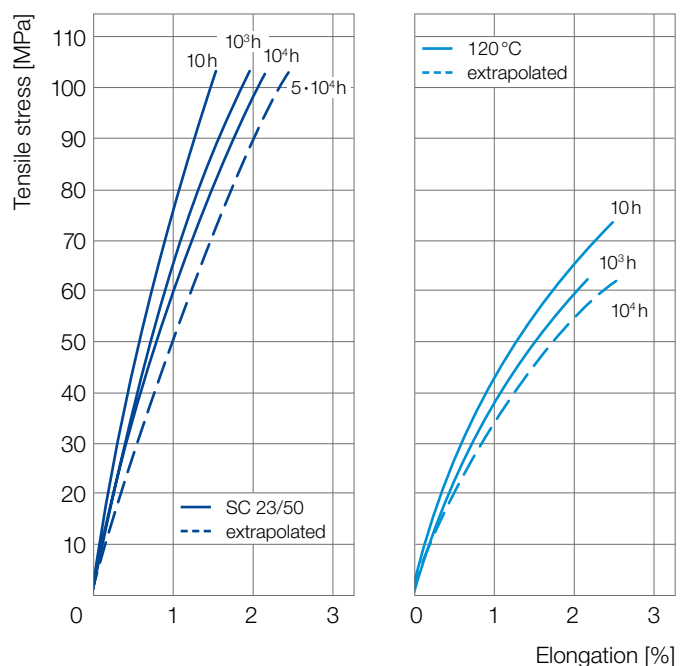

Fig. 21: Isochronous stress-strain curves for Ultramid® A3WG10 in accordance with ISO 899 under standard climate conditions (23 °C/50 % r.h.) and at 120 °C (in the dry state)

Further values and diagrams for different temperatures and climate conditions can be requested from the Ultra-Infopoint or in the program "Campus". Data obtained from uniaxial tensile loads can also be used to assess the behavior of a material under multiaxial loads. Especially reinforced grades are noted for their high creep rupture strength and low tendency to creep. Further values and diagrams for other temperature and climate conditions can be requested from the Ultra-Infopoint or taken from the "Campus" program.

Behavior under cyclic loads, flexural fatigue strength

Engineering parts are also frequently subjected to stress by dynamic forces, especially alternating or cyclic loads, which act periodically in the same manner on the structural part. The behavior of a material under such loads is determined in long-term tests using tensile and compressive loading alternating up to very high load-cycle rates. The results are presented in Woehler diagrams, obtained by plotting the applied stress against the load-cycle rate achieved in each case (Fig. 18). When transferring the test results in practice, it has to be taken into account that at high cycle fatigue frequencies the test specimen may heat up considerably due to internal friction. In such cases it may make sense to apply a higher testing temperature. (Fig. 22).

Tribological behavior

The smooth, tough and hard surface, partially crystalline structure, high thermostability and resistance to lubricants, fuels and solvents make Ultramid® an ideal material for parts subjected to sliding friction. Whereas metallic materials tend to jam under dry-running conditions, pairings with Ultramid® run satisfactorily in most cases without lubrication.

Wear and friction are system properties which depend on many parameters, e.g. on the paired materials, surface texture and geometry of the sliding parts in contact, the intermediate medium (lubricant) and the stresses due to external factors such as pressure, speed and temperature.

The most important factors determining the level of wear due friction and the magnitude of the coefficient of sliding friction of Ultramid® are the hardness and surface roughness of the paired materials, the contact pressure, the distance traversed, the temperature of the sliding surfaces and the lubrication. Further information can be found in the Technical Information "Friction and wear of polymer materials".

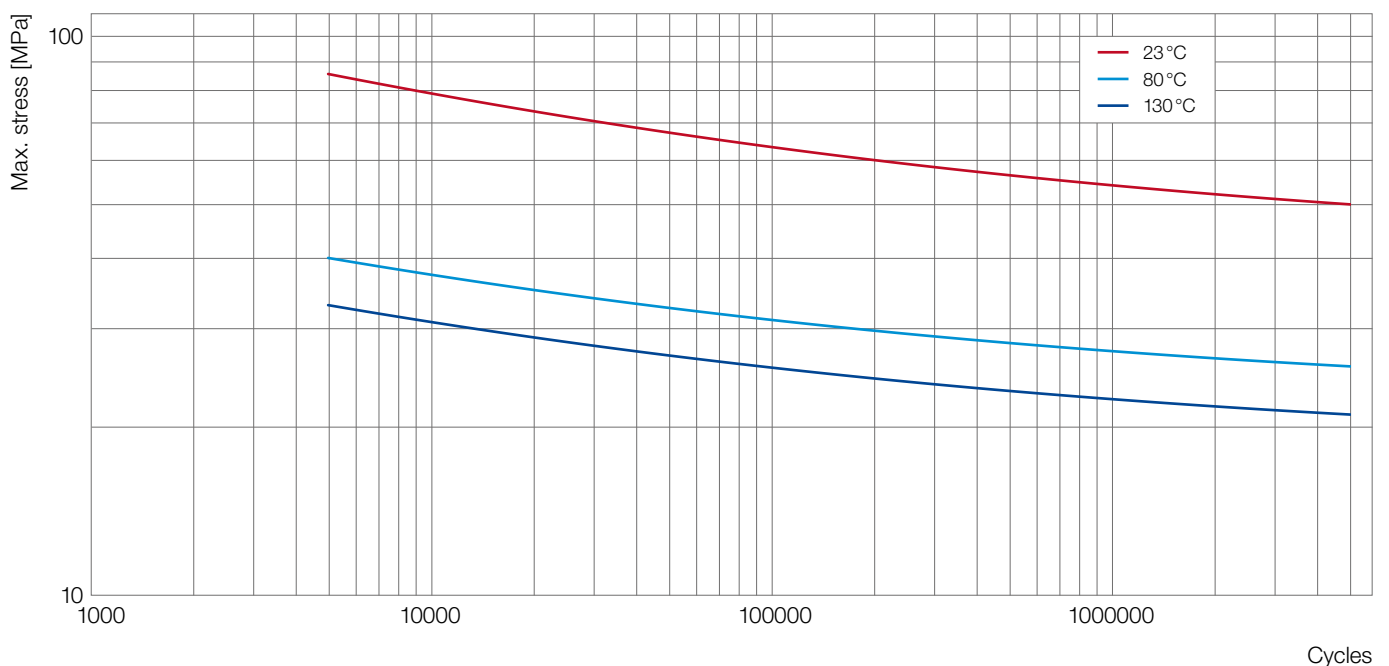

Fig. 22: Fatigue of Ultramid® A3WG7 at different temperatures (dry, R = -1, 10Hz, lengthwise oriented, thickness = 3mm)

Thermal properties

Ultramid® has the following melting temperatures:

| | |
|---------------------------|--------|
| Ultramid® A: | 260 °C |
| Ultramid® B: | 220 °C |
| Ultramid® C: | 242 °C |
| Ultramid® S: | 222 °C |
| Ultramid® T KR: | 295 °C |
| Ultramid® Advanced T1000: | 325 °C |
| Ultramid® Advanced T2000: | 310 °C |
| Ultramid® Advanced N: | 300 °C |
| Ultramid® T6000: | 280 °C |
| Ultramid® T7000: | 260 °C |
| Ultramid® F: | 196 °C |
| Ultramid® Expand: | 220 °C |

Due to its semicrystalline structure and strong hydrogen bonding Ultramid® retains its shape even at elevated temperatures close to the melting range.

Ultramid® stands out among other partially crystalline thermoplastics due to its low coefficients of linear expansion.

The reinforced grades in particular exhibit high dimensional stability when exposed to temperature changes. In the case of the glass-fiber reinforced grades, however, linear expansion depends on the orientation of the fibers.

Behavior on heat

Apart from its product-specific thermal properties the behavior of components made from Ultramid® on exposure to heat depend on many factors: Exposure time, the specific source of thermal stress and mechanical load at elevated temperature. The design of the parts also has an effect. Accordingly, the thermostability of Ultramid® parts cannot be estimated simply on the basis of the temperature values from the various standardized tests no matter how valuable the latter might be for guidance and comparisons.

The shear modulus and damping values measured as a function of temperature in torsion pendulum tests in accordance with ISO 6721-2 afford valuable insight into the temperature behavior. Comparison of the shear modulus curves (Fig. 14 and 15) provides information about the different thermomechanical effects at low deformation stress and speed. Based on practical experience, the thermostability of parts produced in optimum manner is in good agreement with the temperature ranges determined in the torsion tests in which the start of softening becomes apparent.

The test for heat resistance in accordance with IEC 60695-10-2 (ball indentation test), is usually specified for applications in electrical equipment. All Ultramid® grades can pass this test at 125 °C, making Ultramid® the material of choice for voltage carrying parts. Higher temperature requirements can also be met with Ultramid®. We recommend reinforced grades for this purpose.



Circuit breaker

Heat-aging resistance

Stabilized Ultramid®, which is traditionally marked with K, E, H or W as the second letter in the nomenclature, is suitable for parts subject to long periods of temperature stress. Depending on the respective application requirements, the Ultramid® portfolio covers the entire range of continuous operating temperatures: W2 stabilization is suitable for temperatures up to 190 °C. The spectrum is completed by Ultramid® Endure, which can be used up to 220 °C. Optimized products with E or H stabilization are suitable for sensitive applications, e.g. in electronics. P-stabilization completes the portfolio of heat-stabilized Ultramid® products, as it is also suitable for sensitive applications due to its absence of metal and halides, while allowing continuous use temperatures of up to 190 °C.

The adjacent figure 23 summarizes the features and effectiveness of each stabilization. The temperature ranges are given only for guidance and depend on the particular product. The tensile strength as a function of the storage time is shown in Figure 24 for a number of Ultramid® grades.

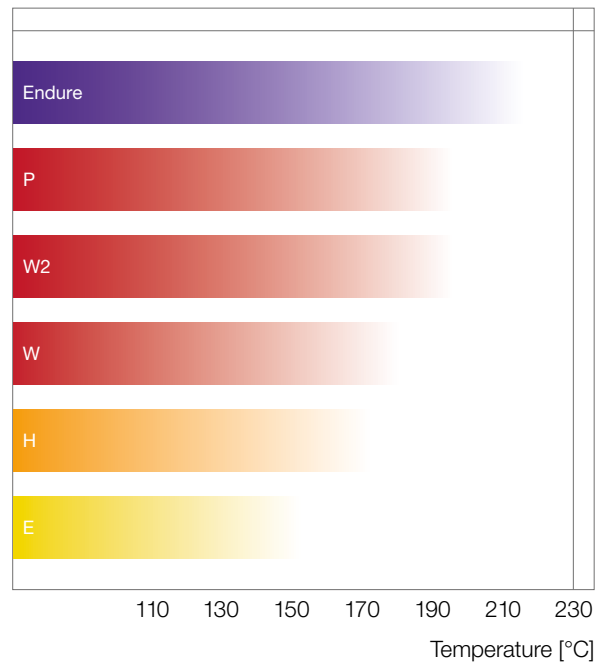

Fig. 23: Typical continuous operating temperatures (in relation to the retention of tensile strength after 3,000h) for Ultramid® grades

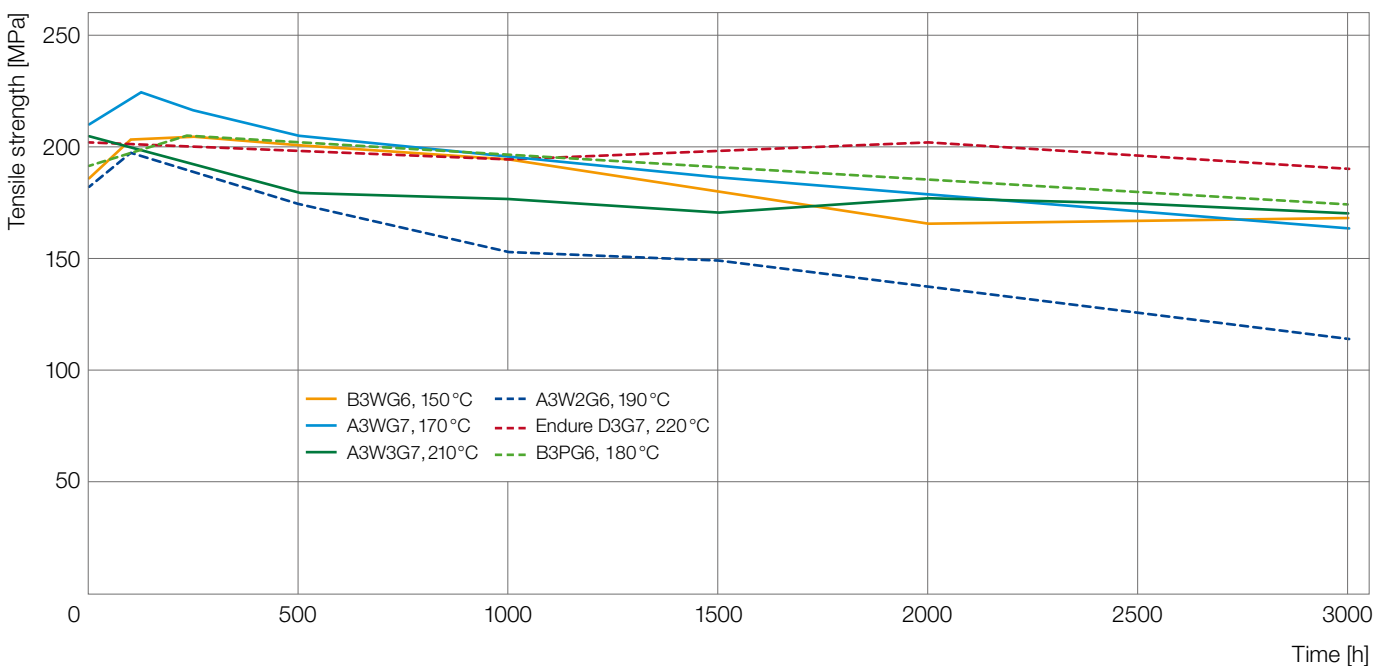

Fig. 24: Heat-aging resistance of different Ultramid® grades (tensile test at 23 °C, dry, according to ISO 527)

Heat-aging resistance in hot lubricants, coolants and solvents

The widespread application of Ultramid® in engineering, especially in automotive applications, e.g. in engine oil circuits and gearboxes, is based on its outstanding long-term resistance to hot lubricants, fuels, coolants and to solvents and cleaning agents. Figures 25 and 26 show how the elongation at break of glass fiber-reinforced Ultramid® grades can be affected by storage in hot lubricants or coolants. For applications in automotive cooling circuits, B3HG6/7 HR and A3HG6/7 HRX have proven effective at elevated ambient temperatures.

Water absorption and dimensional stability

A special characteristic of polyamides in comparison with other thermo plastics is their water absorption. In water or in moist air depending on its relative humidity and dependant on time, temperature and wall thickness moldings absorb a certain quantity of water so that their dimensions increase slightly. The increase in weight on saturation depends on the respective Ultramid® grade and is listed in the tables in the range chart. Fig. 27 shows how the absorption of moisture on saturation depends on the relative humidity.

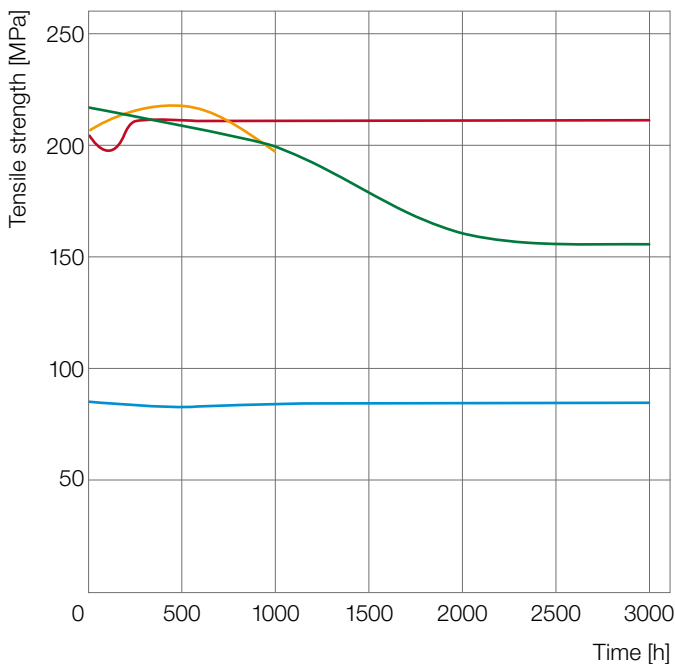

Fig. 25: Tensile strength of different Ultramid® A grades after storage in oils or lubricating greases

- A3HG7, gear oil – Pentosin FFL2, 150 °C
- A3WG7, engine oil – Aral Extra Turboral SAE 10W-40, 150 °C
- A4H, lubricating grease – Fuchs Renolit LT1, 120 °C
- A3WG7, gear oil – Dexron VI ATF2, 150 °C

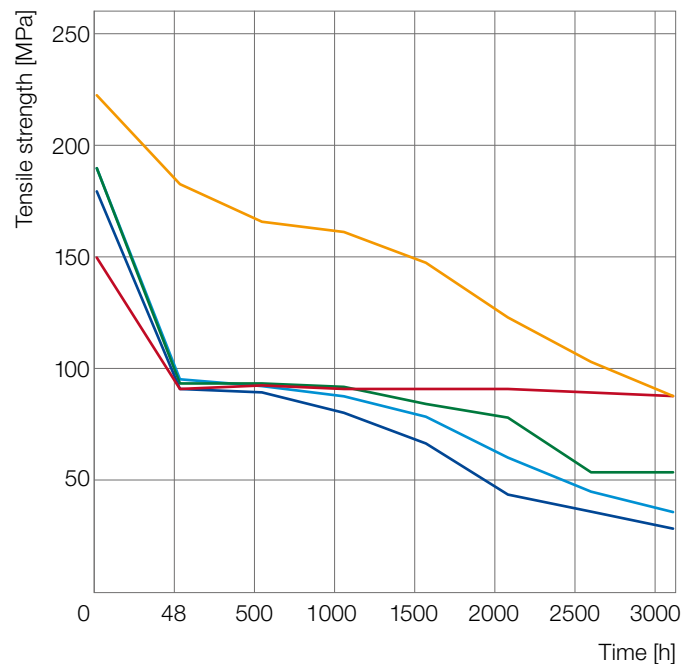

Fig. 26: Tensile strength of different Ultramid® grades after storage in Glystantin®/water 1:1

- B3HG7 HR 120 °C
- A3HG6 HR, 130 °C
- A3WG6 HRX, 130 °C
- S3WG6 Balance, 130 °C
- T1300HG7 HR

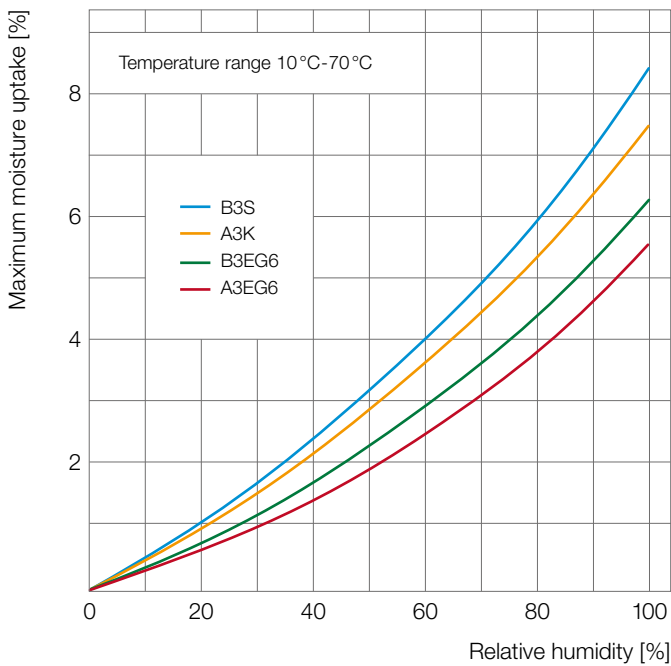

Fig. 27: Equilibrium moisture content of Ultramid® as a function of relative humidity in the temperature range 10°C-70°C (scatter: ± 0.2 to 0.4 % absolute)

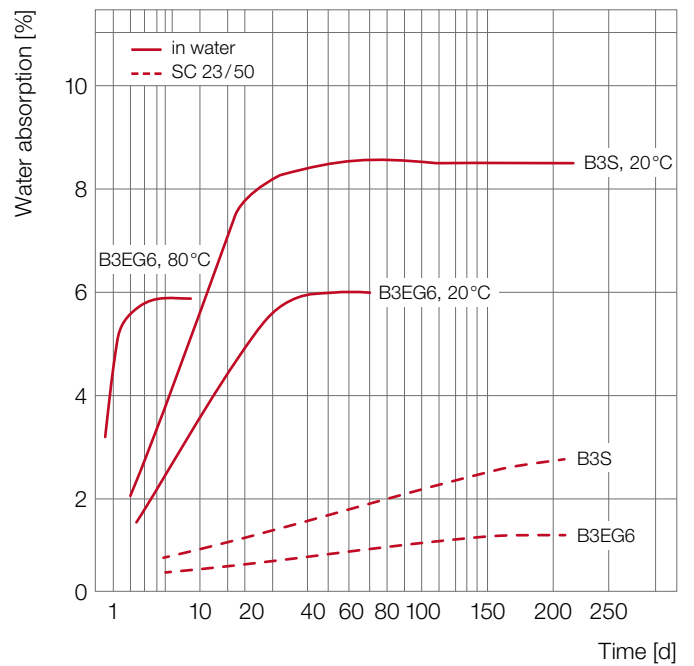

Fig. 28: Water absorption of Ultramid® B as a function of storage time and the conditioning parameters (specimen thickness 2 mm)

Figs. 28 and 29 show the water absorption of Ultramid® as a function of storage time under various test conditions.

The impact resistance, elongation at break and creep in crease with water absorption, while strength, stiffness and hardness decrease. Respective test results for different products are shown in the Ultramid® range chart or CAMPUS.

Provided that the water is uniformly distributed in the part, Ultramid® A and Ultramid® B undergo a maximum increase in volume of about 0.9% and a mean increase in length of 0.2 to 0.3% per weight percent of absorbed water. The dimensional change of the glass-fiber reinforced grades amounts to less than 0.1% in the direction of the fiber orientation (longitudinally). As a result these grades, in addition to mineral-filled grades, remain particularly constant dimensions when humidity varies.

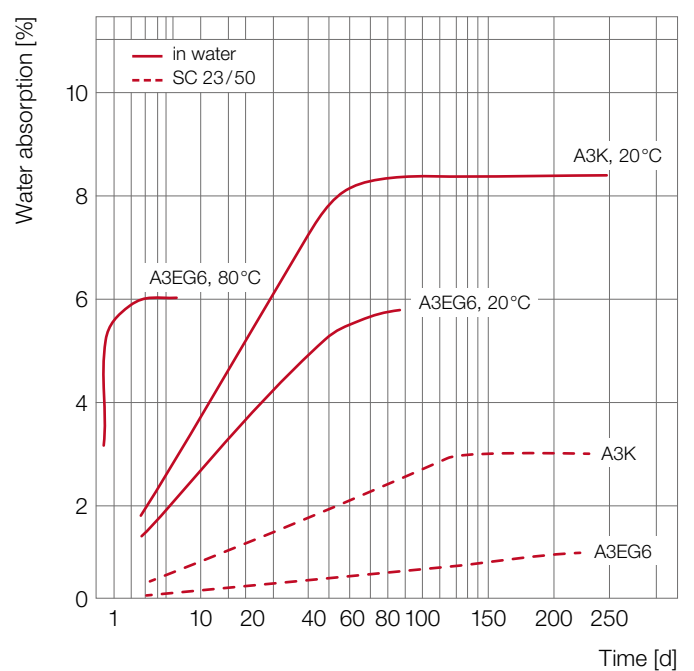

Fig. 29: Water absorption of Ultramid® A as a function of storage time and the conditioning parameters (thickness of specimen 2 mm)

Electrical properties

The paramount importance of Ultramid® in electrical engineering, especially for electrical insulating parts and housings in power engineering, is attributable to its good insulating properties (volume and surface resistance) combined with its high dielectric strength and high tracking resistance as well as its advantageous properties in relation to heat-aging. As a result, Ultramid® is numbered among the high-performance insulating materials. Flame-retardant grades are always preferred where fire behavior requirements are high.

Concerning electrical properties the following should be considered:

- The products are characterized by a high tracking current resistance which is only slightly impaired by the moisture-content of the material.
- The specific volume resistance and the surface resistance are very high; these values decline at elevated temperatures and also when the water content is relatively high.
- As for all electrical insulating materials, when used in harsh conditions, continual wetting due to condensation must be prevented by appropriate design measures.
- Unfavorable operating environments such as trapped heat combined with high air humidity, moist, warm conditions or poor ventilation can adversely affect the insulating properties.

For the above reasons, the performance of the components should be carefully checked for each application. The values of the electrical properties are listed in the range chart.

The Ultramid® range includes materials with moderate (E/K, EQ), medium (H and W) and high (P) long-term aging resistance.

Especially in sensitive applications in the field of micro-electronics, migration effects can occur in the presence of water (condensation), which in rare cases can cause damage to the electronic components.

As a result, BASF offers a portfolio of various polyamide 6 and 66 grades for particularly sensitive automotive electronics such as control units and sensors as well as HV components, that help prevent damage to circuits caused by electric corrosion. The different Ultramid® EQ grades (EQ = Electronic Quality) are characterized by extremely high purity with regard to electrically active or corrosion-promoting ingredients and still offer good resistance to heat-aging. They are subject to special quality tests that cover raw material selection, the production process, and the analysis of the halogen content. The globally available portfolio consists of uncolored and black grades with a glass fiber content of 30 % and 35 %, which are also laser-markable.

For sensitive applications requiring higher continuous service temperature resistance, either H-stabilized or P-stabilized materials can be used.

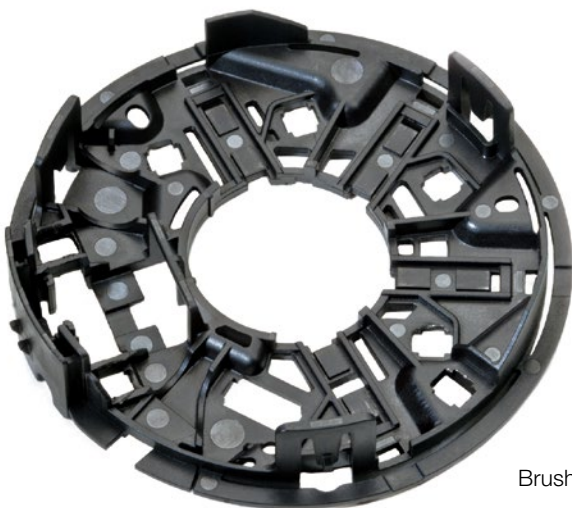

Brush holder



Connector

Figs. 30 and 31 show the effect of temperature and moisture on the dielectric strength and specific volume resistivity of Ultramid®.

For an important grade within the flame-retardant product range, i.e. Ultramid® A3X on the basis of red phosphorous, the following applies: The Ultramid® A3X grades contain a special stabilizer to prevent the formation of red phosphorous decomposition products which can occur in polyamides with phosphorus-based flame retardants. When applied as an electrical insulating material, especially when heat and humidity are an issue, approval tests and constructive measures must ensure the reliability of the final parts.



Gearbox control

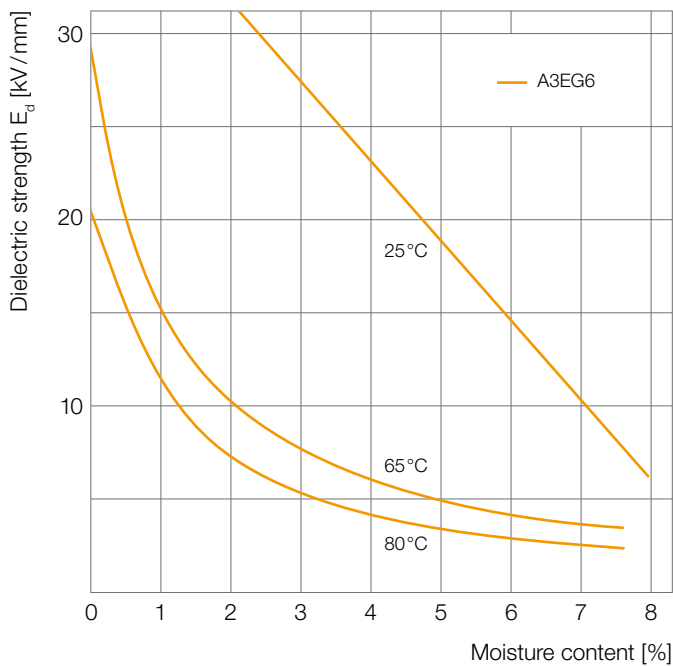

Fig. 30: Dielectric strength of Ultramid® A3EG6 at different temperatures as a function of moisture content (IEC 60243; wall thickness 3 mm)

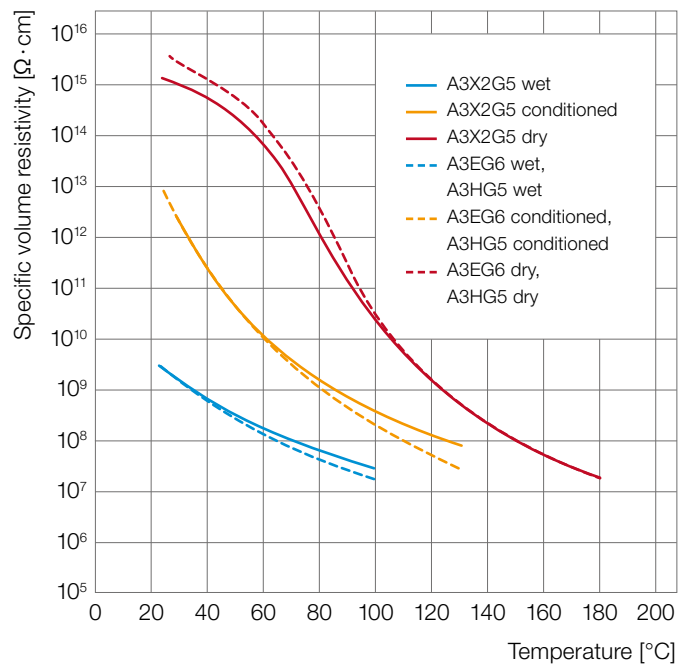

Fig. 31: Specific volume resistivity of glass-fiber reinforced Ultramid® A with different moisture contents as a function of temperature (IEC 60093)

Halogen content

The Ultramid® portfolio includes materials with moderate (E/K, EQ), medium (H and W) and high (W2 and P) long-term aging resistance. Depending on the stabilizer system, different contents of halide salts are found in the materials. In the W products, these halide salts are explicitly added as an effective and proven heat stabilizer.

In sensitive applications in the field of microelectronics, migration of halide salts can occur in the presence of water under unfavorable boundary conditions, which can initiate corrosion processes. Therefore, the low-halide heat stabilizers (E/K, H and P) are recommended for sensitive E&E applications.

For highly sensitive applications with moderate temperature exposure, BASF also offers product class EQ, whose materials are particularly low in halide and are tested during production to maintain low halide content.

For sensitive applications requiring higher continuous service temperature resistance, H-stabilized or P-stabilized materials can be used.

Fire behavior

General notes

Ultramid® products slowly start to decompose above a certain temperature. This is dependent on the composition of the particular product. Flammable gases can form, which continue to burn after ignition. These processes are influenced by many factors, so it is impossible to give a definite flash point. Flame retardant additives are used to prevent fires (ignition) or to minimize the spread of fires (self-extinguishing).

Decomposition products and combustion gases in general can be toxic. The safety data sheets contain the corresponding product-specific physical and chemical properties.

Tests

Electrical engineering

The glow wire test according to IEC 60695-2-10ff is often required in Europe (Tables 3 and 6). IEC 60335-1 also requires the GWIT 775 (IEC 60695-2-13) to be met by materials in contact with live components in unattended household appliance.

Another method based on standardized test specimens is the flammability test according to “UL94 Standard, Tests for Flammability of Plastic Materials for Parts in Devices and Appliances” of Underwriters Laboratories Inc./USA.

The unreinforced grades Ultramid® A3K R01 and B3S R03 are classified in Class UL94 V-2 according to this test procedure. The unreinforced and flame retardant C3U achieves a UL94 V-0 classification.

The glass fiber-reinforced Ultramid® grades generally require a flame retardant additive to achieve a good classification. Examples are Ultramid® A3X2G, A3U42G6, B3U42G6, B3U50G6 and Ultramid® Advanced N3U41G6. The flame retarding properties are summarized in Tables 3 and 6.

Transportation

In traffic and transport engineering, plastics contribute substantially to the high performance of road vehicles and trains. Materials used inside motor vehicles are governed by the fire safety requirements according to DIN 75200 and FMVSS 302, which are met by most Ultramid® products with a wall thickness of 1 mm and above (Table 6). The above-mentioned test methods for electrical engineering are also typical for electric powertrain applications. For rail vehicles, in addition to different national regulations, a European standard EN 45545 was established. Among other things it also contains requirements regarding side effects of fires such as the density and toxicity of smoke gases.

Construction industry

The testing of building materials for the construction industry is carried out in accordance with DIN 4102, Part 1, “Fire behavior of building materials and building parts”. Sheets of unreinforced and glass-fiber reinforced Ultramid® (thickness ≥ 1 mm) are rated as normally flammable building materials in Building Materials Class B 2 (designation in accordance with the building regulations in the Federal Republic of Germany).

| Product | UL 94, Thickness in mm | Glow wire test ¹⁾ IEC 60695 2-12 | FMVSS 302 (d>1 mm) |
|--------------------------|------------------------|--|-----------------------|
| A3K R01 | V-2, 0.4 | 960 °C ²⁾ | reached |
| B3S R03 | V-2, 0.8 | 960 °C ²⁾ | reached |
| A3EG... reinforced | HB | 650 °C | reached |
| B3EG... reinforced | HB | 650 °C | reached |
| C3U | V-0, 0.4 | 960 °C | reached |
| A3UG5 | V-0, 0.75 | 960 °C | reached |
| A3U42G6 | V-0, 0.4 | 960 °C | reached |
| A3U44G6 DC | V-0, 0.4 | 960 °C | reached |
| A3X2G5 | V-0, 0.8 | 960 °C | reached |
| A3XZG5 | V-0, 1.5 | 960 °C | reached |
| A3X2G7 | V-0, 0.75 | 960 °C | reached |
| A3X2G10 | V-0, 1.5 | 960 °C | reached |
| A3XZC3 ESD | V-0, 1.5 | 960 °C | reached |
| B3UG4 | V-2, 0.71 | 960 °C | reached |
| B3U30G6 | V-2, 0.75 | 960 °C | reached |
| B3U42G6 | V-0, 0.4 | 960 °C | reached |
| B3U50G6 | V-0, 0.8 | 960 °C | reached |
| B3UGM210 | V-0, 1.5 | 960 °C | reached |
| T KR4365 G5 | V-0, 0.75 | 960 °C | reached |
| T KR4340 G6, T KR4341 G6 | V-0, 0.4 | 960 °C | reached |
| T6340G6 | V-0, 0.4 | 960 °C | reached |
| Adv. T2340G6 | V-0, 0.4 | 960 °C | reached |
| Adv. N3U41G6 | V-0, 0.25 | 960 °C | reached |
| Adv. N3U42G6 | V-0, 0.4 | 960 °C | reached |

Table 6: Fire performance

¹⁾ Material testing conducted on sheets (thickness of 1 mm)
²⁾ Undyed; dyeing can have an influence



Generator end cap

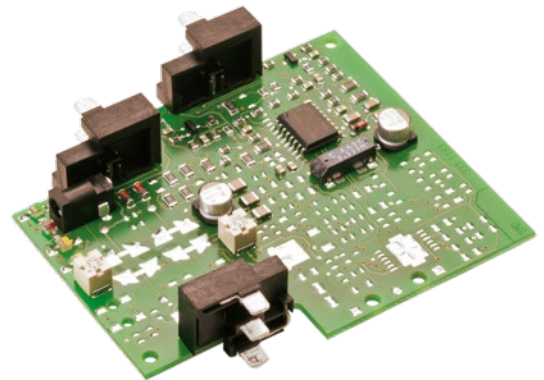

Terminal carrier

Resistance to chemicals

Polyamide shows good resistance to lubricants, fuels, hydraulic fluids and coolants, refrigerants, dyes, paints, cleaners, degreasing agents, aliphatic and aromatic hydro-carbons and many other solvents even at elevated temperatures.

Ultramid® is resistant to corrosion, to aqueous solutions of many inorganic chemicals (salts, alkalis). Special mention should be made of its outstanding resistance against stress-crack formation compared to many amorphous plastics. Many media such as, for instance, wetting agents, ethereal oils, alcohols and other organic solvents do not detrimentally affect the creep behavior of polyamide.

Good resistance to chemicals is an important prerequisite for the use of Ultramid® in automotive, aerospace and chemical engineering.

Ultramid® is not resistant to concentrated mineral acids. The same applies to certain oxidants and chlorinated hydrocarbons, especially at elevated temperatures. Attention should also be given to its sensitivity to certain heavy-metal salt solutions such as, for example, zinc chloride solution. The semi-aromatic chemical structure of Ultramid® Advanced (PPA) makes those products particularly resistant to moisture and aggressive media.

Table 7 summarizes Ultramid®'s resistance to the most important chemicals. Further information on the effect of solvents and chemicals can be found on the Internet at www.plastics.basf.com.



Thermostat housing

The consequences of exposing a polymeric material to various types of media can depend on many factors that sometimes interact in a complex way. Consequently, testing a component under realistic circumstances and under typical application conditions always gives the most meaningful results on whether a material is suited for a given application or not. In contrast, when it comes to laboratory tests, simple test specimens are often exposed to a medium under well-defined and constant conditions. Such experiments allow a relative comparison between different materials and thus lay the foundation for pre-selecting potential candidates as the right material for a given application. However, these experiments cannot substitute actual-practice testing.

Before selecting a material, especially for components subject to high stresses and possible exposure to corrosive chemicals, its chemical suitability should be verified. This may be done on the basis of experience with similar parts made of the same material in the same medium under comparable conditions or by testing parts under practical conditions.



Oil sensor



Oil pan

| | Ultramid® A | Examples | Ultramid® B |
|---|------------------------------------|--|------------------------------------|
| Highly resistant: empirical value from numerous applications under their typical conditions | aliphatic hydrocarbons | natural gas, fuels (Otto, diesel), paraffin oil, motor oils, technical greases and lubricants | aliphatic hydrocarbons |
| | aromatic hydrocarbons | benzene, toluene | aromatic hydrocarbons |
| | alkalis | ordinary soap, washing solutions, alkaline concrete | alkalis |
| | ethers | THF, antiknock agents for fuels (TBME, ETBE) | ethers |
| | esters | greases, cooking oils, motor oils, surfactants | esters |
| | aliphatic alcohols | <60°C ethanol, methanol, isopropanol, anti-freeze agents for windshield washing systems, spirits, fuels (E10, E50, E90) | aliphatic alcohols |
| | water and aqueous solutions | drinking water, seawater, beverages | water and aqueous solutions |
| | organic acids | in the solid state: citric acid, benzoic acid | organic acids |
| Somewhat resistant: known applications, thorough testing and case-to-case evaluations necessary | alkalis | sodium hydroxide solution, ammonia solution, urea solution, amines | alkalis |
| | ethylene glycol | >80°C coolants | ethylene glycol |
| | esters | transmission oils, biodiesel | esters |
| | aliphatic alcohols | >60°C ethanol, methanol, isopropanol, anti-freeze agents for windshield washing systems, spirits, fuels | aliphatic alcohols |
| | water and aqueous solutions | >80°C chlorinated drinking water | water and aqueous solutions |
| | organic acids | as an aqueous solution: acetic acid, citric acid, formic acid, benzoic acid | organic acids |
| | oxidants | traces of ozone, chlorine or nitrous gases | oxidants |

Table 7: Overview of the media resistance of Ultramid® (discoloration of the test specimens is not taken into consideration during the evaluation of the resistance)

| Examples | Ultramid® S | Examples | Ultramid® Advanced (PPA) | Examples |
|---|------------------------------------|---|------------------------------------|---|
| natural gas, fuels (Otto, diesel), paraffin oil, motor oils, technical greases and lubricants | aliphatic hydrocarbons | natural gas, fuels (Otto, diesel), paraffin oil, motor oils, technical greases and lubricants | aliphatic hydrocarbons | natural gas, fuels (Otto, diesel), paraffin oil, motor oils, technical greases and lubricants |
| benzene, toluene | aromatic hydrocarbons | benzene, toluene | aromatic hydrocarbons | benzene, toluene |
| ordinary soap, washing solutions, alkaline concrete | alkalis | ordinary soap, washing solutions, alkaline concrete | alkalis | ordinary soap, washing solutions, alkaline concrete |
| | ethylene glycol | brake fluids, hydraulic fluids, coolants | ethylene glycol | brake fluids, hydraulic fluids, coolants |
| THF, antiknock agents for fuels (TBME, ETBE) | ethers | THF, antiknock agents for fuels (TBME, ETBE) | ethers | THF, antiknock agents for fuels (TBME, ETBE) |
| greases, cooking oils, motor oils, surfactants | esters | greases, cooking oils, motor oils, surfactants | esters | greases, cooking oils, motor oils, surfactants |
| <60°C ethanol, methanol, isopropanol, anti-freeze agents for windshield washing systems, spirits, fuels (E10, E50, E90) | aliphatic alcohols | <60°C ethanol, methanol, isopropanol, anti-freeze agents for windshield washing systems, spirits, fuels (E10, E50, E90) | aliphatic alcohols | <60°C ethanol, methanol, isopropanol, anti-freeze agents for windshield washing systems, spirits, fuels (E10, E50, E90) |
| drinking water, seawater, beverages | water and aqueous solutions | drinking water, seawater, beverages | water and aqueous solutions | drinking water, seawater, beverages |
| in the solid state: citric acid, benzoic acid | organic acids | in the solid state: citric acid, benzoic acid | organic acids | in the solid state: citric acid, benzoic acid |
| ozone as a component of air | oxidants | ozone as a component of air | oxidants | ozone as a component of air |
| sodium hydroxide solution, ammonia solution, urea solution, amines | alkalis | sodium hydroxide solution, ammonia solution, urea solution, amines | alkalis | sodium hydroxide solution, ammonia solution, urea solution, amines |
| >80°C coolants | ethylene glycol | >80°C coolants | ethylene glycol | >80°C coolants |
| transmission oils, biodiesel | esters | transmission oils, biodiesel | esters | transmission oils, biodiesel |
| >60°C ethanol, methanol, isopropanol, anti-freeze agents for windshield washing systems, spirits, fuels | aliphatic alcohols | >60°C ethanol, methanol, isopropanol, anti-freeze agents for windshield washing systems, spirits, fuels | aliphatic alcohols | >60°C ethanol, methanol, isopropanol, anti-freeze agents for windshield washing systems, spirits, fuels |
| >80°C chlorinated drinking water | water and aqueous solutions | >80°C chlorinated drinking water | water and aqueous solutions | >80°C chlorinated drinking water |
| as an aqueous solution: acetic acid, citric acid, formic acid, benzoic acid | organic acids | as an aqueous solution: acetic acid, citric acid, formic acid, benzoic acid | organic acids | as an aqueous solution: acetic acid, citric acid, formic acid, benzoic acid |
| traces of ozone, chlorine or nitrous gases | oxidants | traces of ozone, chlorine or nitrous gases | oxidants | traces of ozone, chlorine or nitrous gases |

| | Ultramid® A | Examples | Ultramid® B |
|--------------------------|------------------------------------|--|------------------------------------|
| Not resistant | mineral acids | concentrated hydrochloric acid, battery acid, sulfuric acid, nitric acid | mineral acids |
| | oxidants | halogens, oleum, hydrogen peroxide, ozone, hypochlorite | oxidants |
| Triggers stress cracking | aqueous calcium chloride solutions | road salt | aqueous calcium chloride solutions |
| | aqueous zinc chloride solutions | road salt solution in contact with zinc-plated components | aqueous zinc chloride solutions |
| Solvents | | concentrated sulfuric acid | |
| | | formic acid 90 % | |
| | | hexafluoroisopropanol (HFIP) | |

Table 7: Overview of the media resistance of Ultramid® (discoloration of the test specimens is not taken into consideration during the evaluation of the resistance)



| Examples | Ultramid® S | Examples | Ultramid® Advanced (PPA) | Examples |
|--|----------------------|--|--------------------------|--|
| concentrated hydrochloric acid, battery acid, sulfuric acid, nitric acid | mineral acids | concentrated hydrochloric acid, battery acid, sulfuric acid, nitric acid | mineral acids | concentrated hydrochloric acid, battery acid, sulfuric acid, nitric acid |
| halogens, oleum, hydrogen peroxide, ozone, hypochlorite | oxidants | halogens, oleum, hydrogen peroxide, ozone, hypochlorite | oxidants | halogens, oleum, hydrogen peroxide, ozone, hypochlorite |
| road salt | | | | |
| road salt solution in contact with zinc-plated components | | | | |
| concentrated sulfuric acid | | concentrated sulfuric acid | | concentrated sulfuric acid |
| formic acid 90 % | | formic acid 90 % | | formic acid 90 % |
| hexafluoroisopropanol (HFIP) | | hexafluoroisopropanol (HFIP) | | hexafluoroisopropanol (HFIP) |



Splitter floor heating



Oil filter module

Behavior on exposure to weather

Ultramid® is suitable for outdoor applications. Different grades come into consideration depending on requirements.

The unreinforced, stabilized grades with K as identifier are highly resistant to weathering even when unpigmented. Suitable pigmentation increases outdoor performance further, best results are achieved with carbon black.

The reinforced grades also exhibit good weather resistance; stabilized grades, e.g. Ultramid® B3WG6 BK564, will retain their weather resistance for well over ten years.

However, owing to the glass fibers, the surface is attacked to a greater extent compared to unreinforced Ultramid®, which means that the quality of the surface and its color can change after a short period of outside weathering. As a result, such materials can slowly turn grey. In the case of colored grades, the level of resistance is essentially dependent on the pigments that are used. The natural and pigmented products from the E2 portfolio are suitable for applications requiring a particularly high degree of color and UV stability. Grades with special UV stabilization and products with a high carbon black content, e.g. Ultramid® B3GM35 SWQ642 23220, have proved effective in exterior applications, e.g. housings for automobile mirrors that must retain their surface quality even over many years of use.

After several years of weathering, the surface layer of standard grades is likely to show signs of wear down to several micrometers. This causes a slight discoloration as described before. In the case of dark shades the material turns greyish. However, experience shows that this does not have any obvious adverse effect on the mechanical properties. This is illustrated by results from ten-year outdoor weathering tests (Fig. 32). Only a slight reduction of mechanical values is observed once the conditioned state has been reached.

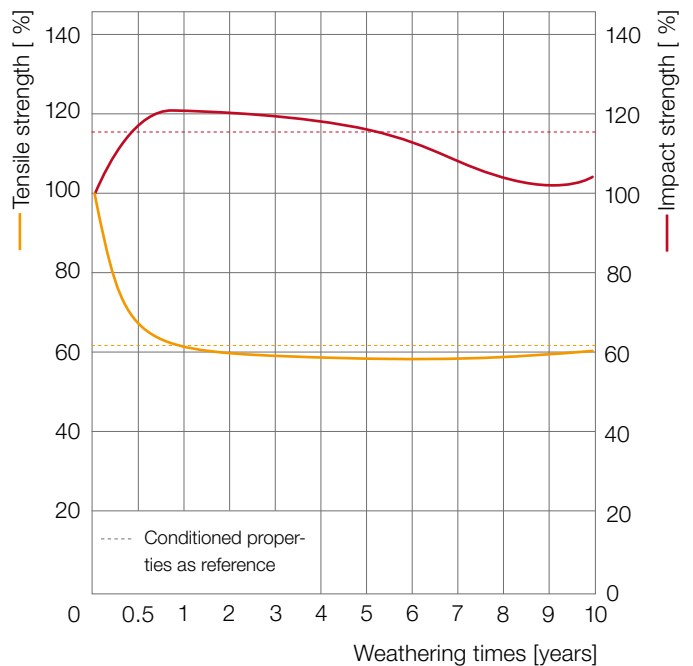

Fig. 32: Change in the mechanical values of Ultramid® B3WG6 BK564 after outdoor weathering



Fixing clip for photovoltaic modules

The processing of Ultramid®

Processing characteristics

Ultramid® can be processed by all processing techniques known for thermoplastics primarily injection molding and extrusion. Complex moldings are economically manufactured in large numbers by injection molding. The extrusion method is used to produce films, semi-finished products, pipes, profiles, sheets and monofilaments. Semi-finished products are usually further processed by machining to finished parts.

Some general aspects regarding injection molding of Ultramid® is shown in the following chapters. Detailed information can be found at www.plastics.basf.com or via Ultraplaste Infopoint (ultraplaste.infopoint@basf.com). The injection molding conditions of each individual product are given in the respective processing data sheet.

Melting and setting behavior

The softening behavior of Ultramid® on heating is shown by the shear modulus measured in accordance with ISO 6721-2 as a function of temperature (Figs. 14 and 15). Pronounced softening only occurs just below the melting point. Glass fibers increase the softening point. A measure commonly used to determine the softening temperature is the heat deflection temperature HDT in accordance with ISO 75.

The melt solidifies during cooling within a narrow temperature range around 20 °C to 40 °C below melting point depending on the cooling rate and the Ultramid® grade. At the same time there is a contraction in volume of roughly 3% to 15%. The total volume contraction can be deduced from the curves of the pVT diagram in Fig. 33. The crystallization temperature and pvt behavior is also included in commonly available programs for the simulation of injection-molding process.

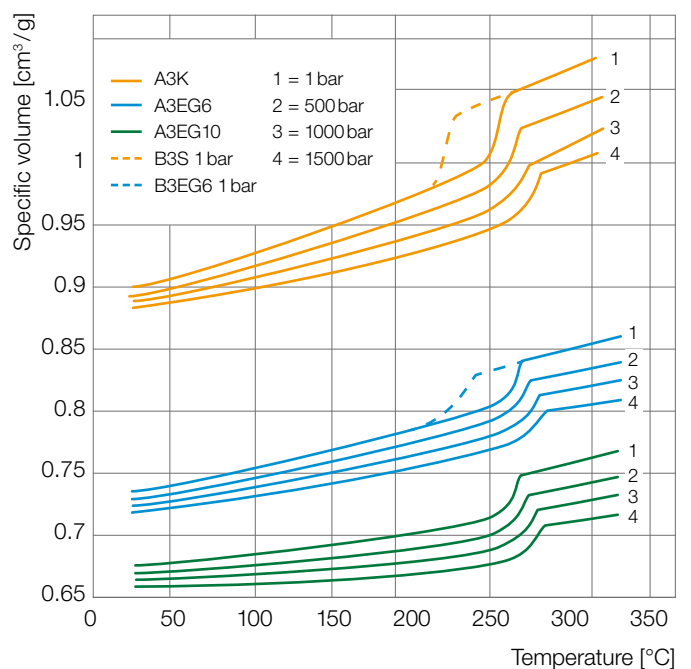

Fig. 33: pVT diagram of Ultramid® A and B grades

Thermal properties

The relatively high specific enthalpy of Ultramid® requires efficient heating elements. As the freezing and cooling times increase with the square of the wall thickness, varying wall thicknesses should be avoided to ensure cost-efficient production.

Melt viscosity

The flow behavior of Ultramid® melts can be evaluated on the basis of viscosity diagrams, obtained from measurements using a capillary rheometer or on the basis of injection-molding tests.

In the range of the processing temperatures the Ultramid® grades have a melt viscosity of 10 to 1,000 Pa·s (Figs. 34 and 35), highly depending on temperature and shear rate. The higher the relative molar mass or the relative solution viscosity (given by the first digit in the nomenclature), the higher is the melt viscosity and the lower the flowability (Fig. 34). In the case of Ultramid® grades with mineral filler or glass-fiber reinforcement, the viscosity increases depending on the amount of reinforcement. In addition to standard materials, the Ultramid® portfolio includes products with optimized flowability (Fig. 35).

The melt viscosity can change due to different reasons. For example if the melt is too moist, too hot or exposed to high mechanical shear forces the viscosity can decrease. Oxidation can lead to a lower viscosity. All these factors have an effect on mechanical properties and the heating aging resistance of the finished parts or the semi-finished products.

Thermostability of the melt

Appropriate processing assumed the thermostability of Ultramid® melts is outstanding. With normal processing conditions, the material is not affected. Degradation in the polymer chains only occurs when the residence time is too long or the temperature is too high. The recommended melt temperatures for processing can be found in Tables 8 and 9 and the Ultramid® range overview or the processing data sheet of the relevant product.

If the melt does not come into contact with oxygen, no significant color changes occur. Exposed to air, for example, when open injection nozzles are used or in case of interruptions in production, the surface can already become discolored after a brief time.

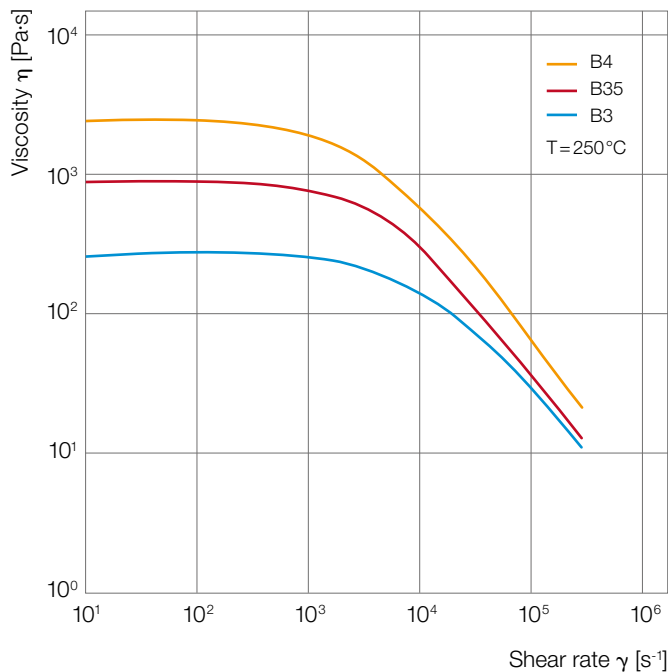

Fig. 34: Apparent viscosity of Ultramid® B (unreinforced) as a function of shear rate

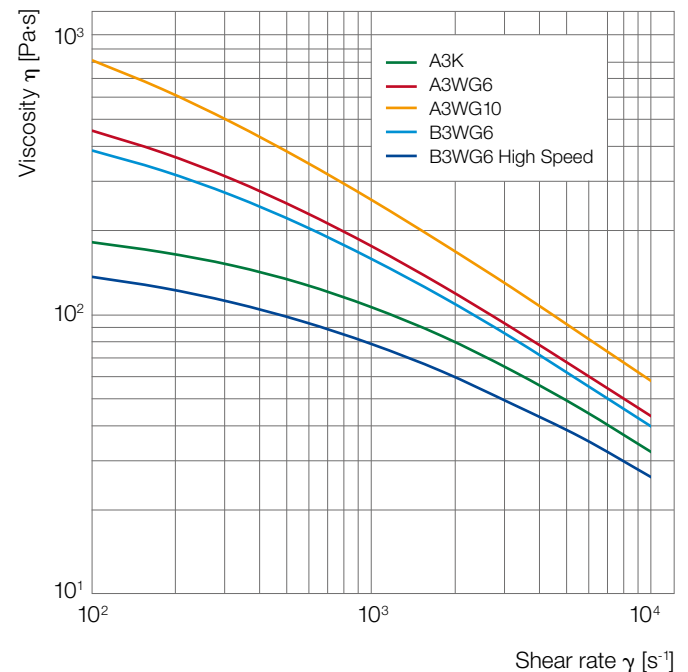

Fig. 35: Apparent viscosity of Ultramid® A and B with different glass fiber contents, T = 280°C

General notes on processing

Preliminary treatment, drying

Ultramid® must be processed dry. If the moisture content is too high, processing problems and quality losses can occur. Feed and dosing behavior and thus the process consistency as well as the quality of the molded part surface can be negatively influenced. In the case of flame-retardant grades, mold deposit can be formed. The loss of mechanical properties, e.g. by splitting molecular chains, is also possible.

In order to prevent the formation of condensation, containers which are stored in non-heated rooms should only be opened once they have reached the temperature in the processing room. Ultramid® should be pre-dried according to our recommendations, regardless of the storage conditions.

The drying time – usually from 4 to 8 hours – is dependent on the moisture content and product. Among the different dryer systems, dehumidifying dryers are the most efficient and reliable. The optimum drying temperatures for Ultramid® are approx. 80 °C to 120 °C. As a general rule, the specifications of the equipment manufacturer should be followed. The use of vented screws for releasing the moisture as part of the injection-molding process is not advisable.

Light granules and thermally sensitive colors should be dried under careful conditions at granule temperatures not exceeding 80 °C in order to avoid a color change. The mechanical properties of the finished parts are not influenced by drying temperatures of up to 120 °C.

Detailed recommendation for drying each product can be found in the processing data sheets.

Self-coloring

Self-coloring of Ultramid® by the injection molder is generally possible. The colorants of Ultramid® T KR and Ultramid® Advanced, which are generally processed at temperatures above 310 °C, must be thermally stable.

The properties of self colored parts, especially homogeneity, impact strength, fire and shrinkage characteristics, have to be checked carefully because they can be dramatically influenced by the additives and the processing conditions.

Ultramid® grades that are UL94-rated must adhere to the stipulations of UL 746D if the UL rating is to be retained. Only PA-based color batches that are HB-rated or higher may be used for the self-coloring of UL 94 HB-rated Ultramid® grades. Ultramid® grades that are UL 94 V-2, V-1 or V-0 rated may only be colored with UL-approved color batches (special approval required).

Self-colored molded parts used in the food contact sector must comply with special requirements (see “Safety notes – food legislation”).

Reprocessing and recycling

Regrind material from sprues and rejected parts from the processing of Ultramid® can be reused to a limited extent, provided they are not contaminated. It should be noted that the regrind is particularly hygroscopic, so it should generally be dried carefully before being processed. Repeated processing can cause damage.

In specific cases, it may be helpful to check the solution viscosity or the melt viscosity. Whether the addition of recycled material is permitted in the particular application must be clarified in advance. Restrictions on the amount of recycled material in flame-retardant products (e.g. under UL specifications) must also be considered.

As Ultramid® is not homogeneously mixable with most other thermoplastics, including PS, ABS, and PP, only pure mixtures of new and recycled product may be processed. Even small amounts of such “impurities” usually have a negative effect which becomes apparent, for example, as delaminated structures – especially close to the gate – or in a reduced impact strength.

Machine and mold technique for injection molding

Ultramid® can be processed on all commercial injection molding machines.

Plasticizing unit

The single-flighted three-section screws usual for other engineering thermoplastics are also suitable for the injection molding of Ultramid®. In modern machines, the effective screw length is $20-23 \cdot D$ and the pitch $1.0 \cdot D$. The geometry of the three-section screw, which has long proved effective, is shown in Fig. 36.

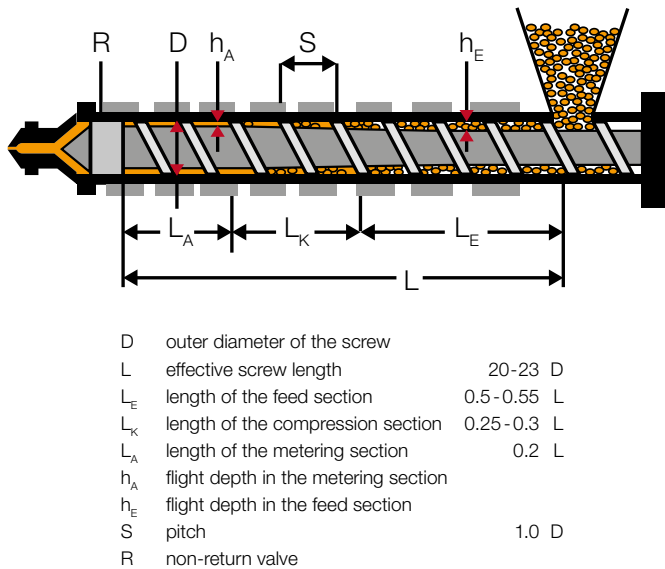

Fig. 36: Screw geometry – terms and dimensions for three-section screws for injection-molding machines

Recommended flight depths are shown in Fig. 37. These flight depths apply to standard and more shallow-flighted screws and afford a compression ratio of about 1 to 2. Shallow-flighted screws convey less material than deep-flighted ones. The residence time of the melt in the cylinder is therefore shorter. This means that more gentle plastification of the granules and greater homogeneity of the melt can be an advantage for the quality of injection-molded parts.

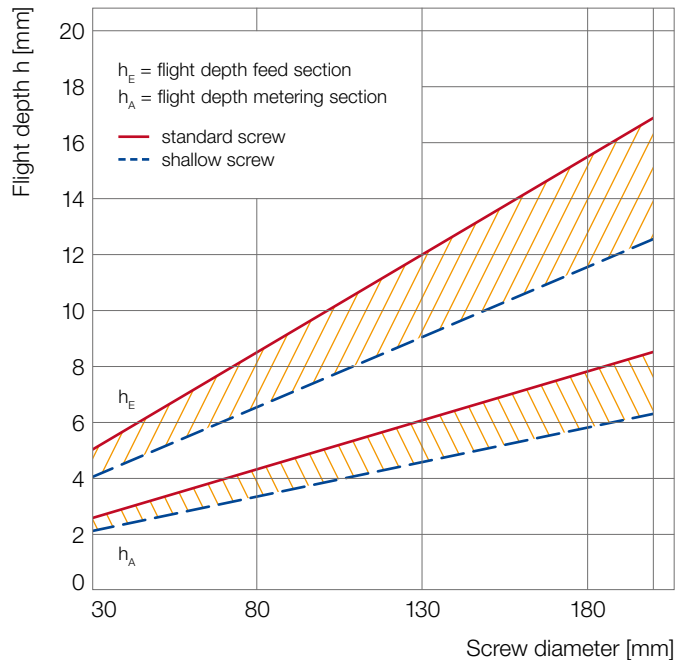

Fig. 37: Flight depths for three-section screws in injection-molding machines

In order to ensure that moldings can be manufactured in a reproducible way, it is important to have a non-return valve, which is designed to enable a good flow and a tight closing. This allows a constant melt cushion and a sufficient holding pressure time to be achieved. The clearance between the cylinder and the valve ring should be not more than 0.02 mm.

Ultramid® can be processed both with needle valve nozzles and open nozzles. Open nozzles are advantageous for material and color changes and lead to lower shear stresses. If a vertical plasticizing unit is used and/or the melt viscosity is lower it is often impossible to stop the melt from leaking out of an open nozzle. In this case needle valve nozzles have to be preferred.

The machine nozzle should be easy to heat and has an additional heater band for this purpose if necessary. So it is possible to prevent undesired freezing of the melt. For the processing of mainly glass-fiber reinforced materials the use of hard-wearing plasticizing units is recommended. The processing of flame-retardant grades may require the use of corrosion-resistant steels.

Injection mold

The design rules for injection molds and gating systems which are specified in the relevant literature also apply to moldings made of Ultramid®.

Filling simulations at an early stage can make an important contribution to the design, especially if the molded parts have complex geometries.

Molded parts made of Ultramid® are easy to demold. The draft on injection molds for Ultramid® is generally 1 to 2 degrees. With drafts of a lower angle, the demolding forces increase greatly, which means that more attention has to be paid to the ejector system.

In principle, Ultramid® is suitable for all usual kind of gates. If hot runner nozzles are used, it should be possible to regulate them individually. Heated components must have a homogeneous temperature level.



Front end carrier

Gates must be sufficiently large in size. Gate cross sections that are too small can cause a wide range of problems. These include material damage resulting from excessively high shear stress or insufficiently filled molded parts as a result of pressure losses. Premature freezing of the melt before the end of the holding pressure time can cause voids and sink marks.

In the case of fiber-reinforced grades, increased wear occurs in the gate area at relatively high output rates; this can be countered by selecting suitable types of steel and using changeable mold inserts. Corrosion-resistant, high-alloy steels (for example DIN 1.2083, X42Cr13) have proven suitable for processing flame-retardant products.

When the melt is injected, the air in the mold cavity must be able to escape easily – especially at the end of the flow path or at places where flow fronts meet – so that burned marks from compressed air are not produced (diesel effect). This applies particularly to the processing of flame-retardant grades. Figure 38 illustrates how mold vents can be realized.

The quality of moldings is highly dependent on the temperature conditions in the mold. A precise and effective mold temperature control is possible only with a well-designed system of temperature control channels in the mold, together with temperature control devices of appropriate power. The mold temperatures required for Ultramid® can be achieved with temperature control devices using water, with system pressure being superimposed in a controlled way if necessary.

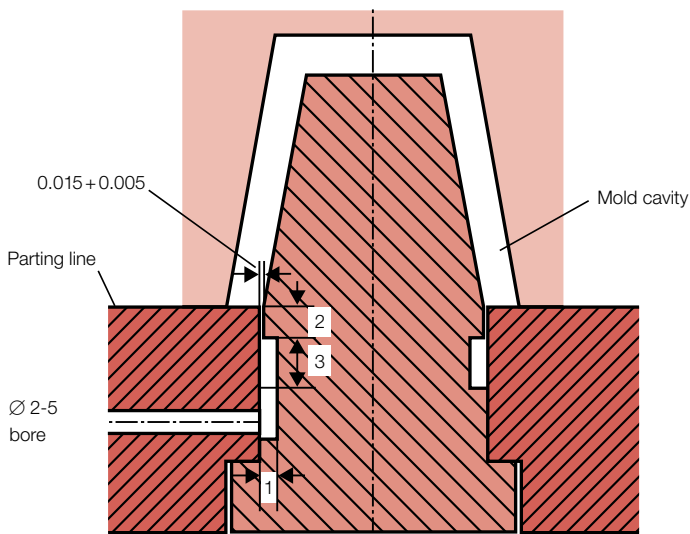

Fig. 38: Design diagram for mold venting (all size in mm)



Thermal dowel

Injection molding

The injection molding machine is started up in the usual way for thermoplastics: the cylinder and nozzle heating are adjusted to ensure that the required melt temperature is reached (guide values in Table 9). As a precaution, the melt exposed to thermal stresses during the heating-up phase is pumped off. After this, the optimum processing conditions have to be determined in trials.

If flame-retardant grades are processed, it is recommended that the melt should not be pumped off but rather injected into the mold. If pumping off cannot be avoided, an extraction device (hood) should be available and the melt cooled in the water bath. Further information can be found in the chapter "General information" under "Safety notes – safety precautions during processing".

The residence time of the plastic in the plasticizing cylinder is a major factor determining the quality of the molding. Residence times that are too short can result in thermal inhomogeneities in the melt whereas, if they are too long (> 10min), they often result in heat damage.

Processing temperatures

The different Ultramid® product groups are processed over a wide melt and mold temperature range. An overview of the guide values for each of the product groups can be found in Fig. 39.

Detailed information on the melt and mold temperature range and the optimum processing parameters is provided in the processing data sheet for the particular product. The optimum melt temperature within the given range is dependent on the flow path and wall thickness of the molded part as well as the plasticizing unit and used injection-molding process itself.

Low melt temperatures can be used for short flow paths and/or larger flow cross sections. Higher melt temperatures are to be avoided because of possible thermal damage or even decomposition of the melt. Slight increases are permitted only for short production or dwell times of the melt in the cylinder. Damage can appear as impaired optical and mechanical properties.

When dwell times are long, careful melting is achieved by adjusting the temperatures of the cylinder heater bands so that they increase gradually between the hopper (setting between 50 and 80 °C) and the nozzle. An increase from 20 °C below the desired melt temperature to the melt temperature at the nozzle has proved effective (e. g. 260 °C rising to 280 °C for unreinforced Ultramid® B).

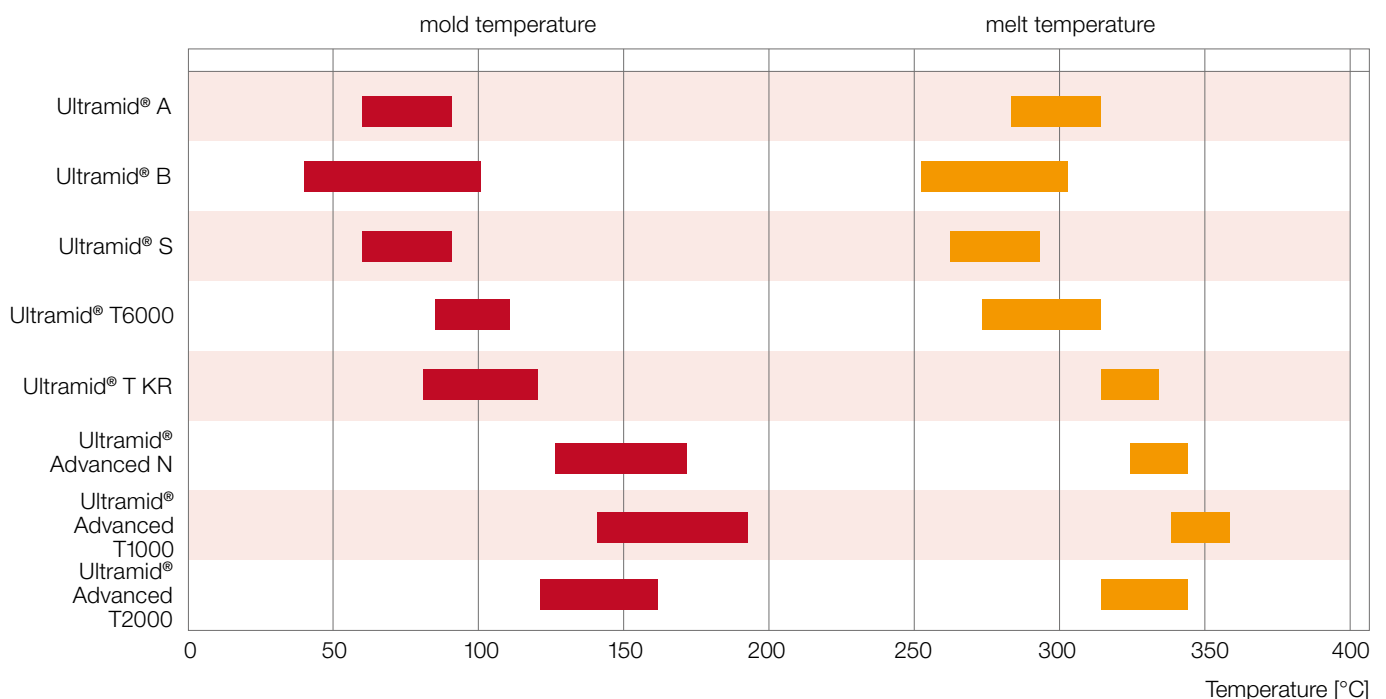

Fig. 39: Melt and mold temperature range of different Ultramid® product groups

When dwell times are short, horizontal cylinder temperature control makes sense.

When using an open nozzle, the melt can be prevented from leaking by reducing the nozzle temperature. Measurement of the actual melt temperature in front of the screw, either with an inserting thermometer or an integrated temperature sensor, is recommended.

Unreinforced Ultramid® is processed usually at mold temperatures of 40°C to 80°C. Reinforced Ultramid® grades require higher temperatures. In order to achieve good surface qualities and moldings meeting high requirements for hardness and strength, the surface temperatures of the mold cavities should be 80°C to 90°C, and in special cases 120°C to 140°C. An increase in the mold temperature may require a longer cooling time, which extends the cycle time.

Screw speed

If possible, the screw speed should be adjusted in order that the available time for plasticising within the molding cycle is fully utilised. For instance, a speed of 75 to 115 min⁻¹ (corresponding to a peripheral screw speed of 0.2 to 0.3 m/s) is often adequate for a 50 mm diameter screw. Too high screw speeds lead to temperature rises due to frictional heating. During the processing of glassfiber reinforced products a high screw speed may result in a shortening of the glass fibers.

Injection rate

The rate at which the mold is filled affects the quality of the moldings. Fast injection leads to equal solidification and a good quality of the surface, especially in the case of parts made of glass-fiber reinforced Ultramid®. However, a reduced injection speed can be used for very thick-walled molded parts to avoid an open jet.

Transmission cross beam



Exterior mirror base

Holding pressure

In order to prevent sink marks and voids, the holding pressure and the holding pressure time must be chosen to be sufficiently high so that the contraction in volume which occurs when the melt cools is largely compensated for. If the holding pressure is too high, it can cause internal stresses in the component or lead to demolding problems. In some cases, a stepwise reduced holding pressure can be an advantage.

Flow behavior

The flow behavior of plastic melts can be estimated through a spiral test using spiral molds on commercial injection-molding machines. The flow path covered by the melt – the length of the spiral – is a measure of the flowability of the processed material.

The flow path distances of flow spirals of different thicknesses are shown in Table 8 for some Ultramid® grades. The relationship between the flow spiral length and the wall thickness produces the flow path-wall thickness ratio. This ratio allows a rough comparison of the flow properties of the different thermoplastics. However, it has to be considered that the flow properties depend on the mold design and the moisture content of the granulate as well as the processing conditions (particularly the temperatures). The Ultramid® range contains some grades with optimized flowability, which can cover longer flow paths at the same wall thickness e.g. Ultramid® High Speed.

| Ultramid® | Melt temperature [°C] | Mold temperature [°C] | Spiral length | | |
|-------------------|--------------------------|--------------------------|---------------|--------|--------|
| | | | 1.0 mm | 1.5 mm | 2.0 mm |
| A3K | 290 | 60 | 200 | 385 | 640 |
| A3X2G5 | 300 | 80 | 145 | 300 | 430 |
| A3EG7 | 290 | 80 | 130 | 245 | 400 |
| A3X2G7 | 290 | 80 | 105 | 180 | 295 |
| A3U42G6 | 290 | 80 | 110 | 210 | 290 |
| B3S | 260 | 80 | 170 | 305 | 520 |
| B3U30G6 | 270 | 80 | 230 | 380 | 645 |
| B3WG3 | 280 | 80 | 170 | 290 | 490 |
| B3WG6 | 280 | 80 | 140 | 245 | 405 |
| B3WG6 High Speed | 280 | 80 | 200 | 375 | 605 |
| B3WG10 | 300 | 100 | 150 | 265 | 410 |
| B3WGM24 HP | 280 | 80 | 195 | 385 | 575 |
| B3WG12 High Speed | 290 | 100 | 105 | 250 | 360 |
| S3WG6 Balance | 290 | 80 | 150 | 280 | 335 |
| T KR 4350 | 330 | 90 | 170 | 295 | 400 |
| T KR 4357G6 | 330 | 100 | 130 | 210 | 330 |
| T KR 4365G5 | 330 | 100 | 100 | 165 | 265 |

Table 8: Flow behavior of different Ultramid® grades during injection molding

Shrinkage and aftershrinkage

ISO 294-4 defines the terms and test methods for shrinkage in processing. According to this, shrinkage is defined as the difference in the dimensions of the mold and those of the injection-molded part at room temperature. It results from the volumetric contraction of the melt in the injection mold due to cooling, change in the state of aggregation and crystallization. The shrinkage is measured according to ISO 294-4 after a storage of the parts for 16 to 24 hours in standard climate (23 °C/50 % r.h.).

Shrinkage is also affected by the geometry (free or impeded shrinkage) and the wall thickness of the molded part (Fig. 40). In addition, the position and size of the gate and the processing parameters (melt and mold temperature, holding pressure and holding pressure time together with the storage time and storage temperature) play an important role. The interaction of these various factors makes it difficult to predict the shrinkage of a part exactly.

| Ultramid® | Melt temperature [°C] | Mold temperature [°C] | Molding shrinkage [%] | | |
|---------------------|--------------------------|--------------------------|-----------------------|---------------------|------------|
| | | | Testbox ¹⁾ | Sheet ²⁾ | |
| | | | | crosswise | lengthwise |
| A3K, A3W | 290 | 60 | 0.90 | 1.50 | 1.80 |
| A3HG5, A3EG5, A3WG5 | 290 | 80 | 0.55 | 0.50 | 1.05 |
| A3X2G5 | 290 | 80 | 0.50 | 0.40 | 1.15 |
| A3EG6, A3WG6 | 290 | 80 | 0.55 | 0.45 | 1.00 |
| A3X2G7 | 290 | 80 | 0.45 | 0.35 | 1.15 |
| A3EG10, A3WG10 | 300 | 80 | 0.45 | 0.35 | 0.85 |
| A3U42G6 | 290 | 80 | 0.35 | 0.30 | 0.90 |
| B3S | 260 | 80 | 0.40 | 0.90 | 0.90 |
| B3ZG3 | 280 | 80 | 0.50 | 0.60 | 0.70 |
| B3ZG6 | 280 | 80 | 0.40 | 0.30 | 0.70 |
| B3EG6 | 280 | 80 | 0.30 | 0.25 | 0.70 |
| B3WG6 | 280 | 80 | 0.30 | 0.30 | 0.75 |
| B3WG7 | 280 | 80 | 0.30 | 0.25 | 0.75 |
| B3WG10 | 300 | 80 | 0.30 | 0.20 | 0.70 |
| B3WGM24 HP | 280 | 80 | 0.20 | 0.40 | 0.60 |
| B3U30G6 | 270 | 80 | 0.50 | 0.40 | 0.90 |
| B3U42G6 | 280 | 80 | 0.30 | 0.20 | 0.70 |
| B3K6 | 280 | 80 | 0.70 | 1.15 | 1.10 |
| B3GK24 | 280 | 80 | 0.45 | 0.60 | 0.80 |
| B3M6 | 280 | 80 | 0.75 | 1.30 | 1.10 |
| B3WGM35 R03 | 280 | 80 | 0.35 | 0.35 | 0.80 |
| C3U | 270 | 60 | 0.80 | 1.25 | 1.30 |
| S3WG6 Balance | 270 | 80 | 0.40 | 0.40 | 0.90 |
| T KR 4350 | 315 | 90 | 0.60 | 0.90 | 1.10 |
| T KR 4357 G6 | 320 | 100 | 0.35 | 0.40 | 1.00 |

Table 9: Shrinkage behavior of different Ultramid® grades

¹⁾ Impeded shrinkage, see Fig. 42, line A, wall thickness 1.5 mm, holding pressure 800 bar

²⁾ Free shrinkage according to ISO 294-4, sheet 60 x 60 x 2 mm, cavity pressure 500 bar

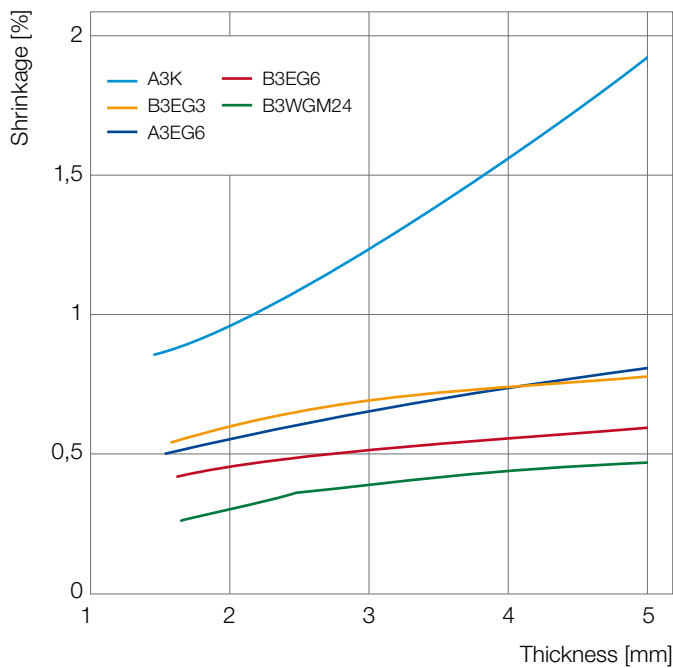

Fig. 40: Impeded shrinkage of Ultramid® as a function of wall thickness, test box, line A, holding pressure: 600 bar

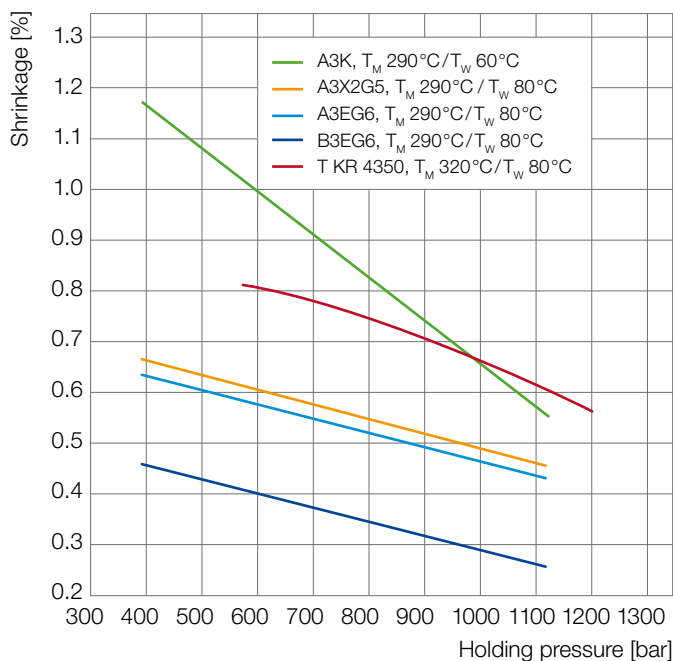

Fig. 41: Shrinkage of Ultramid® A, B and T as a function of holding pressure, test box, line A, thickness: 1.5 mm

The shrinkage values measured on plates 60mmx60mmx2mm according to ISO 294 can be used to compare the shrinkage of different materials. The plaques injected with a film gate have the minimum and maximum shrinkage parallel and perpendicular to the flow direction because of the high orientation of the molecules and, particularly, the fibers. The value measured on the test box (Fig. 42) can be used as a guide for the average shrinkage in a real part since, here, the flow front tends to run radially from the injection point. Table 9 gives an overview of the shrinkage values of various Ultramid® grades.

Unreinforced polyamides generally shrink more than reinforced grades. Some processing conditions have a significant effect on dimensional stability, particularly in unreinforced products. These include the mold temperature, holding pressure and time. Nevertheless, the possible holding pressure range of a real part is usually limited, as a too low holding pressure can lead to sink marks and a too high holding pressure to demolding problems. However, the melt temperature generally has relatively little effect. The factors that may affect reinforced Ultramid® are limited by the processing parameters. Figures 41, 43 and 44 show shrinkage values of reinforced and unreinforced Ultramid® as a function of holding pressure, melt and mold temperature.

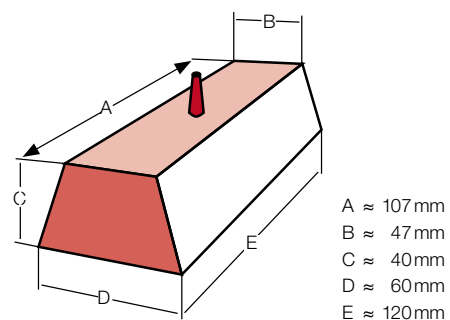

Fig. 42: Test box

Post-shrinkage means that the dimensions of the moldings may change slightly over time because internal stresses and orientations are dissipating and post-crystallization can take place depending on time and temperature. Whereas the post-crystallization is comparatively low at room temperature, at higher temperatures it can result in a possibly significant dimensional change. The process of post-shrinkage can be accelerated by annealing. High mold temperatures reduce the level of post-shrinkage and can therefore replace an additional annealing process (Fig. 44).

Moldings of glass-fiber reinforced products show a significant difference in the shrinkage perpendicular and parallel to the flow direction (shrinkage anisotropy). This is the result of the typical orientation of the glass fibers longitudinally to the flow direction (Fig. 45).

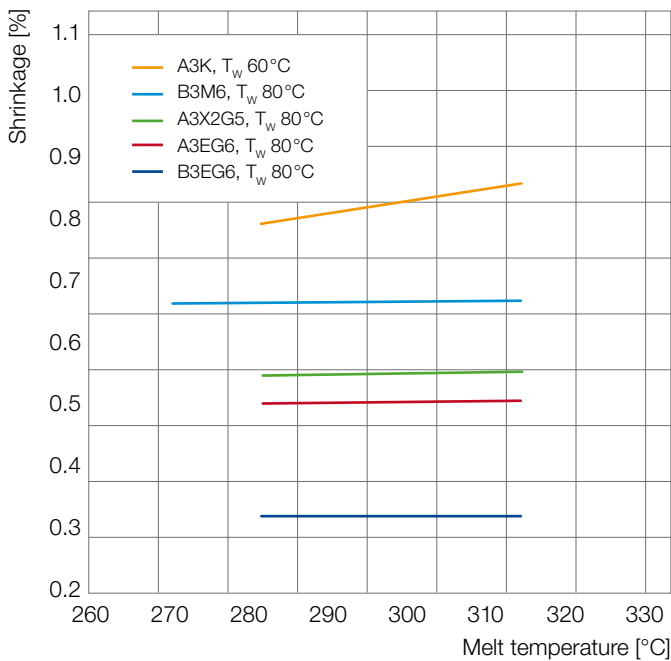

Fig. 43: Shrinkage of Ultramid® A and B as a function of melt temperature, test box, thickness: 1.5 mm

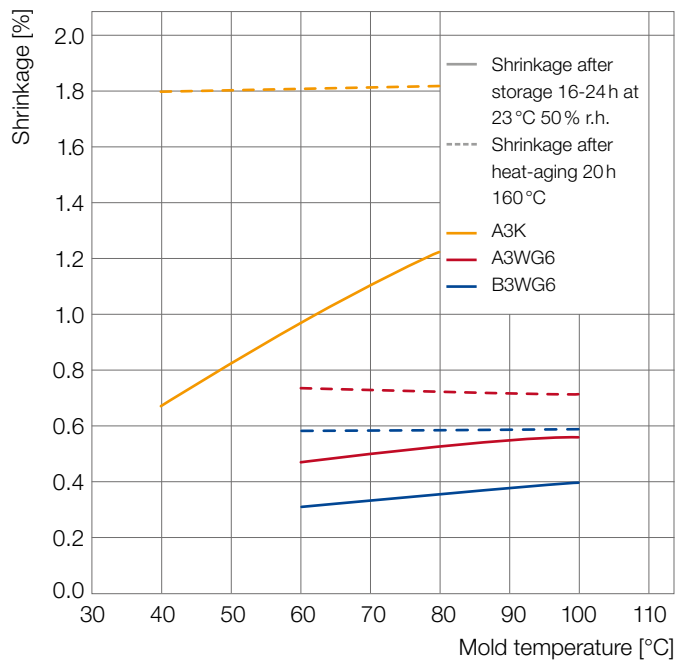

Fig. 44: Shrinkage after storage in standard climate (23°C, 50% r.h.) and after heat-aging 20h at 160°C of Ultramid® A and B as a function of the mold temperature, test box, thickness: 1.5 mm

Warpage

Warpage in a molding is mainly caused by different shrinkages in flow direction and perpendicular. That is why parts made of glass-fiber reinforced materials tend more to warp than those made of unreinforced products. In addition, it depends on the shape of the moldings, the distribution of wall thicknesses and on the processing conditions.

In the case of unreinforced grades, different temperature control of individual parts of the mold (core and cavity) can allow the production of warp-free or low-warpage molded parts. Thus, for example the warpage of housing parts to the inner side can be counteracted by low core and high cavity temperatures.

Mineral and glass bead-filled grades are characterized by largely isotropic shrinkage. They are therefore the preferred materials for molded parts with low warpage.

Special processes

Chemical and physical foaming

The addition of chemical or physical blowing agents causes the melt to expand during the filling of the mold. Sink marks can be avoided even with large wall thicknesses. If necessary, it also allows the weight of the component to be reduced. In addition, the fill pressure is considerably reduced so that a machine with a lower clamping force can be used. Foamed components have lower warpage than compact injection molded components. However, it should be considered that the mechanical and the surface properties can be influenced in a negative way depending on the level of expansion. With selected Ultramid® grades from the range, good surfaces can be achieved, even with foam injection molding.

An experienced team of experts is available to answer questions about processing, processing methods and special processing methods. A well-equipped processing technology center can be used for research, development and project studies. The back injection molding of thermoplastic composites, multi-component injection molding, GID/WIT technology and processing of high-temperature thermoplastics are some of the special processes that are possible in our technical lab.

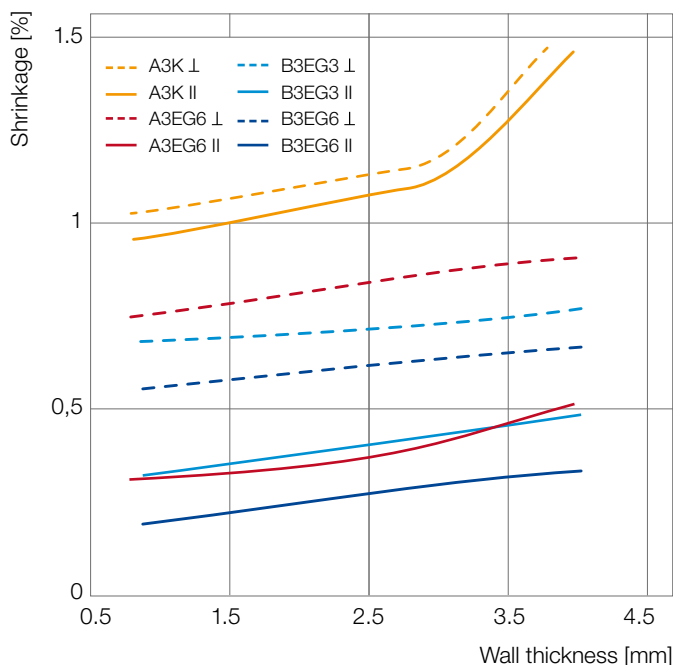

Fig. 45: Impeded shrinkage of different Ultramid® grades as a function of wall thickness, sheet 110 x 110 mm with a film gate and injection molded corners to impede deformation, holding pressure = 500 bar; perpendicular (⊥) and parallel (||) to the flow direction

Injection molding with fluid injection technology (FIT)

Fluid injection technology offers opportunities that are interesting from a technological and economic point of view for producing complex, (partially) thick-walled molded parts with hollows and functions that can be integrated. Typical FIT components made of Ultramid® are media lines in automobiles, handles, brackets and chairs.

After the melt has been injected, a fluid is used to eliminate any residual molten material. Depending on the application, the fluid used can be gas or water. With projectile injection technology, a fluid-driven projectile is used.

The fluid pressure applied internally can reduce the warpage of the component. Shorter cycle times can also be achieved because more heat is dissipated with water and the accumulation of melt is avoided. Other advantages are greater freedom of design and the opportunity to create components with high specific rigidity.

At present, the products used are primarily reinforced Ultramid® grades. Some Ultramid® grades are optimized for FIT; for example the hydrolysis-resistant Ultramid® A3HG6 WIT is particularly suitable for cooling water pipes, while other grades, e.g. Ultramid® B3WG6 GIT, allow particularly good surface qualities.

Overmolding of inserts

Well known applications in which metal inserts are overmolded with Ultramid® include connecting elements such as shells or inserts and conductor paths or similar elements in control housings. These molded parts require a particularly good joint between the metal and plastic if they need to be resistant to media or are exposed to varying temperatures.

The metal inserts should be pre-heated to 100°C to 150°C, but at least to mold temperature, before overmolding to prevent excessive internal stresses in the molded part. The metal parts must be grease-free and, where necessary, should have knurls, surrounding notches or similar elements for more fixing. Other metal pre-treatments such as structuring of the contact area, plasma nitriding or special coatings can also improve adhesion.

Expanded Ultramid® is also ideal for overmolding with PA injection-molding materials, combining the advantages of foam and injection-molding. By melting the surface with the hot melt, an almost inseparable, homogeneous PA composite body is created. This combination opens up new design possibilities: depressions in the EPA core become ribs, and openings turn into flow channels – allowing for the realization of complex, large-volume, yet lightweight monomaterial components that offer advantages in terms of recycling, among others.

Multi-component technology

The combination of several materials in one molding has become firmly established in injection molding technology. Various Ultramid® grades are used here, depending on what component properties are required. The components must be matched to one another in respect of their processing and material properties. A lot of experience exists in relation to the way that different materials adhere to Ultramid®.



Coolant water pipe

Processing on steam molding machines

The molding process in steam pressure technology – also known as Steam Chest Molding – utilizes saturated water vapor to process pre-foamed particles in closed mold forms. This results in complex, lightweight, and simultaneously highly load-bearing components. Ultramid® Expand has been specifically developed for this technology and can be used on common machines (with typical steam pressures of 3-4 bar) for the production of particle foam parts. The steam pressure molding process, typically used for processing particle foams like Ultramid® Expand, occurs in four stages:

- Filling the cavity: The mold is filled with the pre-foamed particle (Ultramid® Expand).
- Steam application: Cross steam and autoclave steam are introduced to soften the particles and weld them together.
- Cooling: The molded component is cooled with water to ensure shape stability.
- Demolding: The finished particle foam parts are removed from the mold using an ejector. After removal, the component should be dried. During the design process, shrinkage should be taken into account, as the material has an equilibrium moisture content of 2-3%.



Foamed, ribbed inserts made from Ultramid® Expand, directly overmolded with reinforced and unreinforced polyamide

Joining methods

Parts made of Ultramid® can be joined by a variety of different methods. These include the following in particular:

- Snapping together
- Screwing together with self-tapping metal screws
- Screwing together with threaded inserts
- Riveting
- Adhesive bonding
- Welding

Snap fittings can easily be integrated into Ultramid® plastic parts. Good flexibility over a large temperature range is particularly advantageous for this joining method.

Direct screw fixings and screw fixings with threaded inserts allow strong bonds to be formed between two Ultramid® parts and between Ultramid® parts and parts made of other materials.

Riveted joints are generally produced with integrated rivets. These can be softened by ultrasound, a hot riveting die, hot gas or a laser. A form closure is created by the subsequent molding of the rivet head.

All common adhesive systems are suitable for bonding Ultramid®. The complexity of the bonding process requires particular care to be taken when choosing the adhesive and pre-treating the parts.

Virtually all common methods can be used to weld Ultramid®:

- Friction welding (vibration and spin welding)
- Ultrasonic welding
- Laser beam welding
- Infrared welding
- Hot gas welding
- Heat impulse welding
- High frequency welding

These welding methods have their own specific advantages and disadvantages and require certain material properties and joining geometries. As the optimum weld geometry depends on the welding method used, the method should be chosen before the final design is drawn up. Ultramid® absorbs moisture, which can have a major impact on the quality of the compound. Therefore, the moisture content must be taken into account in the production and use of Ultramid® joints.

With Ultrajoin® and Ultratest® BASF offers its customers extensive support: from the choice of the most suitable bonding technique to the design of the joint to the optimization of the joining process (Ultratest® and Ultrajoin® are registered trademarks of BASF SE).

Machining

Semi-finished products made from Ultramid® can be processed with all commonly known tooling machines. As a general rule of guidance, one might use an adjusted feed rate and a high cutting speed. Additionally, tools should be checked for sufficient sharpness.

Marking and coating

Laser marking

Marking Ultramid® using lasers affords a series of advantages over conventional methods, particularly when there are tough requirements for permanence, flexibility and speed.

The following information is intended only to provide initial guidance. The Ultra-Infopoint will be happy to give more detailed advice on the choice of Ultramid® colors that are best suited to laser marking.

Nd:YAG lasers (wavelength 1064 nm)

Uncolored standard Ultramid® grades are practically impossible to mark with Nd-YAG lasers due to very low absorption of energy. This also applies to glass-fiber reinforced and mineral-filled grades. Better markability for Ultramid® grades can be achieved by using special additives. High-contrast lettering is obtained with certain black pigmentations.

Uncolored Ultramid® A3X grades can be marked with good contrast but not in customary black colors.

The Ultramid® LS range comprising unreinforced, reinforced and flameproofed grades was specially developed for marking using the Nd-YAG laser. The Ultra-Infopoint will be happy to send you an overview on request.

Nd:YAG lasers (wavelength 532 nm)

A frequency-doubled Nd-YAG laser can generally produce higher definition and higher contrast images on uncolored and brightly colored Ultramid® grades than a Nd-YAG laser with 1064 nm. There is no advantage in the case of black colors.

Excimer lasers (wavelength 175-483 nm)

Excimer lasers produce a higher definition and a better surface finish on Ultramid® than do Nd-YAG devices. Good results are achieved especially for bright colors.

CO₂ lasers (wavelength 10640 nm)

Uncolored and colored Ultramid® is practically impossible to mark with CO₂ lasers. At best there is only barely perceptible engraving of the surface without color change.

Printing

Printing on Ultramid® using conventional paper-printing methods requires no pretreatment. Injection-molded parts should be largely free of internal stresses and produced as far as possible without mold release agents, particularly those containing silicone. Special tried and tested inks are available for printing to Ultramid®.

Hot embossing

Ultramid® can be hot-embossed easily with suitable embossing foils.

Surface coating

Due to its outstanding resistance to most solvents, Ultramid® can be coated in one or more layers with various paints, which adhere well and have no adverse effects on mechanical properties. One- or two-component paints with binders matched to the substrate are suitable. Waterborne paints and primers can also be applied to Ultramid®. A mixture of isopropanol and water or other specific cleaning agents can be used for preliminary treatment. Industrial processes, such as preliminary treatment in automotive paint shops, are also suitable for cleaning. Coating based on electrostatics is only possible with what is known as a conductive primer as Ultramid® is not sufficiently conductive.

Metallizing

After proper pre-treatment, parts made of Ultramid® can be metallized galvanically or in a high vacuum. A flawless surface is achievable with both unreinforced as well as reinforced grades. Metallized parts made of Ultramid® are increasingly used in the sanitary, the electronics and automotive industries.



Laser marked test specimen

Conditioning

Ultramid® parts only achieve their optimum impact strength and largely constant dimensions after absorbing moisture. Conditioning, i.e. immersion in warm water or storage in warm, moist air, is used to increase the moisture content rapidly to 1 % to 3.5 %, the equilibrium moisture content of normal moist air (see Fig. 27 and individual values in the Ultramid® range chart).

Practical conditioning method

Immersion in warm water at 40 °C to 90 °C is simple to carry out but it can result in water stains, deposits and, especially in the case of thin parts with internal stresses, in warpage. Additionally, in the case of the reinforced grades, the quality of the surface can be impaired. Furthermore, conditioning of A3X grades in a waterbath at higher temperatures is not recommended.

Therefore, conditioning in a climatic chamber for rapid conditioning of specimens according to ISO-1110 (70 °C and 62 % relative humidity) is generally preferred as a gentle method. Here too, the temperature should not exceed about 40 °C for parts made from Ultramid® A3X.

Duration of conditioning

The speed of moisture absorption and thus the storage time required for conditioning increases sharply with the wall thickness of the parts (quadratic dependence), whereas it decreases significantly with increasing temperature.

At room temperature, moisture absorption is very slow. Therefore, a higher temperature is used when test specimens are to be conditioned in a short time. Table 10 contains the immersion times required for flat parts (sheets) of Ultramid® A and B as a function of the wall thickness and conditioning conditions, either in a moist climate or a water bath. Conditioning in a moist climate, e.g. at 70 °C/62 % r. h. is generally recommended as a thermally gentle conditioning climate.



Rear axle transmission cross beam

Annealing

Annealing, e. g., by heat treatment for 12 to 24 hours (in air or in an annealing liquid at 140 °C to 170 °C) can largely remove the internal stresses that occur in thick-walled parts made from highly reinforced Ultramid® grades (e. g. Ultramid® A3EG7) or in extruded semi-finished parts. In addition, annealing leads to post-crystallization of freshly molded and/or injection molded parts manufactured with cold tools. On the one hand this causes an increase in density, abrasion resistance, rigidity and hardness and on the other hand it gives rise to slight post shrinkage and sometimes a small amount of warpage.

| Ultramid® | Equilibrium moisture content in SC 23/50 [%] | Conditions | Thickness [mm] | | | | | | |
|--|--|------------|-----------------------------|------|-----|-----|-----|------|------|
| | | | 1 | 2 | 4 | 6 | 8 | 10 | |
| A grades unreinforced glass-fiber reinforced mineral-filled | 2.8 | Water bath | 40°C | 6 | 31 | 110 | 240 | 480 | 670 |
| | | | 60°C | 1.5 | 6 | 24 | 60 | 120 | 190 |
| | | | 80°C | 0.5 | 2 | 8 | 20 | 36 | 60 |
| | 1.2...2.2 1.4...1.5 | Atmosphere | 40°C/90% r.F. | 24 | 96 | 430 | 960 | 1700 | 2900 |
| | | | 70°C/62% r.F. ²⁾ | 15 | 60 | 240 | 550 | | |
| | B grades unreinforced glass-fiber reinforced mineral-filled | 3.0 | Water bath | 40°C | 3.5 | 14 | 60 | 120 | 240 |
| 60°C | | | | 1 | 4 | 16 | 36 | 72 | 110 |
| 80°C | | | | 0.5 | 1 | 4 | 10 | 18 | 24 |
| 1.5...2.6 2.0...2.4 | | Atmosphere | 40°C/90% r.F. | 15 | 60 | 260 | 600 | 1100 | 1700 |
| | | | 70°C/62% r.F. ²⁾ | 10 | 48 | 120 | 240 | | |

Table 10: Conditioning time in hours for setting the equilibrium water content in normally humid air (23 °C/50 % r.h.) when storing flat parts (sheets) made of Ultramid® in a hot water bath or in a humid climate

¹⁾ For values of the equilibrium water content of the various Ultramid® grades in SC 23/50, see the Ultramid® product range overview.

²⁾ According to ISO-1110 for conditioning of standard specimens to the normal moisture content in SC 23/50

General information

Safety notes

Safety precautions during processing

As far as the processing is done under recommended conditions (see the product-specific processing data sheets), Ultramid® melts are thermally stable and do not give rise to hazards due to molecular degradation or the evolution of gases and vapors. Like all thermoplastic polymers, Ultramid® decomposes on exposure to excessive thermal load, e.g. when it is overheated or as a result of cleaning by burning off. In such cases gaseous decomposition products are formed. Further information can be found in the product-specific data sheets.

When Ultramid® is properly processed, no harmful vapors are produced in the area of the processing machinery.

In the event of incorrect processing, e.g. high thermal stresses and/or long residence times in the processing machine, there is the risk of elimination of pungent-smelling vapors which can be a hazard to health. Such a failure additionally becomes apparent due to brownish burn marks on the moldings. This is remedied by ejection of the machine contents into the open air and reducing the cylinder temperature at the same time. Rapid cooling of the damaged material, e.g. in a waterbath, reduces nuisances caused by odors.

In general, measures should be taken to ensure ventilation and venting of the work area, preferably by means of an extraction hood over the cylinder unit.



Dry sump oil pan

Food regulations

The grades in the Ultramid® range marked FC are in principle suitable for use with food contact. Detailed information on the current food law status of the respective Ultramid® grades in various regions (e. g. EU, USA, China, Japan), as well as corresponding conformity confirmations, can be obtained on request from BASF (plastics.safety@basf.com).

Under the name Aqua®, Ultramid® grades are available that have different country-specific approvals for drinking water contact applications. All plastics in the Aqua® range have at least one approval according to KTW-BWGL¹⁾ DIN EN 16421: 2015-05, DVGW²⁾, and WRAS³⁾ in cold-water applications, and a large proportion of them for warm and hot water, too. In order to make it easier for the finished components to be approved, BASF provides all the declarations of conformity and test certificates required for Germany and Great Britain. If approvals are required from the certification bodies for drinking water and NSF⁴⁾ or other institutes, BASF will assist by providing formulation disclosures to the institutes. For questions regarding compliance with further regulations and declarations of conformity, please contact your local BASF representative or Plastics Safety (e-mail: plastics.safety@basf.com).

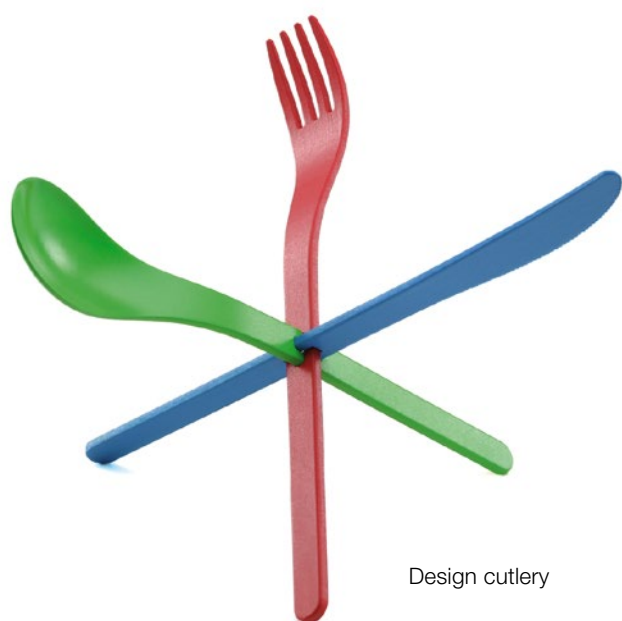

Sustainability

Responsible management of resources at BASF

BASF works with customers to provide sustainable products and solutions, which help to achieve sustainability targets and market differentiation. Engineering plastics such as Ultramid® can be produced efficiently and save resources during the lifetime of the components. To reduce CO₂ emissions during manufacturing, BASF is successively increasing the use of emission-free wind and solar energy at its sites. Production plants powered by fossil fuels are electrified and prepared for operation with renewable energy. In addition, BASF has set itself the objective of closing material cycles and making the best possible use of resources along the value chain.

Biomass Balance Approach

Renewable raw materials such as biomethane or bionaphtha from biowaste are fed into BASF's plants at the beginning of the complex multistage production process where they mix with fossil raw materials. The end product is chemically identical to the fossil standard product. With this biomass balance approach, BASF uses a process that allows our customer to buy a conventional product while saving fossil resources and reducing CO₂ emissions.



Saves fossil resources



Reduces greenhouse gas emissions



Promotes the use of renewable resources



Is independently certified



Ensures identical product quality and properties

¹⁾ KTW-BWGL: Kontakt mit Trinkwasser (Deutschland)

²⁾ ACS: Attestation de Conformite Sanitaire (Frankreich)

³⁾ WRAS: Water Regulation Advisory Scheme (UK)

⁴⁾ NSF: National Sanitation Foundation (USA)

ChemCycling®

A key pillar in using plastic waste as a new resource is ChemCycling®. Here, our partnerships focus on the chemical recycling using pyrolysis technology which turns plastic waste or end-of-life tires into a secondary raw material called pyrolysis oil. We feed the oil into BASF's Verbund production at the beginning of the value chain, thereby saving fossil resources. By using a third-party audited mass balance approach, the share of recycled feedstock is attributed to products manufactured in the Verbund. These mass balanced Cycled® products are independently certified and have the same properties as conventional products. Customers can therefore further process them in the same way and use them in demanding applications.

Product Carbon Footprint (PCF)

To create transparency on CO₂ emissions at the product level, BASF has developed the capability to calculate the CO₂ footprint for approximately 45,000 relevant sales products. Our in-house digital solution, SCOTT (Strategic CO₂ Transparency Tool), enables us to provide transparency for our customers and partners.

The Product Carbon Footprint (PCF) aggregates the total greenhouse gas emissions generated by a product throughout its life cycle. BASF's PCF calculation incorporates the "cradle-to-gate" phase and is based on GHG emission data from our own plants, high-quality average data, and supplier-specific data for purchased raw materials and energy. The method aligns with the calculation rules of the TfS guideline (Together for Sustainability), the chemical industry's standard for calculating product carbon footprint values. Additionally, the BASF method adheres to the relevant PCF standard ISO 14067:2018, and both the methodology and the digital solution have been certified by TÜV Rheinland.

Our unique integrated production setup significantly contributes to our leading product carbon footprints. By optimizing resource efficiency and minimizing waste, the Verbund structure allows us to achieve superior environmental performance, setting a benchmark in the industry.

Our various approaches to emission reduction have been compiled in a structured toolbox. For more information, please visit: plastics.basf.com/Green-Energy-Manufacturing.

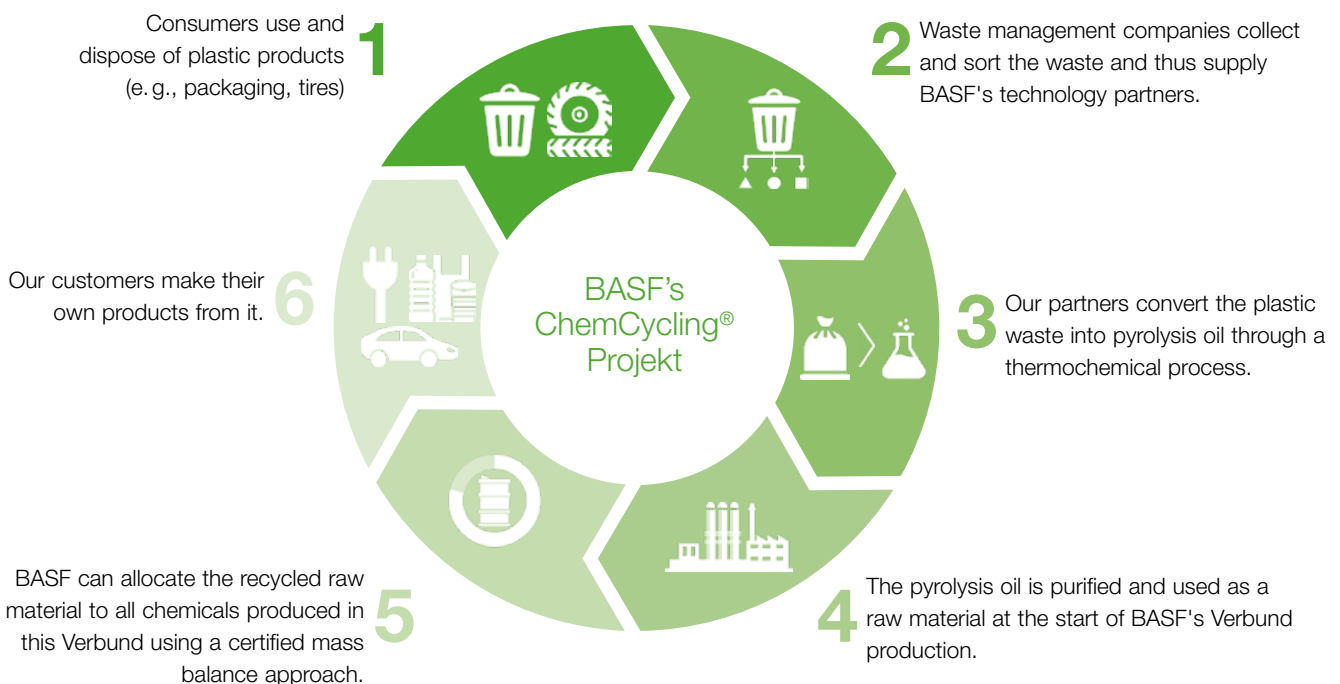

Fig. 46: BASF's ChemCycling® project

Delivery and storage

Ultramid® is supplied as granules. Standard packaging is the bag and the intermediate bulk container (IBC). Upon agreement, other packing materials and shipment via road or rail silo cars are possible.

Ultramid® is not classed as hazardous within the meaning of CLP Regulation (EC) no. 1272/2008 and is therefore not considered a dangerous good for transportation. Ultramid® is classified as non-hazardous to water. Further information can be found in the product safety data sheets.

Storage and transport

In principle, the product can be stored for a longer period of time. The containers should only be opened immediately before processing or drying. To ensure that the product supplied absorbs as little moisture as possible, the containers should be stored in dry rooms and always resealed immediately after partial quantities have been removed. Containers stored in cold rooms must be tempered before opening to prevent condensation from forming on the granules. The product should be pre-dried according to our recommendations, regardless of the storage conditions.

Ultramid® is supplied in both colored and uncolored form. A number of products are available in shades of black. Individual grades can be supplied in a variety of shades upon request. With light colors, a color shift can occur (yellowing) after longer storage periods and depending on the storage conditions.

Exceptions: The H and W stabilized Ultramid® grades as well as Ultramid® A3X grades are exceptions which can only be supplied in black or natural because their natural color does not permit colored pigmentation to a specific shade.

Other fillers, e.g. carbon fibers, can also affect the natural color.

Disposal

All Ultramid® grades can be incinerated in accordance with official regulations. The calorific value of unreinforced grades is 29,000 to 32,000 kJ/kg (Hu according to DIN 51900).

Recovery

Like other production wastes, sorted Ultramid® waste materials, e.g. ground up injection-molded parts and the like, can be fed back to a certain extent into processing depending on the grade and the demands placed on it. In order to produce defect-free injection-molded parts containing regenerated materials, the ground material must be clean and dry (drying is usually necessary). It is also essential that no thermal degradation has occurred in the preceding processing. The maximum permissible amount of regrind that can be added should be determined in trials. It depends on the grade of Ultramid®, the type of injection-molded part and on the requirements. The properties of the parts, e.g. impact and mechanical strength, and also processing behavior, such as flow properties, shrinkage and surface finish, can be markedly affected in some grades by even small amounts of recycled material.



Front-end carrier

Integrated management system

QHSE management

Quality, health, safety and environmental management are key elements of BASF's corporate policy. Our primary aim is to become even better at identifying and fulfilling our customers' needs. The continuous improvement of our products and services in terms of quality, safety, environment and health is a fundamental element of this.

BASF's Performance Materials Europe business unit uses an integrated management system for the Ultramid® products certified according to the following standards. The business unit is recognized by an accredited certification company for its:

- ISO 9001 (Quality management system)
- IATF 16949 (Automobile industry quality management standard)
- ISO 14001 (Environment management system) and
- ISO 50001 (Energy management system) or EMAS.

Services

BASF is more than a manufacturer of raw materials, able to deliver innovative plastics on time and to the required quality. We support and advise our customers on sustainable developments in many different application areas with application-specific know-how, technical service and simulations. We also have well equipped technical departments which specialize in processing technologies, material and component testing.

Ultrasim®

Ultrasim® is BASF's comprehensive and flexible CAE expertise with innovative BASF plastics. The modern calculation of thermoplastic components is very demanding for the developer. When it comes to the interaction between manufacturing process, component geometry and material, only an integrated approach can lead to an ideal component. Plastics reinforced with short glass fibers in particular have anisotropic properties depending on how the fibers perform in injection molding. Modern optimization methods support the component design and can improve it in every phase of its development.

Seat structure



BASF's integrative simulation incorporates the manufacturing process of the plastic component into the calculation of its mechanical performance. This is provided by a completely new numerical description of the material which takes the properties typical of the plastic into account in the mechanical analysis. These properties include

- Anisotropy
- Non-linearity
- Dependence on strain rate
- Tension-compression asymmetry
- Failure performance
- Dependence on temperature.

The new Ultrasim® thermomechanics module can also be used to simulate temperature-dependent deformations under any temperature load and distribution. A separate module for simulating thermally conductive plastics completes the Ultrasim® modeling portfolio.

With Ultrasim®, components can be designed specifically to meet specific requirements - for highly stressed, efficient, lightweight components and therefore for long-term market success.

Ultrasim® Web Services (<https://ultrasimweb.basf.com/>) provide BASF customers with easy access to Ultrasim® simulation technology and material modeling: The simulation app 'molded', for example, allows the manufacturability of injection molded parts to be calculated within seconds and the results to be shared with colleagues. By using Ultrasim® early in the part development phase, time and time and cost savings can be realized.

Ultratest® und Ultrajoin®

Ultratest® represents the many different competences and activities which support our customers with component analysis and optimization through experimental methods.

Ultrajoin® contains our comprehensive know-how and our unique infrastructure for bonding techniques.

Support, which is available worldwide, makes an important contribution in all phases of development – from the material, and application development through simulation to component analysis for series production.

If necessary, the extensive equipment can be adapted or new test set-ups can be developed to ensure that tests meet the customer-specific requirements. Live transmissions allow our customers to take part in the tests without having to be in the BASF laboratory.

The test options in the context of component analyses include e. g.:

- Temperature, temperature shock and climate tests, including in an inert atmosphere
- Chemical stability tests
- Quasi-static, dynamic and impact tests with external forces or internal pressures
- Vibration analyses, acoustic analyses
- Flow and leak tests
- Non-destructive testing with computer tomography
- Digital geometry, deformation and strain measurements
- Temperature field analyses with IR thermograph
- Documentation of all transient processes with high-speed cameras
- Testing, evaluation and optimization of all relevant joining methods (see also Joining methods chapter)
- Laser transparency and laser markability analyses

Torque rod support



Nomenclature

Structure

The name of Ultramid® commercial products generally follows the scheme below:



Subnames

Subnames are optionally used in order to particularly emphasize a product feature that is characteristic of part of a range.

Examples of subnames:

| | |
|----------|-----------------|
| Advanced | Polyphthalamide |
| Expand | Particle foam |

Technical ID

The technical ID is made up of a series of letters and numbers which give hints about the polymer type, the melt viscosity, the stabilization, modification or special additives and the content of reinforcing agents, fillers or modifiers. The following classification scheme is found with most products:

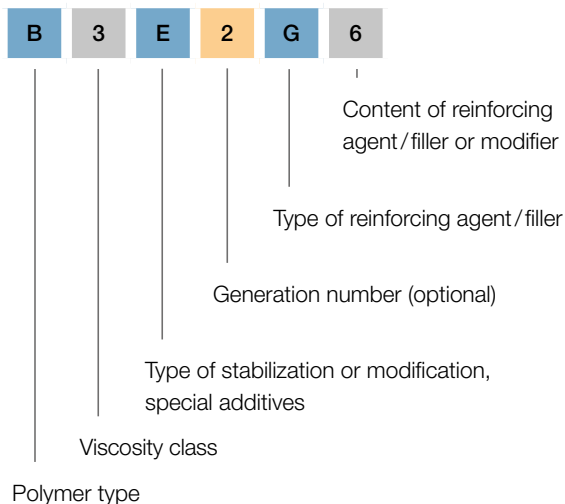

Ultramid® T KR generally has the following classification scheme:

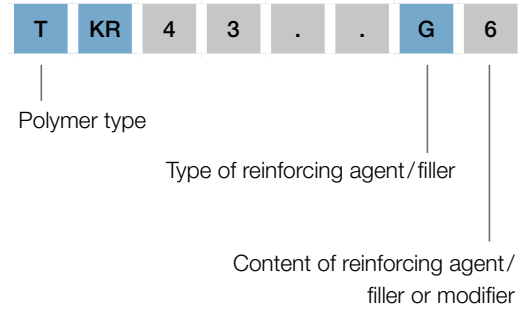

Letters for identifying polymer types

- A Polyamide 66
- B Polyamide 6
- C Copolyamide 66/6
- D Special polymer
- F PA6/636
- N Polyamide 9T
- S Polyamide 610
- T Copolyamide with 6T
TKR Copolyamide 6T/6
T1... Copolyamide 6T/6I
T2... Copolyamide 6T/66

Numbers for identifying viscosity classes

- 3 Free-flowing, low melt viscosity, mainly for injection molding
- 35 Low to medium viscosity, for injection molding processing and certain types of extrusion processing
- 4 Medium viscosity, for injection molding and extrusion processing

Letters for identifying stabilization

- E, K Stabilized, light natural color, increased heat-aging, weather and hot water resistance, electrical properties are not impaired
- H Stabilized, increased heat-aging, hot water and weather resistance only for engineering parts, electrical properties remain unaffected, depending on the grade light-beige to brown natural color
- W Stabilized, high resistance to heat-aging, can only be supplied uncolored and in black, less suitable if high demands are made on the electrical properties of the parts
- P Stabilized, very high heat aging resistance, good weathering and hot water resistance, electrical properties are not affected

Letters for identifying special additives

| | |
|---|---|
| L | Impact-modified and stabilized, impact resistant when dry, easy flowing, for rapid processing |
| S | For rapid processing, very fine crystalline structure, for injection molding |
| U | With flame-retardant finish without red phosphorus |
| X | With red phosphorus as the flame-retardant finish |
| Z | Impact-modified and stabilized with very high low-temperature impact strength (unreinforced grades) or enhanced impact strength (reinforced grades) |

Letters for identifying reinforcing agents/fillers

| | |
|----|--|
| C | Carbon fibers |
| G | Glass fibers |
| K | Glass beads |
| M | Minerals |
| GM | Glass fibers in combination with minerals |
| GK | Glass fibers in combination with glass beads |

Key numbers for describing the content of reinforcing agents/fillers or modifiers

| | |
|----|----------------------|
| 2 | approx. 10 % by mass |
| 3 | approx. 15 % by mass |
| 4 | approx. 20 % by mass |
| 5 | approx. 25 % by mass |
| 6 | approx. 30 % by mass |
| 7 | approx. 35 % by mass |
| 8 | approx. 40 % by mass |
| 10 | approx. 50 % by mass |

In the case of combinations of glass fibers with minerals or glass beads, the respective contents are indicated by two numbers, e. g.

| | |
|------|--|
| GM53 | approx. 25 % by mass of glass fibers and approx. 15 % by mass of minerals |
| GK24 | approx. 10 % by mass of glass fibers and approx. 20 % by mass of glass beads |

Suffixes

Suffixes are optionally used in order to indicate specific processing or application-related properties. They are frequently acronyms whose letters are derived from the English term.

Examples of suffixes:

| | |
|-------|--|
| Aqua® | Meets specific regulatory requirements for drinking water applications |
|-------|--|

| | |
|-----|--|
| BAL | Based at least partly on renewable raw materials |
| BM | Blow molding grade |
| CR | Crash Resistant |
| DC | Durable Color, heat-ageing resistant paint |
| ESD | Electrostatic Discharge, electrostatically dissipative |
| EQ | Electronic Quality |
| FC | Food Contact; meets specific regulatory requirements for applications in contact with food |
| GIT | Gas Injection Technology |
| GP | General Purpose |
| GPX | New Generation "General Purpose" |
| HSP | High Speed, High flowability of the melt |
| HP | High Productivity, for high throughputs and short cycle times |
| HPP | High Productivity Plus |
| HR | Hydrolysis Resistant, increased hydrolysis resistance |
| HRX | New generation of HR product |
| LS | Laser Sensitive, can be marked with Nd:YAG laser |
| LT | Laser Transparent, can be penetrated well with Nd:YAG lasers and lasers of a similar wave-length |
| RC | Products with recycle content: RCX YZ; X=1 for consumer waste, X=2 for industrial waste, YZ for the proportion in the compound, e. g. Ultramid® B3WG6 RC2 30 UN for 30 % recycle in relation to the compound |
| SI | Surface Improved, for parts with improved surface quality |
| ST | Super tough |
| WIT | Water Injection Technology |
| XP | Extra mechanical performance, increased stiffness and strength |

Color

The color is generally made up of a color name and a color number.

Examples of color names

- Uncolored (Short form: UN)
- Black 00464 (Short form: SW00464; English: black 00464, Short form: BK00464)
- Black 00564 (SW00564; black 00564, BK00564)
- Black 20560 (SW20560; black 20560, BK20560)

Subject index

- Aftershrinkage 56 ff.
- Annealing 65
- Automotive applications 4 f.

- Behavior on**
 - exposure to weather 46
 - heat 32
- Behavior under
 - cyclic loads 31
 - flexural fatigue strength 31
 - long-term static loading 30
- Biomass Balance Approach 67

- Chassis and engine mounting 4**
- ChemCycling® 68
- Chemical and physical foaming 60
- Combustion engine and transmission 4
- CO₂ lasers 62
- Cooling system 4
- Conditioning 64
- Construction industry 38
- Consumer goods 8 f.

- Delivery and storage 69**
- Dimensional stability 34 f.
- Disposal 69
- Drying 49
- Duration of conditioning 64

- Electrical engineering 38**
- Electrical properties 36 f.
- Electrical systems 4
- Electrical and electronics sector 6 f.
- Electrified powertrain 4
- Electronics 6
- eMobility 6
- Excimer lasers 62
- Exterior 4

- Fire behavior 38 f.**
- Flow behavior 55
- Fluid injection technology (FIT) 59
- Food regulations 67
- Fuel system 4
- Furniture & Design 8

- General information 66**
- General notes 38
 - on processing 49
- Glass bead-filled Ultramid 13
- Glass-fiber reinforced Ultramid® 12

- Halogen content 38**
- Heat-aging resistance 33
- Heat-aging resistance in
 - coolants 34
 - hot lubricants 34
 - solvents 34
- Holding pressure 55
- Household 8 f.
- Household goods 8
- Hot embossing 63

- Impact strength 29 f.**
- Injection mold 51 f.
- Injection molding 53 ff.
- Injection rate 54
- Integrated management system 70
- Interior 4

- Joining methods 62**

- Laser marking 62**
- Leisure industry 8
- Low-temperature impact strength 29 f.

- Machine technique for injection molding 50 ff.**
- Machining 61
- Marking and coating 62
- Mechanical properties 26 ff.
- Melt viscosity 48
- Melting behavior 47
- Metallizing 63
- Mineral-filled Ultramid® 13
- Mold technique for injection molding 50 ff.
- Multi-component technology 59

- Nd-YAG lasers** 62
- Nomenclature** 72 f.
- Overmolding of Inserts** 60
- Photovoltaics** 6
- Plasticizing unit** 50 f.
- Polyphthalamides** 18
- Power technology** 6
- Practical conditioning method** 64
- Preliminary treatment** 49
- Printing** 63
- Processing** 47 ff.
- Processing characteristics** 47 f.
- Processing on steam molding machines** 61
- Processing temperatures** 53
- Product Carbon Footprint (PCF)** 68
- Product range** 10 ff.
- Properties** 26 ff.
- QHSE management** 70
- Recovery** 69
- Recycled content** 12
- Recycling** 49
- Reinforced grades with flame retardants** 12
- Reprocessing** 49
- Resistance to chemicals** 40 ff.
- Responsible management of resources at BASF** 67
- Safety notes** 66
- Safety precautions during processing** 66
- Sanitary services** 8
- Screw speed** 54
- Self-coloring** 49
- Semi-aromatic polyamides (PPA)** 18
- Services** 70
- Setting behavior** 47
- Shrinkage** 56
- Special processes** 59
- Storage** 69
- Sustainability** 67
- Surface coating** 63
- Tests**
- Construction industry 38
 - Electrical engineering 38
 - Transportation 38
- Thermal properties** 32 ff., 48
- Thermostability of the melt** 48
- Tough modified Ultramid** 12
- Transport** 69
- Transportation** 38
- Tribological behavior** 31
- Ultrajoin®** 71
- Ultramid® A** 11
- Ultramid® Advanced N** 11, 18
- Ultramid® Advanced T1000** 11, 18
- Ultramid® Advanced T2000** 11, 18
- Ultramid® B** 11
- Ultramid® C** 11
- Ultramid® D** 11
- Ultramid® Expand** 11, 24
- Ultramid® HPP** 25
- Ultramid® S Balance** 11, 22
- Chemical and hydrolysis resistance 22 f.
 - Mechanical properties 22
- Ultramid® T KR** 11, 19 f.
- Chemical resistance 20
 - Mechanical properties 19 ff.
 - Shrinkage and warpage 20
- Ultramid® T6000** 11, 22
- Performance between PA66 and PPA 22
- Ultramid® T7000** 11, 22
- Ultramid® Structure LFX** 11
- Ultramid® Vision** 24
- Ultrasim®** 70 f.
- Ultratest®** 71
- Unreinforced grades with flame retardants** 13
- Warpage** 55
- Water absorption** 34



PACIFIC – The **automated platform solution** streamlines the provision and receipt of **Product Carbon Footprint (PCF) data across the entire value chain**, significantly **reducing manual work**. It translates the benefits of BASF's SCOTT PCF calculation tool to the n-Tier chain, ensuring **trust-worthy and immutable data exchange** for seamless sharing with partners. Additionally, this solution can be integrated with other systems within the **Catena-X ecosystem**.



Note

The data contained in this publication are based on our current knowledge and experience. In view of the many factors that may affect processing and application of our product, these data do not relieve processors from carrying out own investigations and tests; neither do these data imply any guarantee of certain properties, nor the suitability of the product for a specific purpose. Any descriptions, drawings, photographs, data, proportions, weights etc. given herein may change without prior information and do not constitute the agreed contractual quality of the product. It is the responsibility of the recipient of our products to ensure that any proprietary rights and existing laws and legislation are observed. (October 2025)

Please visit our websites:

www.plastics.basf.com
www.plastics.basf.de

Request of brochures:

plas.com@basf.com

If you have any technical questions about the products, please contact the Infopoints:

