



We create chemistry

How flame-retardant plastics contribute to electric vehicle safety

And what you should know

emobility-plastics.basf.com



How flame-retardant plastics contribute to electric vehicle safety

EXECUTIVE SUMMARY			4
WHY DO FIRES NEED TO BE CONTAINED IN ELECTRIC CARS?	Principles: ignition and fire development	5	5-7
	Use case electric vehicles	6	
FOCUS APPLICATIONS			8-9
FLAME RETARDANCY SYSTEMS USED IN BASF'S PRODUCT PORTFOLIO			10
STANDARDIZATION AND RATINGS	Parameters for describing the fire behavior	12	11-15
	Measures after fire incidents	12	
	Side effects of fire	13	
	Measures after fire incidents	15	
TESTING	Electrotechnical applications	17	16-23
	Materials testing	18	
LITERATURE			24



BASF experts are always available to provide assistance in case of specific, more in-depth questions, also regarding the topics that have not been dealt with here.

[Contact us](#)

Executive Summary

Thanks to their multifaceted application possibilities, plastics have become an indispensable fixture of modern life. They make tremendous contributions to our quality of life and comfort, to technology and progress, to aesthetics, and to our well-being.

In many applications, plastics are key materials in driving forward eMobility. Due to their functional integration and lightweight properties, plastics provide many benefits to automotive engineers solving technical challenges that can hardly be met with metals.

New application fields for plastics are directly related to future powertrain trends which strive to reduce CO₂ emissions.

However, the electric powertrain challenges plastics with new property requirements since an electric setup raises different hazards than a combustion powertrain. While it has been higher temperatures and chemical resistance against fuel and other lubricants in the past, the new powertrains demand a higher safety against electric malfunctions, which can cause the risk of an electric shock, the occurrence of electric arcs, and other potential sources of ignition.

Since plastics are mainly combustible materials, special precautions have to be taken to increase electric vehicle safety and to prevent the ultimate worst-case scenario of a battery cell fire, a so-called thermal runaway.

That is why flame-retardant polymer compounds should be considered as one of your choices for a safer electric powertrain.

Application fields for plastics for electric vehicle and charging infrastructure

Connectors, cables, and cable management

Battery components

Thermal management

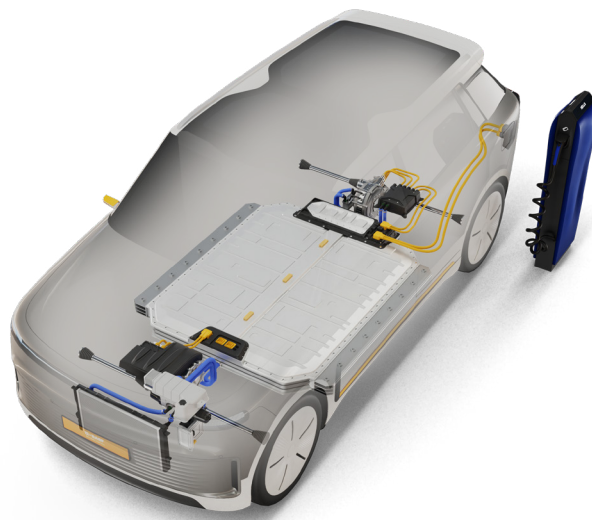

Charging infrastructure

Electric powertrain

Electric motor

NVH solutions

Why do fires need to be contained in electric cars?

Principles: ignition and fire development

The start of a fire and its spread are determined primarily by the size, type and position of the source of ignition as well as by the form and specific properties of the flammable material. The combination with other materials as well as the production and ambient conditions also influence the fire behavior.

A fire often develops according to certain patterns. Seekamp² and Becker³ have extensively studied and described fire incidents in rooms: After the flammable product has ignited, the flames normally spread in the form of fire appearing on the outer surface of the product.

Once the initially ignited material has generated enough heat, additional areas are affected by the fire.

The fire spreads even more quickly whenever more heat is generated that elevates the room temperature and, through heat radiation, heats up and destroys the material surfaces that are close to the fire (phase of the starting fire). After a certain time, the gases released in this process reach ignitable concentrations, so that the fire can abruptly engulf the entire volume.

This flash-over marks the beginning of the fully developed fire. The spread of the fire to zones outside of the room depends on the fire resistance of the structural elements surrounding the room. Once the fire has passed its peak in the room, the phase of the subsiding fire starts, during which the flammable materials in the room burn out more or less completely.

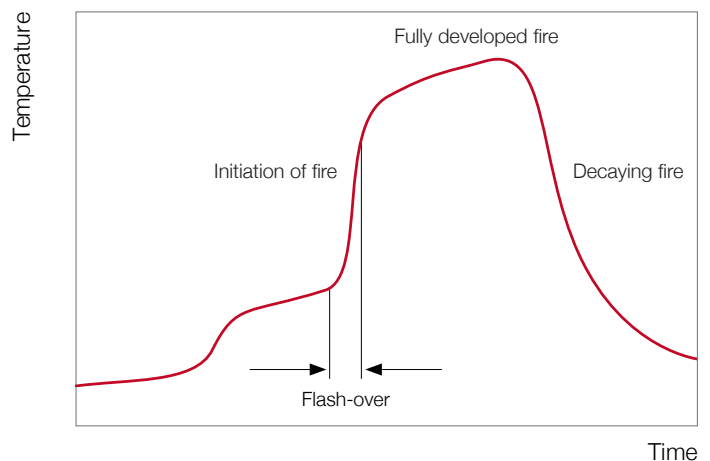

Fig. 1: Phases of the fire development in rooms according to Becker³

Use case electric vehicles

In modern transportation engineering, plastics make a substantial contribution to the high-level performance of cars, trains, busses and airplanes.

Whereas the focus used to be primarily on economic considerations, nowadays there is great demand for plastics when it comes to meeting further requirements such as better road safety, reduction in weight, an attractive design or greater comfort. As such, plastic materials have been also under review for their flammability.

Investigations into the cause of vehicle fires have shown that a large proportion of these fires start in the engine compartment. One example of a major cause is combustible materials such as fuel or lubricants being ignited on hot surfaces. But fires can also be caused by electrical faults associated with sparking or overheating. However, this hazard can be effectively prevented by choosing suitable materials and constructive measures.

In the past, the focus was especially on interior materials to prevent a hazardous situation for the passengers. Until today, such interior materials must display a low risk of ignition and flame propagation speed. This is intended to ensure that there is a sufficient amount of time to stop a vehicle even at high speed and exit the vehicle in good time.

The test procedure, which has been introduced in the USA as the Federal Motor Vehicle Safety Standard (FMVSS 302), has been adopted by many other standards (e.g. DIN 75200 and ISO 3795) and the delivery specifications of most car manufacturers around the world.

After exposing the horizontally arranged test specimen to a Bunsen burner flame for 15 seconds, the propagation speed of the flames is determined. The highest permitted value is 4 inches/min or 102 mm/min. The measured propagation speed of the flames is dependent on the thickness of the test specimen.

Simple visualization of fire stages



Ignition

The initiation of a combustion is a short term process

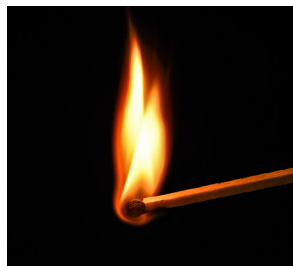

Combustion

The act or process of burning

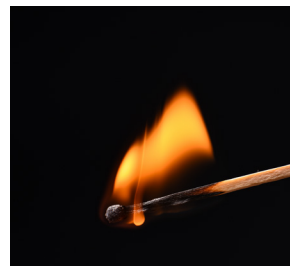

Flame spread

The propagation of a flame from its ignition source



Flame extinction

The process of putting out a visible flame

Most of BASF's engineering plastics meet the requirements at thicknesses of 1 millimeter. However, the rising number of electrical components with high power output is increasing the demand for flame-retardant thermoplastics.

The test scenario of the FMVSS 302 cannot be compared to a battery fire of an electric car. At high temperatures, the metal oxides in lithium-ion cells disintegrate by releasing oxygen which results in an exothermic reaction. This reaction could only be stopped by massive cooling. Most likely on the road, it cannot be controlled anymore – a thermal runaway is a result.

With the popularity of electric cars and the potential danger from thermal runaways, the automotive industry headed to different standards that were mainly designed for stationary E/E applications. Those standards are mainly described in the Underwriters Laboratories Standards UL94 and UL746 (see Standardization and ratings). The intention for applying these standards is to prevent that an electric malfunction causes a fire from parts in the vicinity of the battery cells. With appropriate materials in place — one that are resistant against short-time ignition sources — the outbreak of a battery cell fire triggered by external malfunctions is less likely. The sources of ignition in E&E are typically high current arcs, hot wires, and fusing transistors or capacitors.



When a thermal runaway is ongoing, flame-retardant plastics cannot stop it, but they can make thermal runaway events less likely.

Switchgear



Focus applications

Flame-retardant plastics are useful for the following eMobility applications:

- In the vicinity of sensitive materials, such as battery cells to prevent thermal runaways
- Components with a high potential of ignition due to nearby electric currents such as breakers and switches.
- In EVC-Cables (cable-sheathings) for increased safety and prevention of an fire propagation



We are happy to help you determine which flame-retardant product is best suited for your specific application.

[Contact us](#)

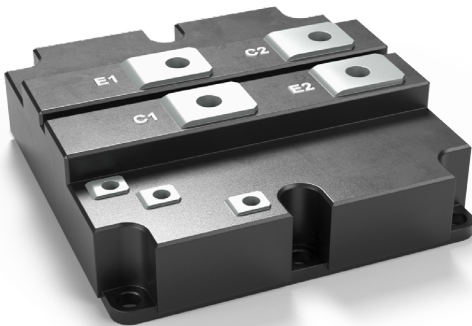

Insulated-gate bipolar transistor (IGBT)



Charging infrastructure &
Electric Vehicle Charging (EVC) Cables

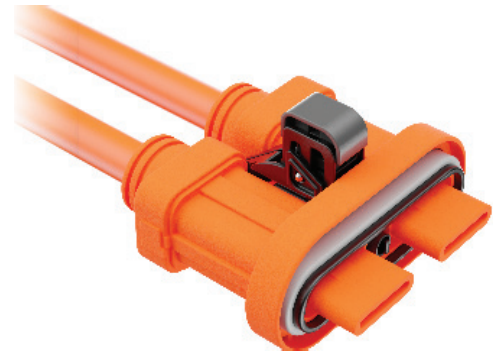

Connectors, cables & cable management

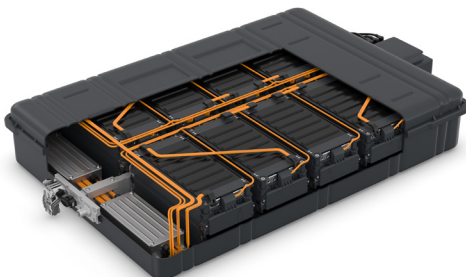

Battery components

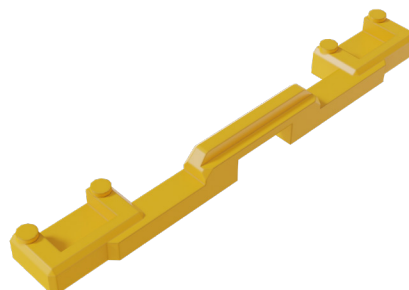

Busbar holders

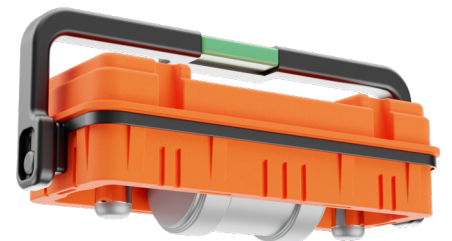

Electric switches, breakers, fuse holders

Flame retardancy systems used in BASF's product portfolio

	Halogens	Red phosphor	Organic / inorganic phosphor	Melamine derivatives	Magnesium hydroxide	Inherent flame protected
+	<ul style="list-style-type: none"> High efficiency 	<ul style="list-style-type: none"> Good electrical properties Best mech. prop. Impact modification possible High efficiency Low density 	<ul style="list-style-type: none"> Good electrical properties Light colors possible 	<ul style="list-style-type: none"> Good electrical properties Light colors possible High toughness 	<ul style="list-style-type: none"> Good electrical properties Light colors possible Low smoke density High thermal conductivity 	<ul style="list-style-type: none"> No additives necessary
-	<ul style="list-style-type: none"> High smoke density Antimony trioxide (ATO) as synergist needed Corrosivity of smoke gas Low CTI Risk of toxic degradation products 	<ul style="list-style-type: none"> Only dark colors Not suitable for hot/humid climates Contact deposit possible (critical for low current applications) 	<ul style="list-style-type: none"> Higher abrasion in plasticizing unit Special processing recommendations need to be obeyed 	<ul style="list-style-type: none"> Limited efficiency in reinforced compounds 	<ul style="list-style-type: none"> High amount of FR additives needed High density of compound Low toughness 	

BASF's flame-retardant product portfolio Ultradur®, Ultramid® and Ultrason®

	Halogens	Red phosphor	Organic / inorganic phosphor	Melamine derivatives	Magnesium hydroxide	Inherent flame protected
Ultradur®	B 4406 B 4406 G2 B 4406 G4 B 4406 G6 B 4406 G6 Highspeed		B 4440 Exp. B 4440 G2 Exp. B 4440 G4 B 4441 G5 B 4450 G5 HR			
Ultramid®		A3X2G5 A3X2G7 A3X2G10 A3XZG5 A3XZC3 TKR 4365G5	A3UG5 A3U42G6 Exp. B3U42G4 B3U41G6 B3U42G6 B3U50G6 TKR 4340G6 TKR 4341G6 Advanced T2340G6 Advanced N3U41G6	B3U B3UG4 B3U31G4 B3U30G6 C3U C3UG4	B3UGM210 KR 4450	
Ultrason®						E2010 MR E2010 MR BK E2010 MR BK HM E2010 G4 E2010 G6 E0510 G9 DIM



Flame-retardant polymers show self-extinguishing properties to a certain extent and thus increase safety in electric applications.

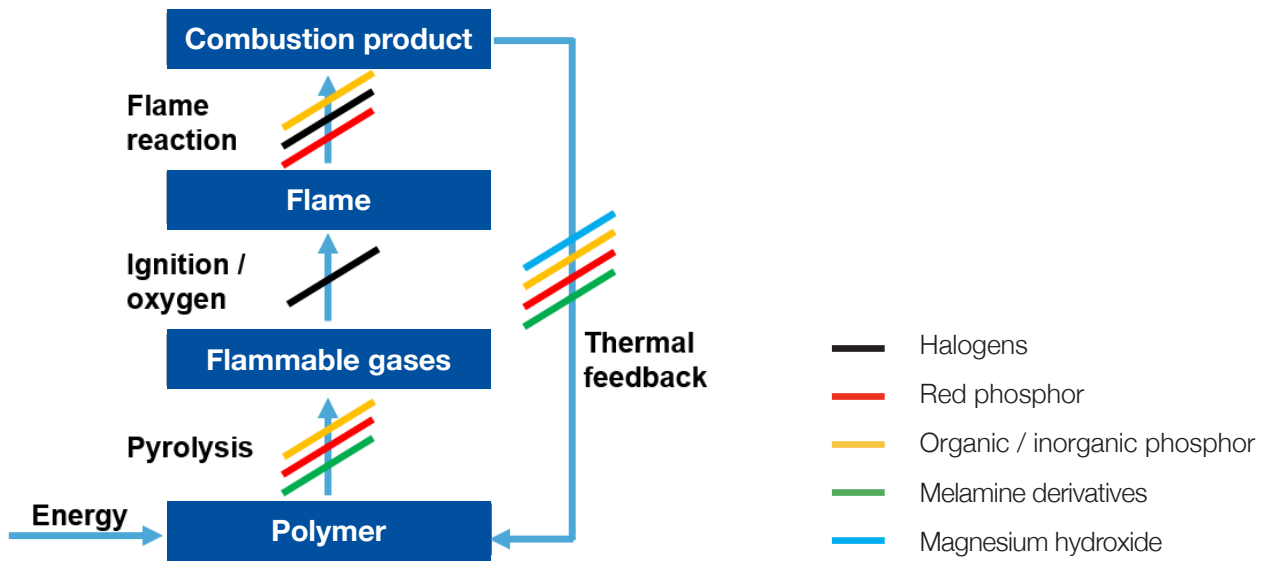

Mode of action of the flame retardant additives at the different flame stages.



Standardization and ratings

In a joint effort with users and many organizations involved in fire safety, BASF provides the necessary prerequisites for the safe and reliable utilization of its products.

For instance, the fire-retardant Ultramid® and Ultradur® grades (PA and PBT, respectively) were developed paying close attention to the aspects of product and application development, the environment and the market.

Through BASF's participation in fire-safety commissions, new material-related requirements are recognized at an early point in time and implemented accordingly.



Battery disconnect unit



Fig. 2: Accredited BASF test laboratory in accordance with **DIN EN ISO/IEC 17025¹**

Parameters for describing the fire behavior

A fundamental presentation on the topic of the fire behavior of plastics can be found, for example, in Troitzsch⁴.

The characteristic parameters for the fire behavior are: ignitability contribution to flame spread heat release. The side effects of fire are:

- flaming drips/falling material
- smoke generation (optical density and toxicity)
- toxicity of fire residues
- corrosiveness of combustion gases
- fire residues

Fire tests are necessary in order to evaluate and rate the fire behavior. These tests should be representative and should closely reflect the situation of the fire hazard. Such tests are often conducted with test specimens having defined dimensions and under reproducible initial and boundary conditions. The objective of such tests is to ascertain comparable product-specific characteristic values.

However, since the fire behavior is not based only on the actual material properties, tests also have to be carried out on complete structures or component under conditions that are relevant for actual practice.

Fire tests are necessary in order to evaluate and rate the fire behavior. These tests should be representative and should closely reflect the situation of the fire hazard. Such tests are often conducted with test specimens having defined dimensions and under reproducible initial and boundary conditions. The objective of such tests is to ascertain comparable product-specific characteristic values.

However, since the fire behavior is not based only on the actual material properties, tests also have to be carried out on complete structures or component under conditions that are relevant for actual practice.

Ignitability and flame spread

The ignition initiates a combustion process. Ignition presupposes heating and decomposition of the burning materials in the area of action of the source of ignition. Thermoplastics soften when exposed to heat (glass transition, crystallite melt), and as the temperature continues to rise, they turn into a melt that gives rise to the flammable decomposition products. Once these products mix with the oxygen present in the air, the ignition can occur as self-ignition or external ignition at concentrations within the ignition limits and in the presence of sufficiently high energy.

In contrast to flammable liquids, when it comes to engineering plastics, like with all other flammable solid materials, it is not possible to indicate a flash point. Testing according to **DIN 54836**⁵, yields ignition temperatures under exposure to flames of about 350° C to 400° C [662° F to 752° F]. Without exposure to flames, the thermal decomposition products only ignite at temperatures that are higher by about 50° C to 100° C [90° F to 180° F].

Combustion is an exothermal process. Part of the energy being released in the combustion zone is consumed to generate heat and to form flammable decomposition products. This process is called thermal feedback from the combustion zone to the heating zone. The ratio of the available amount of energy to the amount of energy needed to generate heat and to form flammable decomposition products determines the extent of flame spread on the surface of the flammable material. Therefore, flame spread can be considered to be a sequence of ignition processes.

Aside from the chemical make-up of the flammable material and its physical properties, for example, the viscosity of the melt, the course and scope of these processes are also influenced by additives such as stabilizers, colorants and lubricants. Insofar as a given plastic is not sufficiently inherently flame-retardant, which is the case, for instance, with Ultrason[®], the fire behavior can be improved by the addition of flame retardants, thus considerably reducing the contribution to the spread of the fire. Ignition can nevertheless occur here in the case of high-ignition energies that are active for a prolonged period of time.

However, the burning is usually restricted to the direct range of action of the ignition source. Here, too, the rate of spread of the flames is much lower than for plastics without a fire-retardant finish. As soon as contact with the source of ignition is interrupted, the flames usually self-extinguish, especially in the early stages of a fire. Inherently flame-retardant plastics and those with a fire-safety finish often attain the best possible ratings for flammable materials.

Side effects of fire

For purposes of describing the fire development, it is important to know the heat release. The heat release is dependent on the combustion rate of the burning material under the present fire conditions or the fire scenario. During a fire, the maximum heat quantity that can be released is the one corresponding to the heat of combustion. The heat of combustion is the released amount of heat released under standardized conditions — with the complete combustion of a material — minus the heat of evaporation of the water that is formed. Since the combustibility or the burning behavior is dependent on many influencing variables, the net calorific value of a material cannot be regarded as a measure of its combustibility in the conventional sense. Table 1 is a compilation of net calorific values according to **DIN 51 900-1⁶** of commonly employed thermoplastics.

Material	Hu (kJ/kg)
Polyoxymethylene (POM)	17,000
Polyethersulfone (PESU)	17,000
Polyvinyl chloride (PVC)	20,000
Polymethyl methacrylate (PMMA)	26,000
Polybutylene terephthalate (PBT)	31,000
Polyamide (PA)	32,000
Polysulfone (PSU)	36,000
Styrene Copolymers (ASA, ABS, SAN)	37,000
Polystyrene (PS)	42,000
Polyolefins (PP and PE)	46,000

Tab. 1: Net calorific values of thermoplastics

Smoke generation

Every fire generates gases as well as solid and/or liquid decomposition and secondary products of varying compositions. The liquid products are primarily water, while the solid products are soot. The term smoke is used when the combustion gases contain solid and/or liquid particles. This gives rise to various risks: smoke can reduce visibility as well as have a toxic and corrosive effect.

Smoke density

The optical density of the smoke determines the visibility conditions, thus affecting the possibilities of escape in case of a fire. In order to measure the smoke density, the principle of light extinction is normally employed: the weakening of a light beam of a known intensity caused by the smoke constitutes a measure of its optical density. Static (cumulative) as well as dynamic methods are employed for smoke measurement. The various test methods also differ in terms of the type of decomposition and the volume of oxygen available. Therefore, the values ascertained using different test methods cannot be compared to each other.

Toxicity

Combustion gases and fire residues stemming from plastics – like natural substances – always entail a toxic potential. In many cases, certain measures can prevent persons from being injured as a result of inhaling combustion gases. These measures include, in particular, restricting the ignitability and flame spread, the creation of escape routes and smoke and heat exhaust systems as well as fire detection and fire-fighting. If escape possibilities are limited or nonexistent (for example, in trains as they pass through tunnels, in airplanes, in ships), the composition of the combustion gases is often considered to be a safety-relevant aspect.

It is not only the materials involved that determine the toxicity of the combustion gases. The fire scenario (e.g. temperature, availability of oxygen) likewise has a major influence. The essential components of all combustion gases are carbon dioxide, water and carbon monoxide resulting from incomplete combustion. The concentration ratios are influenced by the fire conditions. The content of carbon monoxide often determines the acute inhalation toxicity of the combustion gases. Carbon monoxide is almost always formed in sufficient amounts and quickly enough – in comparison to other components of the combustion gas – to be the first to exceed the lethal limit value. In individual cases, however, other combustion gas components can also pose a risk.

A wide array of other substances can be generated as byproducts and can have a sub-lethal effect. For estimating the toxic potential, the concentration of relevant components in the combustion gas is compared to a known limit concentration. The IDLH (Immediately Dangerous to Life and Health) values often serve as the basis. It is assumed that escape is possible within 30 minutes if the IDLH values are not exceeded.

In order to make prognoses, Haber's rule is normally used: "If the product of the concentration and time remains the same, then the effect is the same." Consequently, the effective exposure dose for each gas component is defined as the product of the IDLH value (concentration) and the basic time of 30 minutes (Table 2).

The exposure dose can be calculated as the product of concentration and test time on the basis of the combustion gas concentrations measured during the course of the fire tests. The size of the specimen, the volume of the test chamber and the geometrical circumstances in the intended final application are all taken into consideration using a scale factor. The so-called fractional effective exposure dose (FED) is then determined as follows:

$$\text{FED} = \frac{\text{existing exposure dose}}{\text{effective exposure dose}} = \int \frac{c(t)}{Ct_{\text{eff}}} dt$$

In other words, the measured exposure dose is compared to the effective exposure dose for the appertaining gas component. If the FED is less than 1, it can be assumed that survival or the ability to escape is ensured within the time under consideration.

For an approximate estimation of the total risk from all of the combustion gas components, a cumulative effect of the components found in the fire test is assumed. The total of the FED values for each component thus yields an FED_{total}. Corrosiveness Combustion gases of many organic substances have a corrosive effect, and combustion gases stemming from natural substances are no exception to this.

For example, the combustion gases from wood contain acetic acid. As a rule, combustion gases released by engineering plastics do not exhibit corrosiveness or have an irritating effect on the skin and respiratory tract that goes beyond the normal scope. If they have a fire-retardant finish containing halogen, then the corrosiveness and irritant effect can be stronger.



Gas component	IDLH-Value [mg/m ³]
CO ₂	72,000
CO	1,380
HF	25
HCl	75
HBr	99
HCN	55
NO ₂	38
SO ₂	262

Tab. 2: IDLH values from NIOSH⁷



Junction box

Measures after fire incidents

Firewater thermoplastics, like many other materials, are water-insoluble and are not considered to be hazardous to water. Consequently, there are no statutory stipulations requiring that the extinguishing water has to be contained. For reasons having to do with preventive water and soil protection, even when substances are stored that are not hazardous to water, it can still be advisable to take precautions to contain the accumulated extinguishing water, so that it cannot get into open bodies of water, groundwater or the soil.

Generally speaking, the competent authorities do not object to the discharging of extinguishing water from fires involving plastics into sewage-treatment plants. In this context, however, it should be kept in mind that plastics are often involved in the fire along with other materials, for example, the contents of containers. These might be hazardous to water. Moreover, in cases of fire, the fire department often employs special extinguishing agents, for instance, foams, some of which are classified as hazardous to water. In such cases, special precautions are required and there is a need to consult with competent authorities.

Ecotoxicity studies carried out at the University of Wuppertal, Germany, on extinguishing water from various sources have revealed that extinguishing water used in fires involving plastics does not entail a higher hazard potential than extinguishing water from fires where no plastics are involved (Pohl et al.⁸). Fire residues have to be collected and disposed of in accordance with the statutory regulations applicable to the waste disposal, and in consultation with the competent authorities.

Testing

Technical fire-protection requirements are safety requirements. They are always oriented toward the specific conditions of use, hazard potentials and associated safety objectives. Depending on the area of application, these requirements can vary widely.

The primary safety objective in many technical areas of application consists of preventing materials from catching fire due to possible sources of ignition such as a smoker or arsonist. Sources of ignition stemming from technical defects should also be taken into account. Thus, low ignitability of the flammable material is an essential fire-safety requirement. Should ignition occur nevertheless, then the contribution to the flame spread as well as to the generation of heat and smoke should not exceed tolerable limit values.

Therefore, whether a material is suitable for a given application or not can be ascertained on the basis of its fire behavior and the technical fire-safety requirements that are made in a given application case and that are stipulated in national and international standards or specifications.

Electrotechnical applications

Overload, improper utilization as well as manufacturing and assembly errors such as defective soldered points or loose connections all constitute crucial fire hazards in electrotechnical products. Therefore, the objective from the standpoint of technical fire-safety in the eventuality of a malfunction is to prevent the ignition of the component and the spread of the fire to the immediate surroundings, for instance, the furnishings or the building. In certain cases, the additional requirement exists that the housing must not catch fire if exposed to an external source of ignition.

The technical fire-safety requirements are described in special safety regulations for electrically operated devices and installations. The measures required there are meant to ensure that the safety objective is achieved.

This also includes measures of a structural nature such as the limitation of the temperatures in case of malfunction or the use of materials that have a low level of ignitability and flame spread.

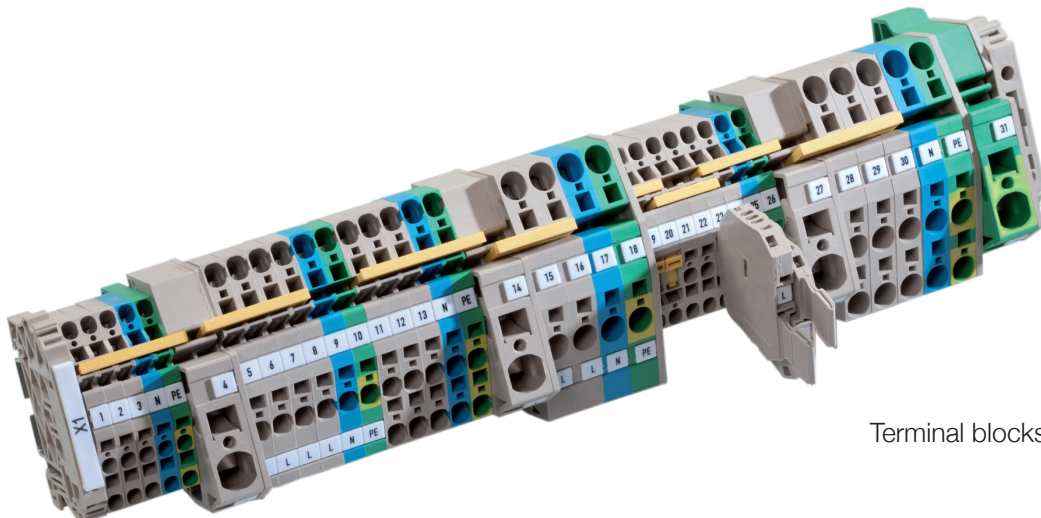

Terminal blocks

As a result of the globalization of the electrotechnical industry in recent years, the regulatory works issued by the International Electrotechnical Commission (**IEC**) and the American Underwriters Laboratories (**UL**) have acquired special significance worldwide. These regulatory works have evolved from national safety regulations such as those of the German Association for Electrical, Electronic and Information Technologies (**VDE**). This is also the source of many European standards (**EN Standards**) which have the status of national standards in the countries belonging to the **CENELEC** (Comité Européen de Normalisation Electrotechnique – European Committee for Electrotechnical Standardization). All of the countries of the European Community and Switzerland are members of CENELEC.

In accordance with the **WEEE Directive**⁹ (Waste Electrical and Electronic Equipment), manufacturers of new electrical and electronic equipment in Europe are obliged to take back and recover old electrical and electronic devices. Plastics containing brominated flame retardants have to be segregated, which can entail substantial additional costs. The take-back and dismantling obligation has been in force in Germany and Denmark since April 2006. In Austria, Belgium and Ireland, this obligation has existed for quite some time while in France, Spain, Italy and Great Britain, it will take effect at a later point in time.

The WEEE Directive is complemented by RoHS¹⁰ (Restriction of the use of certain hazardous substances in electrical and electronic equipment), which prohibits the use of certain environmentally hazardous substances. These include a number of brominated flame retardants. Such substances are not employed in the engineering plastics made by BASF.

Materials testing

A prerequisite for the use of plastics in electrotechnical applications is often that they have to comply with technical fire safety standards. The pertinent tests on the materials already have to be conducted during their development and pre-selection, for purposes of approval, and during quality control. The test standards specify the type of the source of ignition and their effect on the test specimens as well as the test setup and the dimensions of the test specimens for purposes of evaluating the ignitability and flame spread.

The **UL 94**¹¹ regulation of the Underwriters Laboratories is particularly important. Its contents have incorporated into **DIN IEC 60695-11-10**¹² and **-20**¹³ as well as into the Canadian **CSA C22.2**¹⁴: the ignition sources employed are test flames with an output of 50 watts or 500 watts to which the test specimens are briefly exposed twice. In this process, the burning time and the dripping of burning particles are evaluated by means of a cotton indicator placed under the test specimen.

Component - Plastics		E41871					
Guide Information							
BASF SE							
Performance Materials Europe, PMD/EX - H201, Ludwigshafen 67056 DE							
A3XZG7(f1)							
Polyamide 66 (PA66), glass reinforced "Ultramid", furnished as pellets							
Color	Min_Thk (mm)	Flame Class	HWI	HAI	RTI Elec	RTI Imp	RTI Str
BK	0.75	V-0	1	0	115	115	130
	1.5	V-0, 5VA	1	0	115	115	130
Comparative Tracking Index (CTI): 0				Inclined Plane Tracking (IPT) KV: 1			
Dielectric Strength (kV/mm): 19				Volume Resistivity (10 ^x ohm-cm): 11			
High-Voltage Arc Tracking Rate (HVTR): 1				Surface Resistivity (10 ^x ohms/square): -			
Dimensional Change (%): 0				High Volt, Low Current Arc Resis (D495): 6			
(f1) - Suitable for outdoor use with respect to exposure to Ultraviolet Light, Water Exposure and Immersion in accordance with UL 746C.							
ANSI/UL 94 small-scale test data does not pertain to building materials, furnishings and related contents. ANSI/UL 94 small-scale test data is intended solely for determining the flammability of plastic materials used in the components and parts of end-product devices and appliances, where the acceptability of the combination is determined by UL.							
Report Date: 1974-10-24							© 2021 UL LLC
Last Revised: 2013-03-04							

Fig.3: UL Yellow Card for Ultramid® A3XZG7

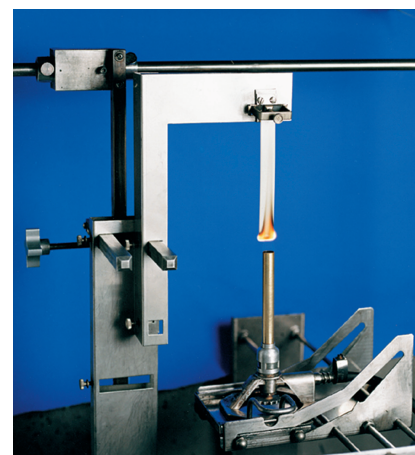

Fig.4: Vertical burning test according to **UL 94**

The classification for the specimen in the tested thickness is made in five stages, namely, 5V, V-0, V-1, V-2 (vertical burning test) and HB (horizontal burning test) (Fig.4, Table 3).

If self-colored products are to be manufactured, approval must be given for the color batch in combination with the base material. For its products, BASF offers solutions together with several batch suppliers.

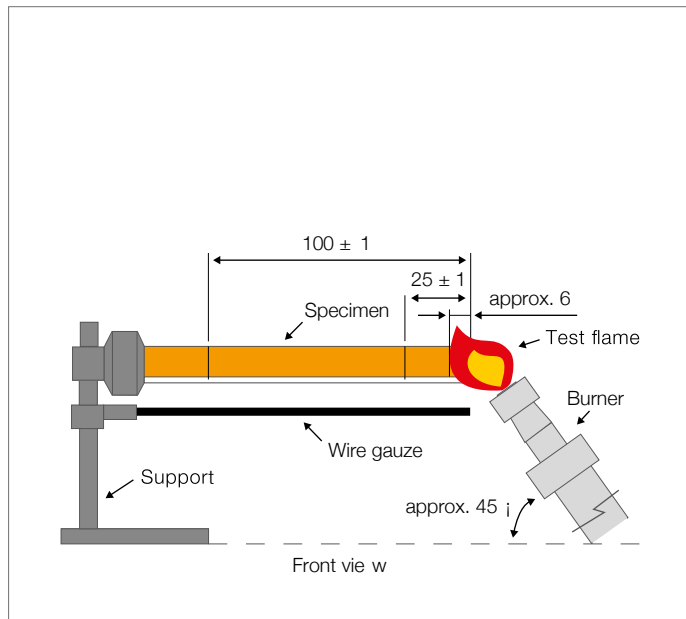

Fig.5: UL 94 HB (or DIN IEC 60695-11-10)

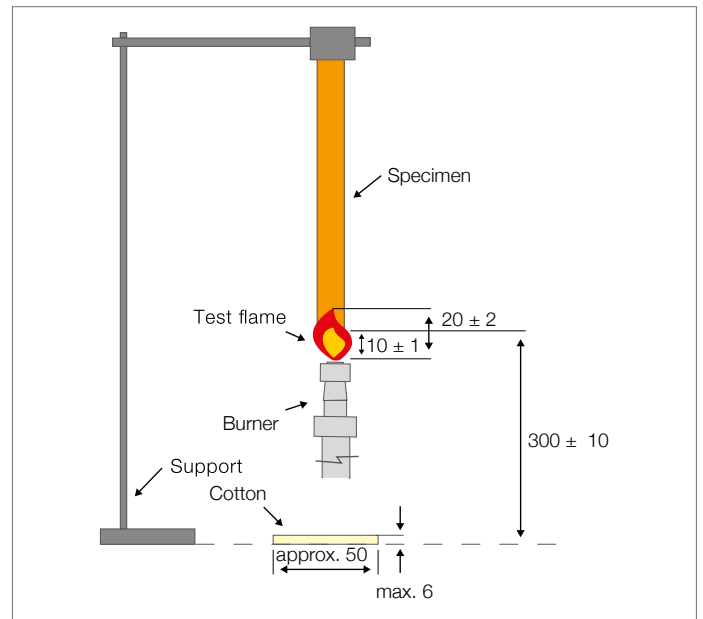

Fig.6: UL 94 V (or DIN IEC 60695-11-10)

Horizontal Burning Test (UL 94 HB), flame: 50W

Specimen thickness	Burning rate	Class
Flame extinguishes before 100-mm mark	–	HB
3-13 mm	< 40mm/min	HB
< 3mm	< 75mm/min	HB

Vertical Burning test (UL 94 V), flame: 50W

	V-0	V-1	V-2
Afterflame time for each Individual flaming	< 10s	< 30s	< 30s
Total afterflame time for any condition set (10 flamings)	< 50s	< 250s	< 250s
Afterflame plus afterglow time for each Individual specimen after 2 nd flaming	< 30s	< 60s	< 60s
Afterflame or afterglow of any specimen up to the holding clamp	no	no	no
Cotton indicator ignited by flaming drops	no	no	yes

Vertical Burning test (UL 94 5V), flame: 500W; only materials that fulfill at least V-1

	5VA	5VB
Afterflame plus afterglow time after 5th flaming, flame application for each specimen	≤ 60s	≤ 60s
Cotton indicator ignited by flaming drops	no	no
Complete Burning	no	no
Burn-through (hole) of any plaque specimen	no	yes

Tab. 3: Test criteria according to UL 94

The **UL 94 5V** test is conducted using a 125mm (500 W) test flame on materials that have already been rated as V-1 or better according to UL 94. First, five flame treatments are carried out on bars, each for five seconds with a five-second pause in between. If this first test step is passed successfully, plaque test specimens are tested in a second step using the same flame treatment (Fig.7). If holes are formed on the plaques, the test is passed with a 5VB classification; if no holes are formed, the material is given a 5VA classification.

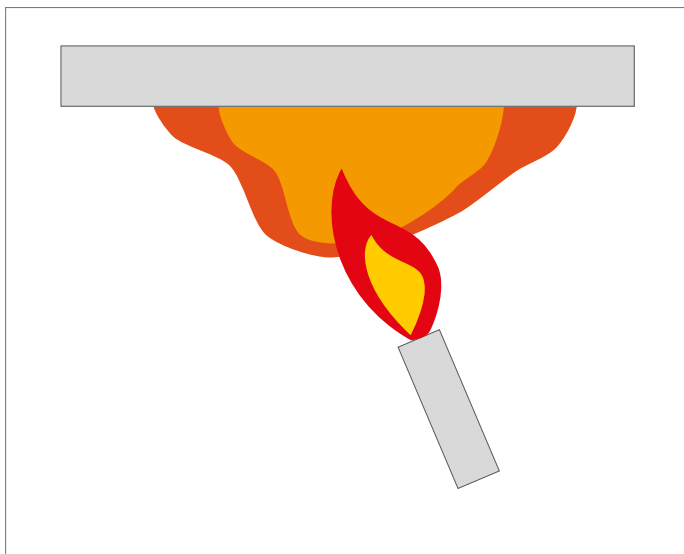

Fig.7: **UL 94 5V** (or **DIN IEC 60695-11-20**), application of a 125mm (500W) test flame to plaques 150-150mm²

In the so-called Hot Wire Ignition Test (**HWI**) according to **ASTM D 3874**¹⁶, an electrically heated resistance wire is wound around a horizontally arranged bar specimen. This simulates an ignition source resulting from overheating of the wires, especially in coils or transformers. The time when the specimen ignites (0 to 120 seconds) serves as the evaluation criterion for the classification into the ignitability categories PLC 0 to 5 (performance level categories) according to **UL 746 A, Section 31**¹⁷ (Fig. 8).

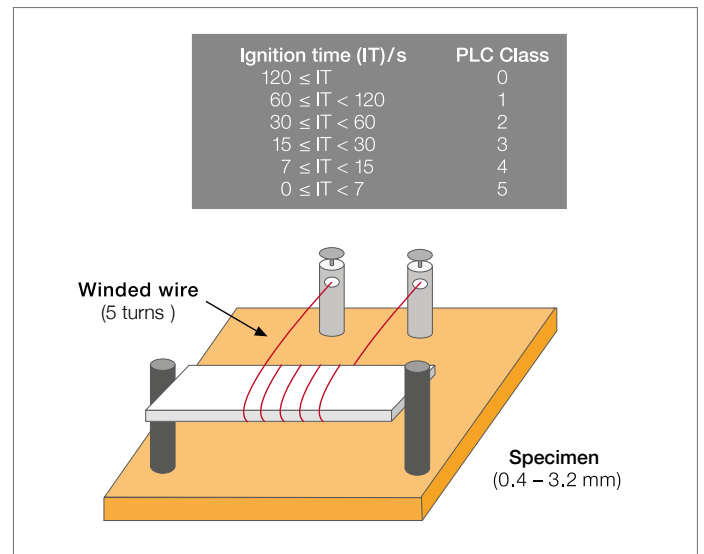

Fig.8: Hot Wire Ignition Test (HWI) according to **ASTM D 3874**¹⁶

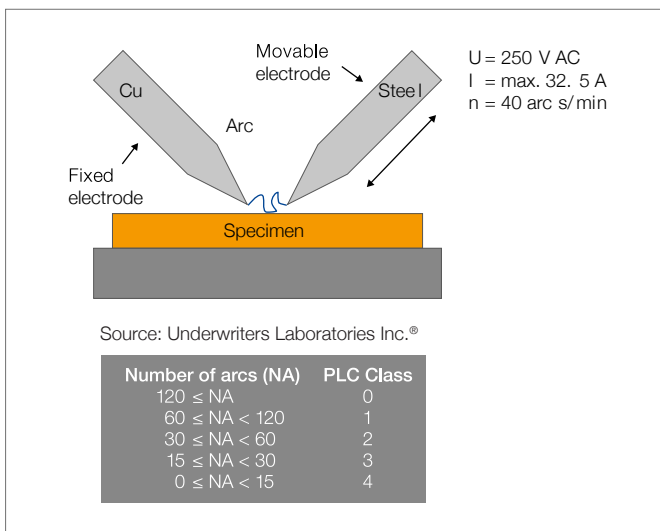

Fig.9: High Current Arc Ignition Test (HAI) according to **UL 746 A, Section 321**¹⁷



Charging inlet

In the so-called High Current Arc Ignition Test (HAI) according to **UL 746 A, Section 32¹⁷**, a test specimen is exposed to regularly recurring light arcs between two electrodes. With HAI, the number of light arcs up to ignition in PLC 0 to 4 is assessed (Fig.9).

Within the Underwriters Laboratories (UL) standards, a plastic used as an insulating material in electrical applications must pass a combination of various flammability and ignition tests (**UL 746 C**). The specific requirements or level to be achieved in the relevant type

tests are based both on the assessment of the existing appliance construction and on the application of the requirements (Table 4). The general rule is that the lower the flame retardant behavior of a plastic, the better its ignition performance must be.

The tendency towards tracking also depends on the properties of the material. This is characterized by the Comparative Tracking Index (CTI) which gives a relative rating of polymers (Table 5).

Example: For UL 94 V-0, the plastic must have an additional HWI above PLC 4 and an HAI above PLC 3

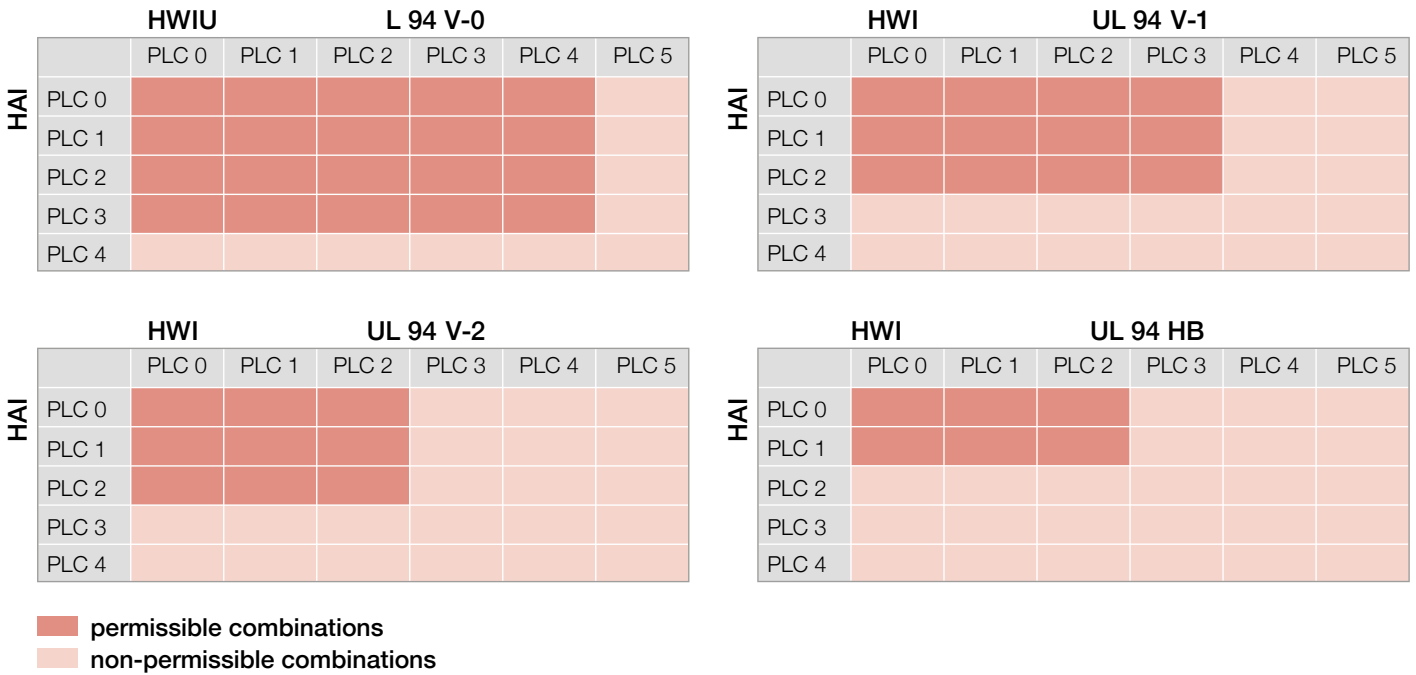

Tab. 4: Demands on plastics for insulation purposes in E&E applications (acc. to **UL 746 C**)

Material group	U_{test}/V	CTI failure criteria:
I	$600 \leq CTI$	<ul style="list-style-type: none"> ▪ Failure current IF $\geq 0.5A$ current for $\geq 2sec$ ▪ Flame formation of $\geq 2sec$
II	$400 \leq CTI \leq 600$	
IIIa	$175 \leq CTI \leq 400$	
IIIb	$100 \leq CTI \leq 175$	

Tab. 5: Material groups acc. **DIN EN 60664-1**

Tracking can be caused by contamination of the surface. The CTI test according to standard **IEC/DIN EN 60112** tries to simulate this by exposing the surface to a conductive test solution (Figs.10 and 11).

The sample is thermally decomposed by the light arcs, then traces of carbon black and ultimately tracks can be seen. This significantly reduces the insulating ability between two live contacts. In the CTI test, a test specimen is sprinkled successively between two live electrodes with 50 drops of an electrolytic solution. The CTI is the numerical value of the highest voltage at which no failure occurred on five samples after 50 applications of drops respectively.

The **DIN IEC 60695-2-10¹⁵ to -13** series of standards describes ignition tests employing a glow-wire. Here, overheated or incandescent metal parts are simulated. The wire loop heated up to the prescribed test temperature is pressed against the molded part that is being examined. It is then ascertained whether the test specimen ignites, whether the flames spread and whether flaming drips occur in a manner that promotes combustion. The glow-wire test can be carried out on standardized test plaques as well as on finished components (Fig.12).

Parts testing

Not only the properties of the material but also the geometrical shape determine the fire behavior of the final product. This is why it is often necessary to also carry out tests on the finished parts.

This is taken into consideration in the completely revised standard on the safety of electric household appliances, **IEC/DIN EN 60335-1¹⁸**. Section 30 provides a general description of the requirements made in terms of heat and fire resistance (Fig.14).

The highest requirements apply to household appliances that operate unattended and through which high currents flow (bigger than 0.2 A). These include switches and connections in washing machines and dishwashers, refrigerators and ovens as well as electric motors in central vacuum systems or exhaust hoods. Plastics used in these devices fundamentally have to pass an ignitability test for the material (GWFI) according to **DIN IEC 60695- 2-12¹⁹** at 850 ° C [1562 ° F] (extinction of the flame within the testing and observation time of 60 seconds).

In addition, requirements call for a glow-wire test on standardized test plaques according to **DIN IEC 60695-2-13²⁰** (GWIT at 775° C [1427° F], maximum flame duration of 5 seconds). If such a value is not attained, then as an alternative, the finished component can undergo a test according to **DIN IEC 60695-2-11²¹** (GWEPT, Glow Wire End Product Test, at 750° C [1382° F], but by stricter regulation of the maximum flame duration of 2 seconds according to **IEC/DIN EN 60335-1¹⁸**) or one of three other possible tests on the surrounding components. Figure 14 shows the maximum necessary requirements.

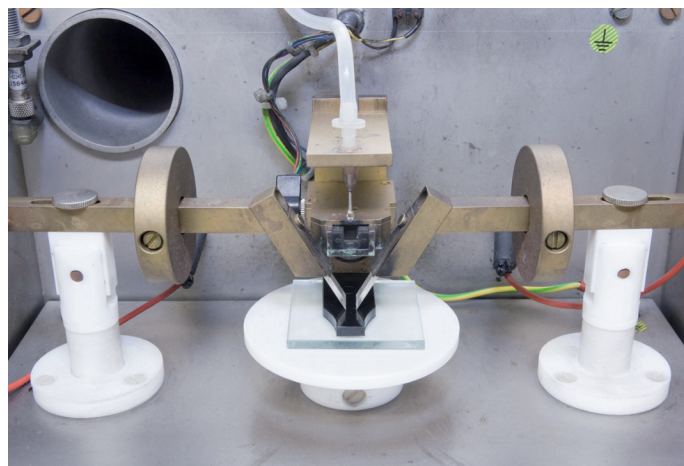

Fig.10: CTI, actual test set-up

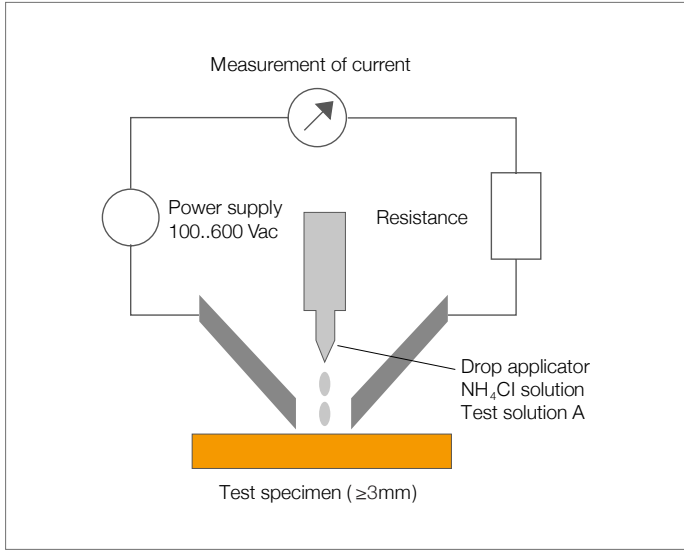

Fig.11: CTI, measuring principle

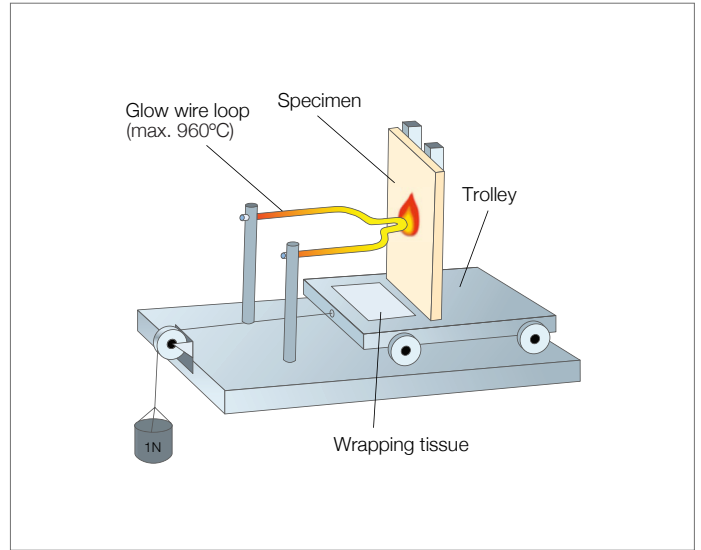

Fig.12: Glow-wire test according to **DIN IEC 60695-2-10¹⁵**

Tests involving the effect of flames are also important. Ignition flames can affect an electrotechnical product from the inside as well as from the outside. Especially cables and lines can be exposed to the external effects of flames when a fire breaks out.



Several product standards require the needle-flame test according to **IEC/DIN EN 60695-11-5**²² or **UL 746 C**²³. Here, a 12mm long test flame is held for a certain period of time (intensity levels) at the edges or surfaces of molded parts. The evaluation examines the after flame time following exposure to the flame and checks whether a cotton indicator positioned underneath was ignited by dripping material (Fig.15). Safety requirements for the fire protection of audio/video equipment and for information and communication technology are defined in the standards **IEC/DIN EN 60065**²⁴ and **IEC/DIN EN 60950-1**²⁵.

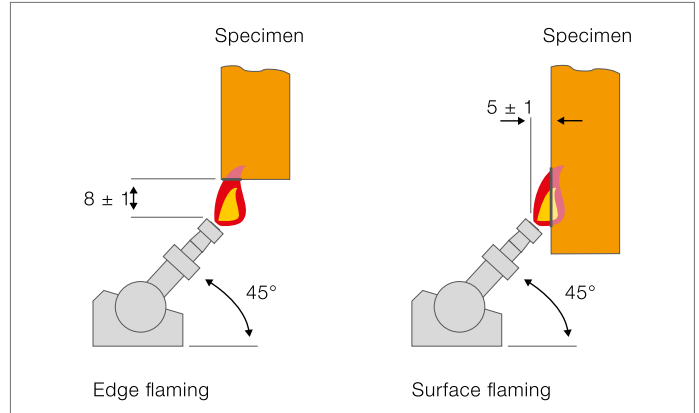

Fig.15: needle-flame test IEC/DIN EN 60695-11-5

Since 2014, the so-called Hazard Based Standard **IEC/DIN EN 62368-1**²⁶ has also been available in parallel. This will replace **IEC/DIN EN 60065**²⁴ and **IEC/DIN EN 60950-1**²⁵ in the medium term. There are regional differences, some of which are significant, in the specific requirements. For example, for what are known as fire protection housings, materials that conform to at least class V-1 according to **IEC/DIN EN 60695-11-10**¹² are required. Another persistent discussion, in Europe in particular, relates to the introduction of requirements for external ignition sources (“Candle Flame Ignition Test” according to **IEC/ TS 62441**²⁷).

Fire-protected products in electrotechnical applications

BASF’s engineering plastics with flame-retardant properties are employed, for example, for plugs and plug connectors, mountings and terminals, relays and low-voltage switching devices (for instance, protective motor switches and circuit breakers).

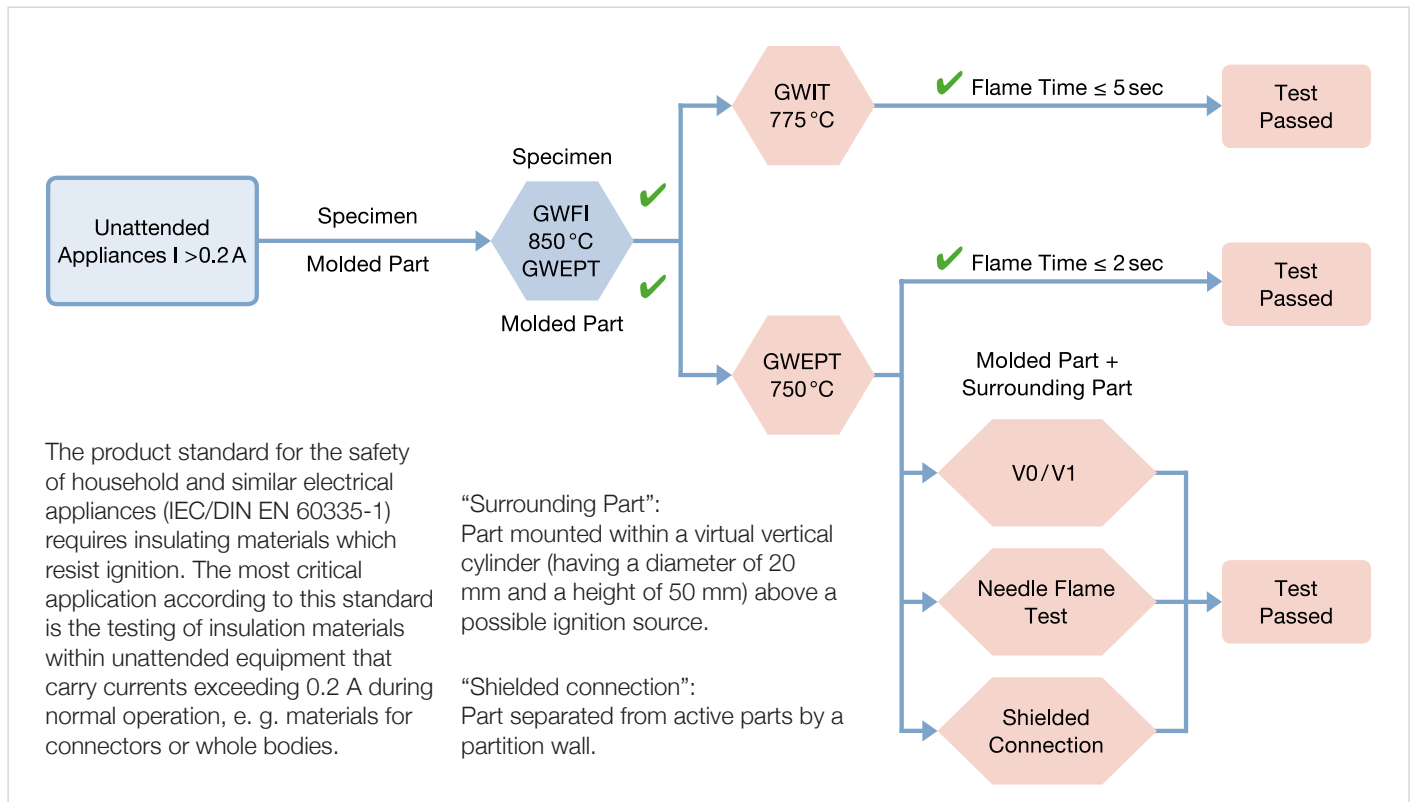

Fig. 14: Selection and sequence of tests for resistance to heat and fire according to IEC/DIN EN 60335-1, Section 30.2.3.

Literature

- ¹ DIN EN ISO/IEC 17025 Allgemeine Anforderungen an die Kompetenz von Prüf- und Kalibrierlaboratorien
- ² Seekamp, H. Das Brandgeschehen und die Systematik der Prüfmethode, Materialprüfung 5 (1963) 2, Seiten 45-49
- ³ Becker, W. Brandgefahr und Prüfung des Brandverhaltens von Kunststoffen, Kunstst. Plast. (Solothurn, Schweiz) 22 (1975) 6, Seiten 19-25
- ⁴ Troitzsch, J. Plastics Flammability Handbook – Principles, Regulations, Testing, and Approval, 3rd edition, München, Wien, Carl Hanser Verlag (2004)
- ⁵ DIN 54836 Prüfung von brennbaren Werkstoffen; Bestimmung der Entzündungstemperatur
- ⁶ DIN 51900-1 Bestimmung des Brennwertes mit dem Bomben-Kalorimeter und Berechnung des Heizwertes, Teil 1: Allgemeine Angaben, Grundgeräte, Grundverfahren
- ⁷ NIOSH (National Institute for Occupational Safety and Health) pocket guide to chemical hazards
- ⁸ Pohl, K. D. et al. Analytik kontaminierter Löschwässer, Wasser, Luft und Boden, 9 (1994), Seiten 38-43
- ⁹ Richtlinie 2002/96/EG (Waste Electrical and Electronic Equipment WEEE) über Elektro- und Elektronik-Altgeräte
- ¹⁰ Richtlinie 2002/95/EG (Restriction of the use of certain hazardous substances in electrical and electronic equipment RoHS) Richtlinie zur Beschränkung der Verwendung bestimmter gefährlicher Stoffe in Elektro- und Elektronikgeräten
- ¹¹ UL 94 Tests for flammability of plastic materials for parts in devices and appliances
- ¹² IEC/DIN EN 60695-11-10 Prüfungen zur Beurteilung der Brandgefahr, Teil 11-10: Prüfverfahren mit 50-W-Prüfflamme horizontal und vertikal
- ¹³ IEC/DIN EN 60695-11-20 Prüfungen zur Beurteilung der Brandgefahr, Teil 11-20: Prüfverfahren mit einer 500-W-Prüfflamme
- ¹⁴ CSA C 22.2, No. 0.17-92 Evaluation of Properties of Polymeric Materials – General Requirements; Part 4: Flame Test Procedure
- ¹⁵ DIN IEC 60695-2-10 Prüfungen zur Beurteilung der Brandgefahr; Teil 2-10: Prüfungen mit dem Glühdraht, Glühdrahtprüfeinrichtungen und allgemeines Prüfverfahren
- ¹⁶ ASTM D 3874-04 Test Method for Ignition of Materials by Hot Wire Sources
- ¹⁷ UL 746 A, Polymeric Materials – Short Term property Evaluations
- ¹⁸ IEC/DIN EN 60335-1 Sicherheit elektrischer Geräte für den Hausgebrauch und ähnliche Zwecke – Teil 1: Allgemeine Anforderungen
- ¹⁹ DIN IEC 60695-2-12 Prüfungen zur Beurteilung der Brandgefahr; Teil 2-12: Prüfung mit dem Glühdraht zur Entflammbarkeit von Werkstoffen (GWFI)
- ²⁰ DIN IEC 60695-2-13 Prüfungen zur Beurteilung der Brandgefahr; Teil 2-13: Prüfungen mit dem Glühdraht zur Entzündbarkeit von Werkstoffen (GWIT)
- ²¹ DIN IEC 60695-2-11 Prüfungen zur Beurteilung der Brandgefahr; Teil 2-11: Prüfung mit dem Glühdraht zur Entflammbarkeit von Enderzeugnissen (GWEPT)
- ²² IEC/DIN EN 60695-11-5 Prüfungen zur Beurteilung der Brandgefahr; Teil 11-5: Prüfverfahren mit der Nadelflamme
- ²³ UL 746 C Polymeric Materials, Use in Electrical Equipment Evaluations
- ²⁴ IEC/DIN EN 60065 Audio-, Video- und ähnliche elektronische Geräte; Sicherheitsanforderungen
- ²⁵ IEC/DIN EN 60950-1 Information technology equipment – Safety – Part 1: General requirements
- ²⁶ IEC/DIN EN 62368-1 Audio/video, information and communication technology equipment – Part 1: Safety requirements
- ²⁷ IEC/TS 62441 Safeguards against accidentally caused candle flame ignition for audio/video, communication and information technology equipment

BASF Data Slider

STANDARDS AND TEST METHODS FOR THE E/E INDUSTRY

Burning behavior acc. to UL 94V

Flammability

Class

Burning time for each individual specimen

Total burning time (10 flame applications)

Dripping of burning specimens (ignition of cotton indicator)

HAI acc. to UL 746 A

Ignition by an electric arc

Class / PLC

Number of arcs until ignition

Fire / ignition requirements acc. to UL 746 C

Class / PLC	HWI					
	0	1	2	3	4	5
0	HB					
1	HB					
2	V-2			V-1		
3					V-0	
4						

According to this Underwriters Laboratories (UL) standard, a plastic used as an insulating material in electrical applications must comply with a combination of three different test ratings. Example: class V-0 requires an additional HAI ≤ PLC 3 and HWI ≤ PLC 4

GWIT, GWFI acc. to IEC 60605-2-1X

Ignition by a hot wire

Temperature at which a sample ignites or extinguishes, max. 960 °C

HWI acc. to UL 746 A

Ignition by a hot wire

Class / PLC

Time until ignition

CTI acc. to IEC 60112 / UL746A

Electrical tracking resistance

CTI is the numerical value of the highest voltage without failure on five specimens after 50 drops of test solution

UL PLC	Voltage [V]	Isolation class
0	500	I
1	400 – 500	II
2	250 – 300	IIIa
3	175 – 249	IIIb
4	100 – 174	
5	<100	

Minimum distance to avoid electrical tracking at a given operational voltage acc. to IEC 60664-1

Degree of pollution	Isolation class I			Isolation class II			Isolation class III		
	400V	630V	800V	400V	630V	800V	400V	630V	800V
1 none or non-conductive	mm	mm	mm	mm	mm	mm	mm	mm	mm
2 non-conductive, sometimes conductivity due to dewing	mm	mm	mm	mm	mm	mm	mm	mm	mm
3 conductive contamination	mm	mm	mm	mm	mm	mm	mm	mm	mm

Subject to changes and errors. Status Oktober 2020.

Further information can be found on the internet at: www.emobility-plastics.basf.com

With the BASF Data Slider you get useful information about our products, the most important key facts, material suggestions for selected eMobility applications as well as an overview of standards and test methods.

[Contact us to order your Data Slider](#)

Note

The data contained in this publication are based on our current knowledge and experience. In view of the many factors that may affect processing and application of our product, these data do not relieve processors from carrying out own investigations and tests; neither do these data imply any guarantee of certain properties, nor the suitability of the product for a specific purpose. Any descriptions, drawings, photographs, data, proportions, weights, etc., given herein may change without prior information and do not constitute the agreed contractual quality of the product. It is the responsibility of the recipient of our products to ensure that any proprietary rights and existing laws and legislation are observed. (December 2021)

[Visit our eMobility homepage](#) to get an overview on BASF's product portfolio or [contact our experts](#)